

Ancient Monuments Laboratory  
Report 54/1999

TREE RING ANALYSIS OF TIMBERS  
FROM PASTON GREAT BARN,  
NORFOLK

I Tyers

Opinions expressed in AML reports are those of the author and are not necessarily those of English Heritage (Historic Buildings and Monuments Commission for England).

TREE RING ANALYSIS OF TIMBERS FROM  
PASTON GREAT BARN, NORFOLK

I Tyers

Summary

Paston Great Barn is a huge 20 bay stone-walled barn classified as both a Scheduled Ancient Monument, and a Site of Special Scientific Interest. The roof trusses are alternating tie-beam and hammer-beam types with arch-braces and wall posts rising from corbels on the walls. Queen struts rise from the tie-beams and hammer-beams to the lower of the two collars. The two trusses opposite the full height double doors on the east side are of a third type with stub tie-beams and arch-bracing from the walls to the lower collar. It is undergoing an extensive grant-aided repair programme, aimed at preserving the building so that it may continue to house its colony of rare bats. The tree-ring analysis reported here was funded by English Heritage to inform repair decisions. The results confirm the majority of the extant timber structure is derived from the documented construction by Sir William Paston in 1581. It had been thought possible some of the structure was from either later undocumented repairs or from re-used timbers obtained from several nearby demolished monastic properties also owned by the Paston family. The resultant chronology is of interest in that the site is both geographically remote from the other contemporaneous tree ring chronologies and likely to be of coastal origin. The poor state of preservation of the timbers makes the recovery of sapwood on the samples and the identification of the heartwood/sapwood boundaries especially difficult in this building. The surviving sapwood has been so extensively attacked by deathwatch beetle that there was no opportunity to obtain bark-edge from the sampled material.

Author's address :-

I Tyers  
SHEFFIELD DENDROCHRONOLOGY LABORATORY  
Archaeology Research School  
University of Sheffield West Ct 2 Mappin St  
Sheffield  
S1 4DT

## TREE-RING ANALYSIS OF TIMBERS FROM THE PASTON GREAT BARN, NORFOLK

### Introduction

This document is a technical archive report on the tree-ring analysis of oak timbers from Paston Great Barn, Norfolk (NGR TG 321 345). It is beyond the dendrochronological brief to describe the building in detail or to undertake the production of detailed drawings. As part of a multifaceted and multidisciplinary study of the building, elements of this report may be combined with detailed descriptions, drawings, and other technical reports at some point in the future to form either a comprehensive publication or an archive deposition on the building. The conclusions may therefore have to be modified in the light of subsequent work.

The Great Barn is a 50m long 20-bay stone-walled building located about 1km inland from the north-east coast of Norfolk (Fig 1). The barn is aligned approximately north-south, and it has a series of east-west aligned ranges which are mostly later in date than the main structure (Fig 2). Pevsner and Wilson (1997, 638) suggest the building was primarily designed for show and it and its sister structure at Waxham, possibly built earlier and on an even greater scale, appears to be the product of rivalry between the Paston and Wodehouse families. The building is grade II\* listed and on the Buildings at Risk register (English Heritage 1998a), whilst also being a Scheduled Ancient Monument (Norfolk 168), and a Site of Special Scientific Interest (SSSI). At the time of sampling the building was undergoing English Heritage grant-aided remedial works to both the timber roof and the thatching in the northern half of the barn. These repairs were timetabled to cause as little disruption as possible to the breeding colony of Barbastelle bats. The roof consists of twenty one oak trusses, of three types (Fig 3a-c). There is a clearly visible surviving historic truss-numbering scheme that runs from I through XXI north to south. This numbering scheme has been used in this report (Table I). Additional historic carpentry elements are present in the two huge eastern door frames, and in the sills and lintels of the windows and smaller west side doors. Several elements are obviously later insertions, including some timbers from documented twentieth-century repairs.

A tree-ring dating programme of the timbers was requested by Ian Harper from English Heritage to inform the proposed grant-aided repairs and alterations to this important building, the request covered the main structure and the western range.

### Methodology

The general methodology and working practises used at the Sheffield Dendrochronology Laboratory are described in English Heritage (1998b). The methodology used for this building was as follows.

Following receipt of the dendrochronology request a series of phone calls were made to Tony Mitchell-Jones, English Nature's Vertebrate Specialist, to discuss the issue of the bat colony. Subsequently, a meeting in November 1998 was arranged with Philip Walker, English Heritage Inspector of Ancient Monuments, Malcolm Crowder, Secretary of the North Norfolk Historic Buildings Trust, Anthony Rossi,

Historic Buildings Architect, John Goldsmith, Norfolk Bat Group, Stephen Heywood, Norfolk County Council, several members of both the English Heritage East Anglia Team, and the English Nature Norfolk Team and myself at the property to discuss both the impact of the sampling on the bat population resident during the summer months, and any constraints put on the sampling by the terms of the Scheduled Monument Consent for the remedial works. An agreement was reached at that meeting that the sampling could proceed as long as it was undertaken during the winter period and avoided certain timbers acting as maternity roosts. A brief survey was made of the area of the roof scaffolded at that stage, bays 1-4, to identify whether the building contained oak timbers suitable for analysis. Those with more than 50 annual rings and some survival of the original sapwood and bark-edge were sought. The main building was assessed as being well endowed with suitable material for sampling, the western side range was assessed as unsuitable for sampling as none of the timbers contained sufficient rings for reliable dendrochronological analysis. The actual sampling was undertaken during two additional visits, an initial 2 day sampling trip in December 1998 during which roof timbers in the bays 1-4 area were sampled, as well as corbels the entire length of the barn, and some door lintels and posts. A subsequent visit in early April 1999 was arranged when the scaffold was extended to bay 12, and the remedial works had identified and removed sections of some timbers throughout bays 1-12. The dendrochronological sampling programme attempted to obtain cores or slices from as broad a range of timbers, in terms of structural element types, scantling sizes, and carpentry features, as was possible within the terms of the request and the special factors pertaining to the bat population.

The most promising timbers were sampled using a 15mm diameter corer attached to an electric drill. The cores were taken as closely as possible along the radius of the timbers so that the maximum number of rings could be obtained for subsequent analysis. The core holes were left open initially but were subsequently filled by the carpentry team. The removed sections of repaired timbers were assessed initially and then cut into approximate length for me by the carpentry team. These samples were subsequently cut into final form at the laboratory. The ring sequences in both the cores and slices were revealed by sanding.

The complete sequences of growth rings in the samples that were selected for dating purposes were measured to an accuracy of 0.01mm using a micro-computer based travelling stage (Tyers 1997a). The ring sequences were plotted onto semi-log graph paper to enable visual comparisons to be made between sequences. In addition cross-correlation algorithms (Baillie and Pilcher 1973) were employed to search for positions where the ring sequences were highly correlated. These positions were checked visually using the graphs and, where these were satisfactory, new mean sequences were constructed from the synchronised sequences. The *t*-values reported below are derived from the original CROS algorithm (Baillie and Pilcher 1973). A *t*-value of 3.5 or over is usually indicative of a good match, although this is with the proviso that high *t*-values at the same relative or absolute position must be obtained from a range of independent sequences, and that these positions are supported by satisfactory visual matching.

All the measured sequences from this assemblage were compared with each other and any found to cross-match were combined to form a site master curve. These, and any remaining unmatched ring sequences were tested against a range of reference chronologies, using the same matching criteria: high *t*-values, replicated values against a range of chronologies at the same position, and satisfactory visual matching. Where such positions are found these provide calendar dates for the ring-sequence.

The tree-ring dates produced by this process initially only date the rings present in the timber. The interpretation of these dates relies upon the nature of the final rings in the sequence. If the sample ends in the heartwood of the original tree, a *terminus post quem* (*tpq*) for the felling of the tree is indicated by the date of the last ring plus the addition of the minimum expected number of sapwood rings which are missing. This *tpq* may be many decades prior to the real felling date. Where some of the outer sapwood or the heartwood/sapwood boundary survives on the sample, a felling date range can be calculated using the maximum and minimum number of sapwood rings likely to have been present. The sapwood estimates applied throughout this report are a minimum of 10 and maximum of 46 annual rings, where these figures indicate the 95% confidence limits of the range. These figures are applicable to oaks from England and Wales. Alternatively, if bark-edge survives, then a felling date can be directly utilised from the date of the last surviving ring. The dates obtained by the technique do not by themselves necessarily indicate the date of the structure from which they are derived. It is necessary to incorporate other specialist evidence concerning the re-use of timbers and the repairs of structures before the dendrochronological dates given here can be reliably interpreted as reflecting the construction date of phases within the structure.

A further important element of the tree-ring analysis of buildings and archaeological assemblages is the identification of 'same tree' groups within the sampled material. Inspection of timbers, both in buildings and archaeological sites, often suggests that the patterns of knots or branching in timbers are so similar that they appear to be derived from a single tree. Tree-ring analysis is often used to support these suggestions. The identification of 'same tree' groups is based on a combination of high levels of matching between samples, extremely similar longer-term growth trends, and individual anatomical anomalies within the timbers. High *t*-values are not by themselves necessarily indicative of two series being derived from a single tree. Conversely low *t*-values do not necessarily exclude the possibility. It is the balance of a range of information that provides the evidence.

### **Results**

Access to the roof timbers in this building was difficult in the areas without a scaffold. The floor-to-tie-beam height is in the order of six metres, with the collars a further two metres up. The floor is mostly earthen and scattered with modern junk. The extreme height and lack of good stable footings combine to limit access to the higher structural elements beyond bay 12. Ladders provided access to some of the corbels along the sides of the building, since these are only around 3.5 metres above the floor. However apart from these no sampling has been undertaken on trusses 13 to 21 (see discussion).

A total of 42 timbers were selected as most suitable for sampling (Table 1; Figs 4a-b, 5a-j). The samples were numbered **1-42** inclusive.

Six of the 42 samples when examined in the laboratory were rejected: samples **13, 14, 17, 23, 30, and 34** had all fragmented badly during sampling and were of no further use. The 36 remaining samples were measured and then compared with each other. Twenty two sequences were found that matched together to form an internally consistent group (Table 2). A 213-year site mean chronology was calculated, named PASTON. The site mean was then compared with dated reference chronologies from throughout the British Isles and northern Europe. Table 3 shows the correlation of the mean sequences at the dating position identified for the sequence, AD 1356 - 1568 inclusive. Table 4 lists the site mean chronology.

The remaining measured samples did not match either the rest of the material from Paston nor dated reference chronologies.

### **Interpretation**

The 213-year chronology PASTON is dated AD 1356 to 1568 inclusive. It was created from 22 timbers. None of the dated samples were complete to bark-edge, but seventeen dated samples retain either some sapwood or are complete to the heartwood/sapwood boundary (Table 1; Fig 6). Inspection of the bar diagram (Fig 6) suggests they are derived from a single group. Assuming this is the case a combined felling date range can be calculated by taking the latest of the *terminus post quem* dates or start dates of the calculated felling date ranges and the earliest of the end dates of the calculated felling date ranges. This simple calculation makes no allowance for the probability distribution within each of the calculated 95% probability felling date ranges. This method thus yields a conservative range compared to strictly correct statistical calculations. Such estimated felling date ranges only provide a reliable date range for dated assemblages if they are the product of a single felling event. In the absence of bark-edge this assumption cannot be proven for any particular building. For Paston the combined felling range for all the dated material is calculated by the method outlined above to fall between AD 1574 and 1585. There is no obvious progression in the dates of the heartwood/sapwood boundaries along the length of the building.

### **Discussion**

The building has a date stone over the south-west door assigning its construction to Sir W Paston in 1581. The interpretation of the results clearly indicates that the dated timbers are contemporary with the date stone. However, the failure to obtain complete sapwood from any of the sampled timbers means it is impossible to compare the precise year, or years, of felling with the date given on the date stone. The building has been, and continues at least up to the time of this refurbishment, to be severely attacked by death-watch beetle and this has resulted in the sapwood being too friable to be successfully cored by current techniques.

The results eliminate the possibility that the timbers used for the construction of the barn were primarily derived from nearby suppressed monastic buildings. Four of the dated timbers have last ring dates that

*could* allow them to have been felled in the monastic period. However, none of these is obviously re-used, and all are likely to be simply heavily converted timbers that have lost more than the normal numbers of the original outermost rings. There are no obvious differences between these four timbers and the rest of the material in terms of tree-ring correlation.

Considering the relatively large number of samples the paucity of same-tree matches is something of a surprise. The tie-beams are *c* 9m in length and there is thus unlikely to be anything else derived from the same trees as these. However this is not the case with the hammer-beams, corbels, braces etc, which could have been derived from multiple offcuts of the same set of timbers. Such a supposition is not supported by the sampling currently obtained. A single pair of corbels are identified by the similarity of their tree-ring sequences as being derived from the same tree, these are samples **16** (truss 2: west corbel) and **24** (truss 8: west corbel). The north and south door posts of the great north-east entrance (samples **19** and **20**) are also identified by the tree-ring sequences as being derived from the same tree; this was identified on site as probably the case before sampling. Pevsner and Wilson (1997, 638) suggested the hammer-beams were created by sawing out a central section of alternate tie-beams after construction, this suggestion is not supported in the three trusses where samples were obtained from both hammer-beams (trusses 2, 4, and 8). In two cases only one hammer-beam has dated, whilst in the third instance both have dated but there is little similarity beyond that normally exhibited by contemporaneous samples from different trees.

Paston Barn is located in one of the most remote areas for tree-ring data in England. The nearest available data sets being an early fifteenth-century set from Dragon Hall in Norwich (Boswijk and Tyers 1998) and a late seventeenth-century set from Felbrigg Hall (Tyers 1998). The nearest broadly contemporary data is from King's Lynn on the other side of the county of Norfolk (Tyers 1999a). Prior to the sampling it was expected that the data would be difficult to date absolutely with available reference sequences. In the event the data has some unexpectedly good matching across the western Midlands counties of England, and also some of the data from London, Kent, Essex, and rather more surprising perhaps Yorkshire, whilst also matching eastwards into Holland and Germany. At this stage in the construction of East Anglian reference data sets it is not clear if this is 'normal' or if there is something unusual about the Paston chronology. Thus although its length and replication make it a useful addition to current data sets, it is not yet clear whether it is a useful addition to the Norfolk/Suffolk data sets or something of an aberration. A useful test could be the nearby Waxham Great Barn, an even larger barn of the same type built at around the same time by the rival Wodehouse family, which has also recently been repaired.

At the outset of the project it was hoped sampling would continue down the length of the barn as the refurbishment program proceeded, this would have involved further sampling being undertaken in the winter of 1999/2000. The failure to be able to address the micro-chronological details of variation in felling date through the barn due to the poor condition of the sapwood and the production of a dated well-replicated tree-ring chronology has resulted in the decision to cease sampling at this point. It is intended that the offcuts removed in the next refurbishment season will be examined and some samples obtained,

but the generally poorer condition of the southern trusses means it is unlikely that any of these will materially contribute to the understanding of the building

### **Conclusion**

The dendrochronological analysis of timbers from Paston Great Barn indicates the timbers are from the period of the well-documented original construction date of the barn. No timbers were identified that were definitely attributable to demolished pre-dissolution monastic properties, and none of the dated timbers was derived from any later refurbishment. The chronology produced may help date other less suitable buildings in the area but this is not yet proven.

### **Acknowledgements**

The sampling and analysis programme was funded by English Heritage. My thanks to Anthony Rossi, Stephen Heywood, Malcolm Crowder, John Goldsmith, and Tony Mitchell-Jones, and others, for their help and assistance with the management of this complex project. Anthony Rossi kindly supplied copies of the figures used as the basis for Figs 2-6. Ray and other staff from A.J. Cooper and Company helped in various ways during the second sampling trip. Cathy Groves (Sheffield University, Dendrochronology Laboratory) and Alex Bayliss (English Heritage, Ancient Monuments Laboratory) provided useful discussion of the practicalities and implications.

### **References**

- Baillie, M G L, and Pilcher, J R, 1973 A simple crossdating program for tree-ring research, *Tree Ring Bulletin*, **33**, 7-14
- Boswijk, G, 1998 *Tree-ring analysis of Thorpe Prebend House, High Saint Agnesgate, Ripon, North Yorkshire*, Anc Mon Lab Rep, **2/98**
- Boswijk, G, and Tyers, I, 1998 *Tree-ring analysis of oak timbers from Dragon Hall, King Street, Norwich*, ARCUS rep, **365**
- English Heritage, 1998a *English Heritage Register of Buildings at Risk 1998*, London
- English Heritage, 1998b *Guidelines on producing and interpreting dendrochronological dates*, London
- Hollstein, E, 1980 *Mitteleuropäische Eichenchronologie*, Mainz
- Howard R E, Laxton, R R, and Litton, C D, 1997 *Tree-ring analysis of timbers from Astley Castle, Astley, Warwickshire*, Anc Mon Lab Rep, **83/97**
- Laxton, R R, and Litton, C D, 1988 *An East Midlands master tree-ring chronology and its use for dating vernacular buildings*, University of Nottingham, Dept of Classical and Archaeological Studies, Monograph Series, **III**
- Laxton, R R, and Litton, C D, 1989 Construction of a Kent master chronological sequence for oak, 1158-1540 AD, *Med Archaeol*, **33**, 90-98
- Pevsner, N, and Wilson, B, 1997, *The buildings of England. Norfolk I: Norwich and North East*, 2<sup>nd</sup> edn, Harmondsworth



Tyers, I, 1997a *Dendro for Windows program guide*, ARCUS Rep, **340**

Tyers, I, 1997b *Dendrochronological analysis of timbers from Sinai Park, Staffordshire*, Anc Mon Lab Rep, **80/97**

Tyers, I, 1998 *Tree-Ring analysis of the roof of the Samwell wing at Felbrigg Hall, Norfolk*, Anc Mon Lab Rep, **65/98**

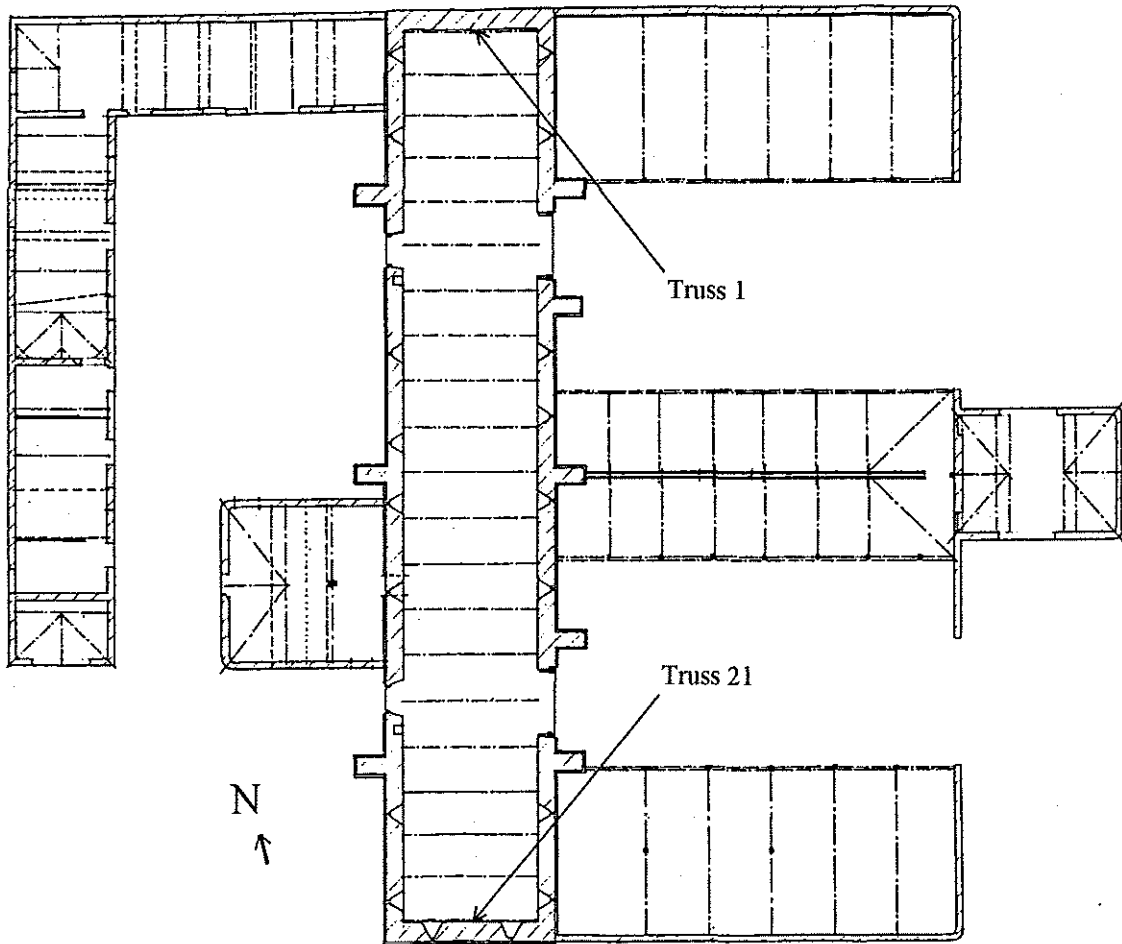
Tyers, I, 1999a *Tree-ring analysis of timbers from Marriot's Warehouse, King's Lynn, Norfolk*, Anc Mon Lab Rep, **11/99**

Tyers, I, 1999b *Tree-ring analysis of timbers from five buildings in Essex*, ARCUS Rep, **345**

Tyers, I, 1999c *Dendrochronological analysis of timbers from Black Ladies, near Brewood, Staffordshire*, ARCUS Rep, **484**

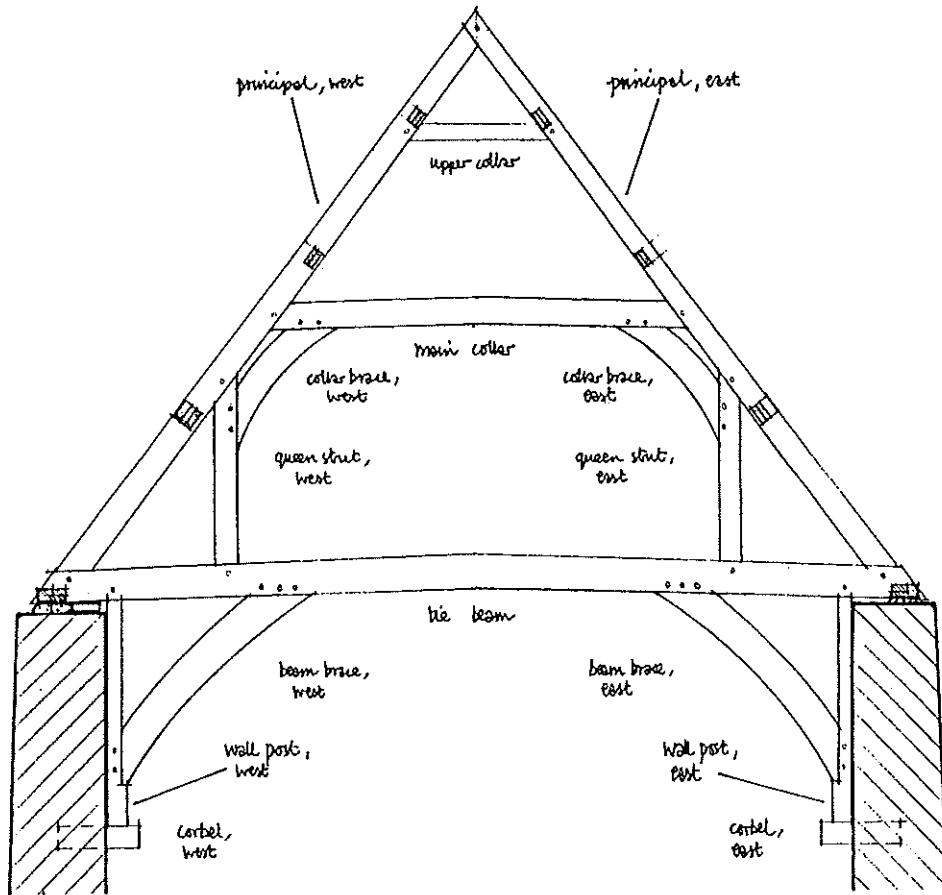


**Figure 2** Sketch plan of the barn and its side ranges, based on a drawing kindly supplied by Anthony Rossi

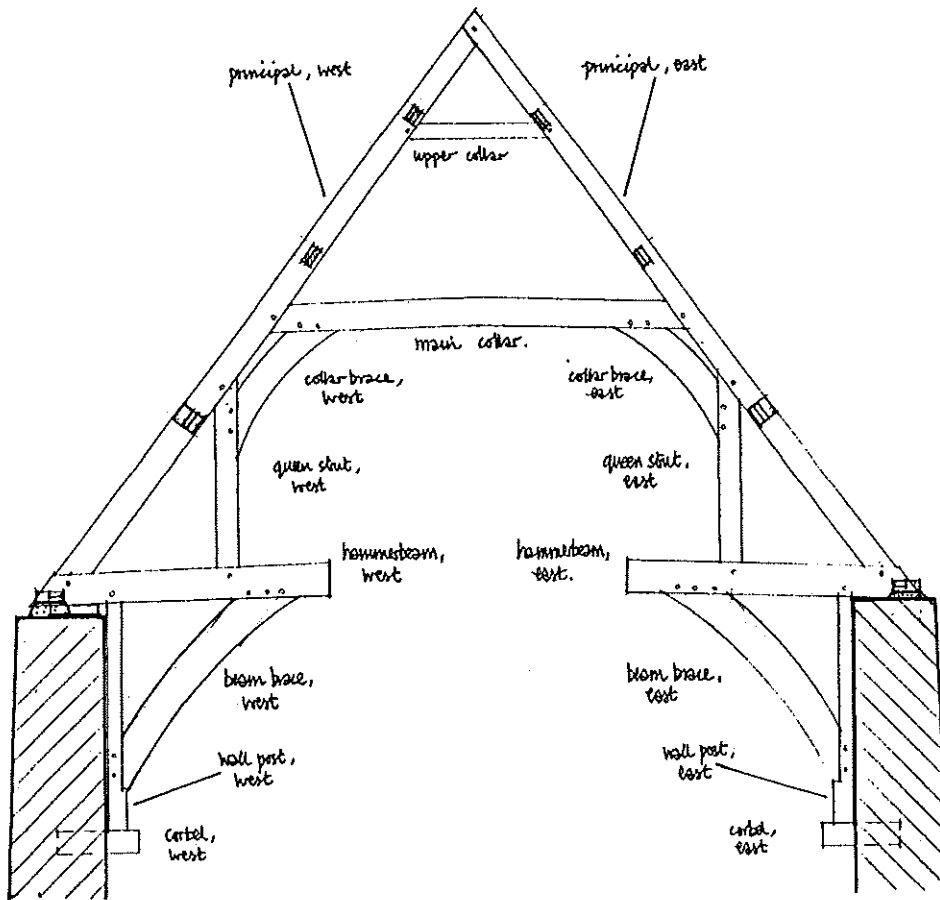


**Figure 3a-c** Sketches of the three roof trusses types, showing nomenclature employed for their structural elements followed in Table 1, based on drawings kindly supplied by Anthony Rossi

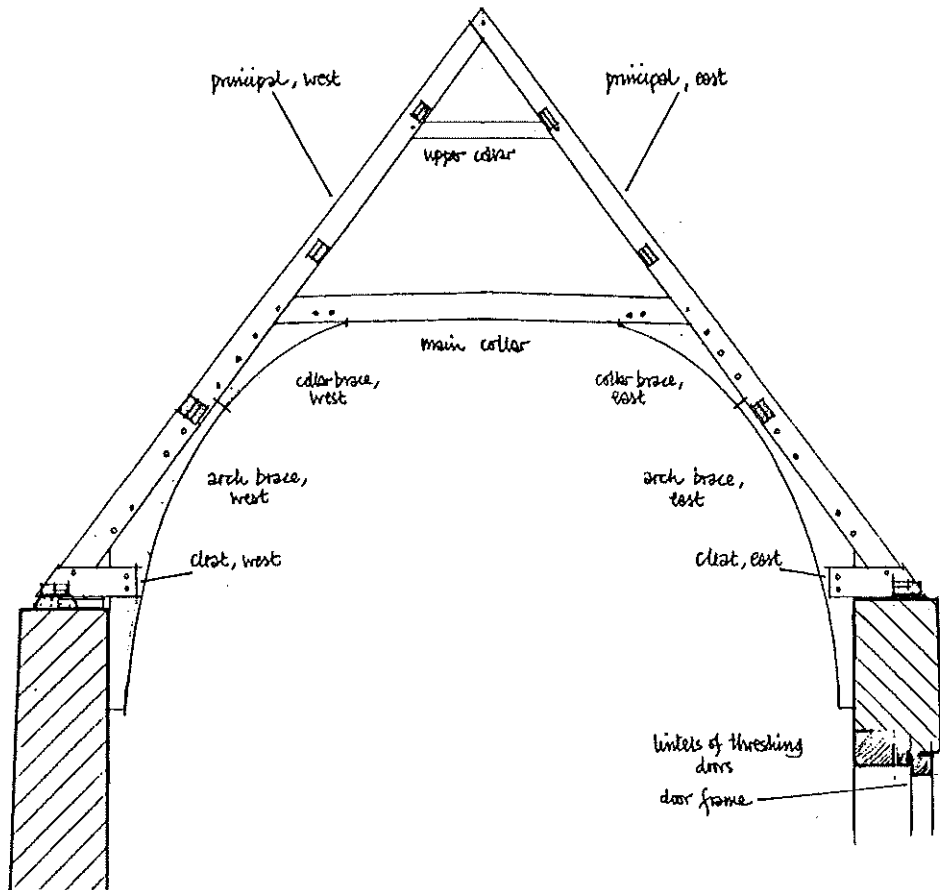
**Figure 3a** Truss type A, all odd numbered trusses



**Figure 3b** Truss type B, all even numbered trusses except 6 and 16



**Figure 3c** Truss type C, truss numbers 6 and 16



**Figure 4a-b** Sketches of the two side elevations of the barn, showing the approximate locations of the sampled corbel, door, and lintel timbers, based on drawings kindly supplied by Anthony Rossi, scans kindly supplied by English Heritage.

**Figure 4a** West side

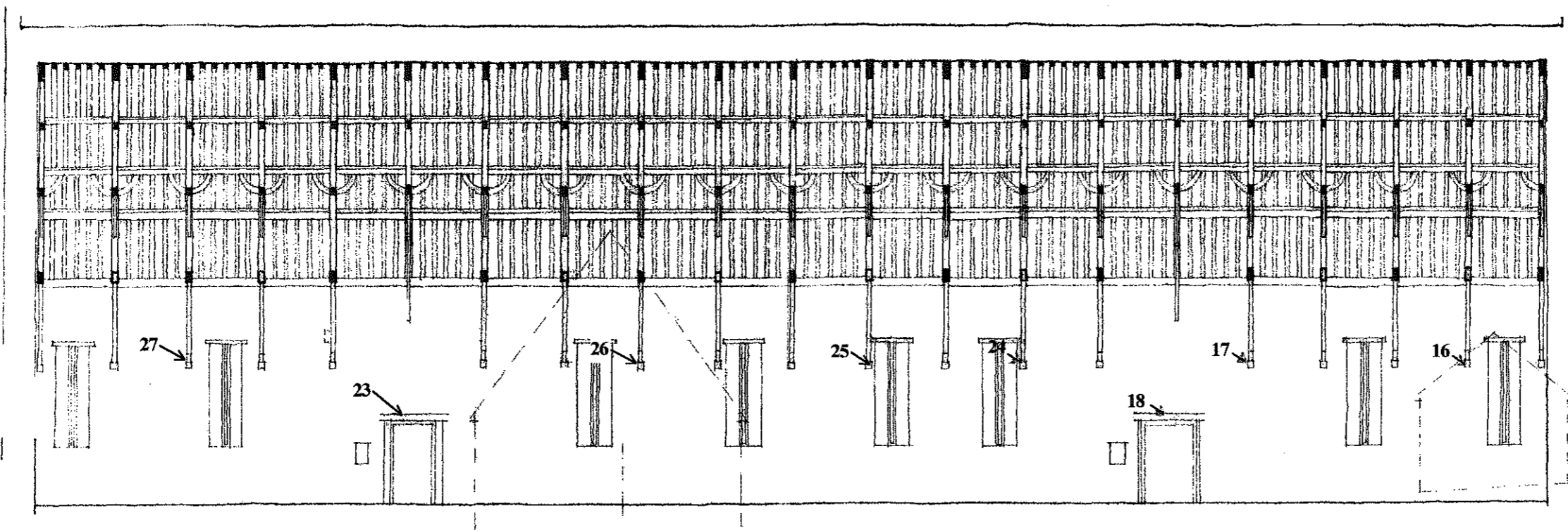
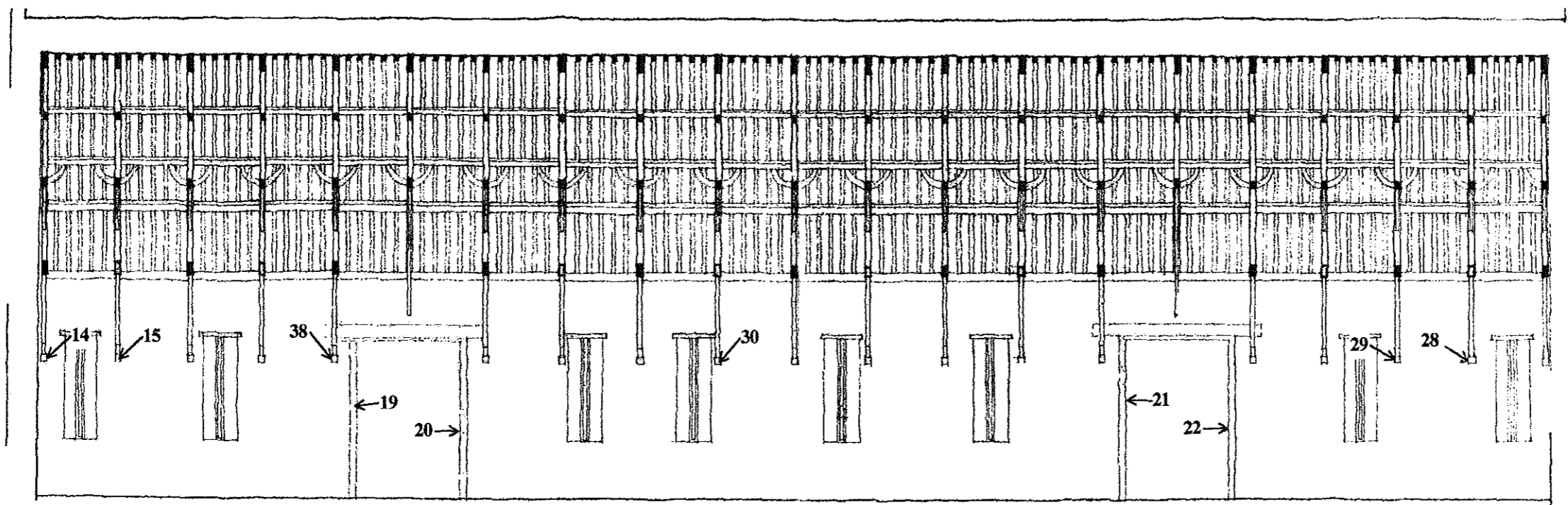


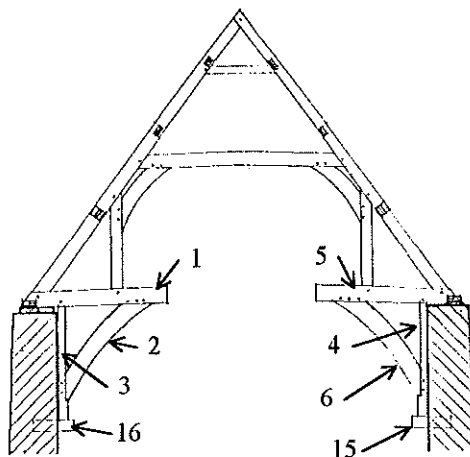
Figure 4b East side



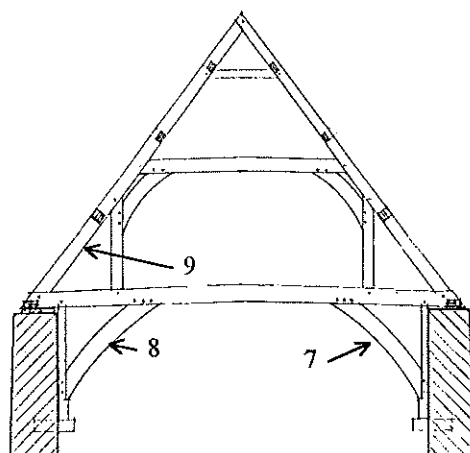


**Figure 5a-j** Sketches of trusses 2 to 5 and 7 to 12 inclusive showing the approximate locations of samples 1-13, 31-37, and 39-42 inclusive, based on drawings kindly supplied by Anthony Rossi. Note that the trusses where only the corbels were sampled are not covered by these sketches, please refer to Fig 4 for the locations of these.

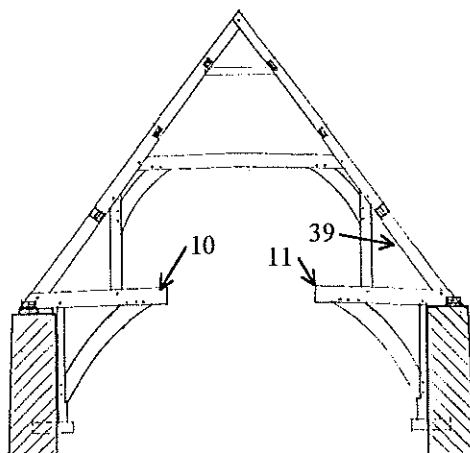
**Figure 5a** Truss 2, looking north



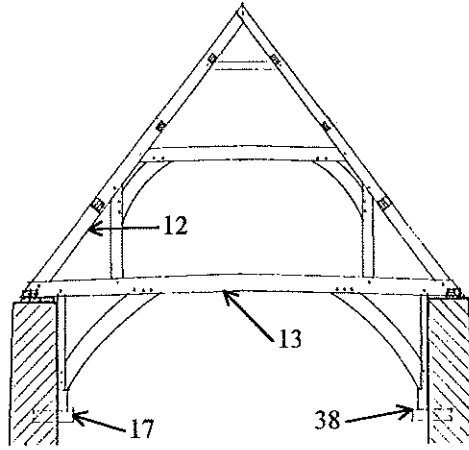
**Figure 5b** Truss 3, looking north



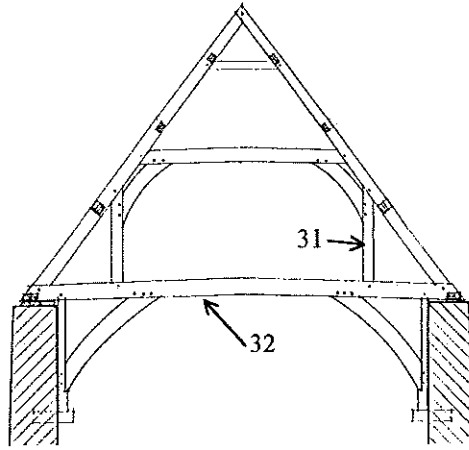
**Figure 5c** Truss 4, looking north



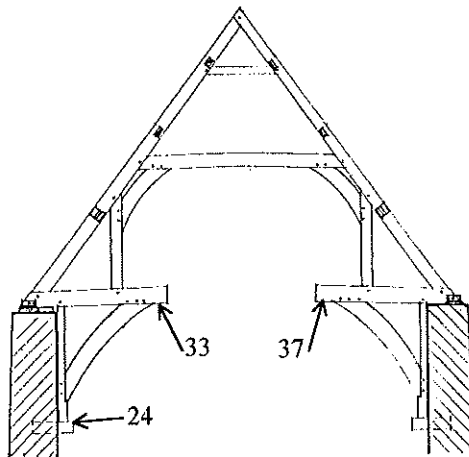
**Figure 5d** Truss 5, looking north



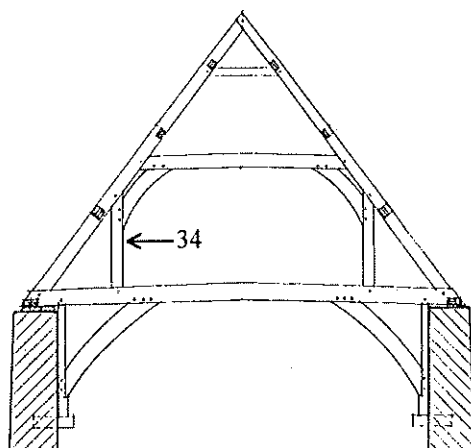
**Figure 5e** Truss 7, looking north



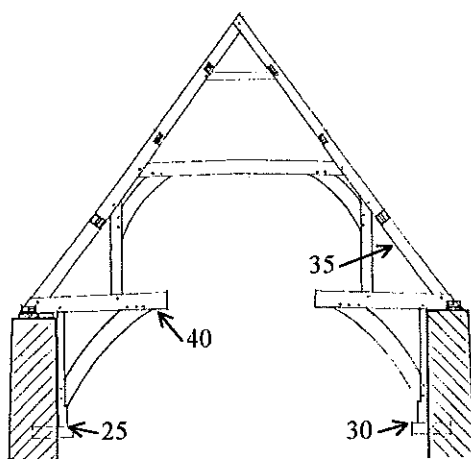
**Figure 5f** Truss 8, looking north



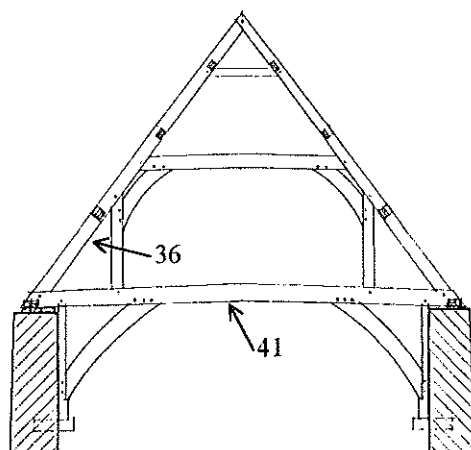
**Figure 5g** Truss 9, looking north



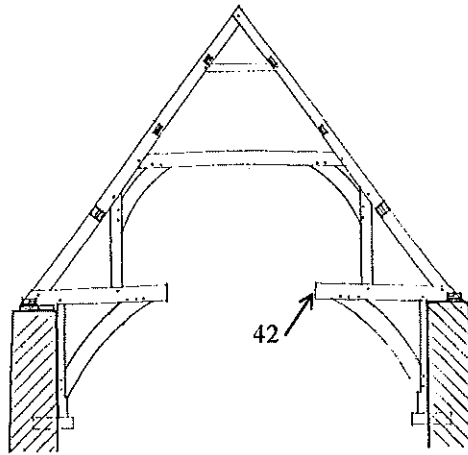
**Figure 5h** Truss 10, looking north



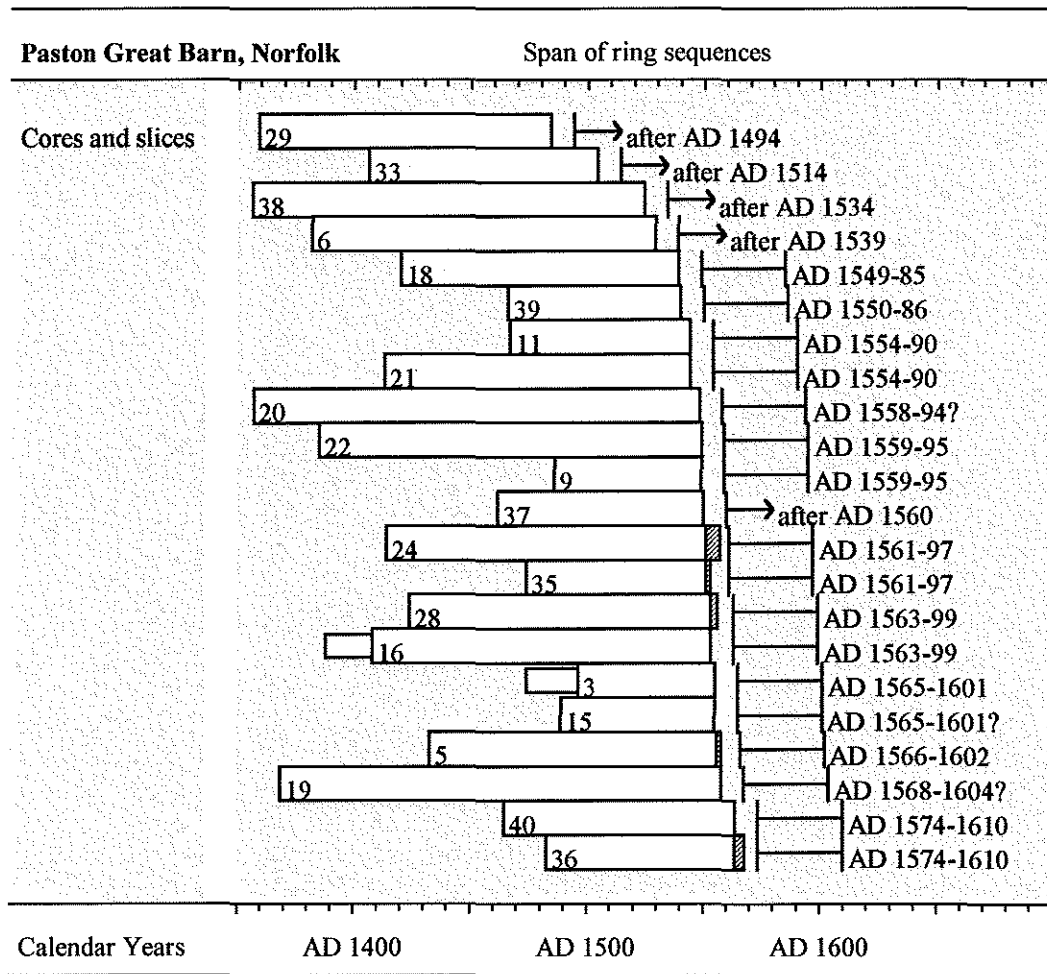
**Figure 5i** Truss 11, looking north



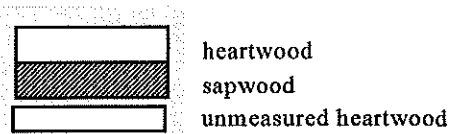
**Figure 5j** Truss 12, looking north



**Figure 6** Bar diagram showing the chronological positions of the 22 dated timbers. The estimated felling period for each sequence is also shown



**KEY**



**Table 1** List of samples

Core No	Origin of core/slice	Cross-section size (mm)	Cross-section of tree	Total rings	Sapwood rings	Average ring width (mm/year)	Date of sequence	Felling period
1	Truss 2: west hammer-beam	300 x 250	Quarter	102	h/s	2.48	Undated	
2	Truss 2: west beam brace	325 x 125	Quarter	91	h/s	2.55	Undated	
3	Truss 2: west wall post	200 x 120	Quarter	60	h/s	1.68	AD 1496-1555	AD 1565-1601
4	Truss 2: east wall post	195 x 120	Quarter	85	h/s	1.71	Undated	
5	Truss 2: east hammer-beam	280 x 230	Quarter	126	2	1.32	AD 1433-1558	AD 1566-1602
6	Truss 2: east beam brace	280 x 100	Half	148	-	0.74	AD 1382-1529	after AD 1539
7	Truss 3: east beam brace	290 x 120	Half	73	h/s	1.30	Undated	
8	Truss 3: west beam brace	320 x 115	Half	99	25	1.23	Undated	
9	Truss 3: west principal rafter	240 x 230	Whole	64	h/s	1.50	AD 1486-1549	AD 1559-95
10	Truss 4: west hammer-beam	290 x 245	Halved	66	h/s	2.08	Undated	
11	Truss 4: east hammer-beam	280 x 240	Whole	78	h/s	1.98	AD 1467-1544	AD 1554-90
12	Truss 5: west principal rafter	240 x 200	Whole	87	h/s	1.46	Undated	
13	Truss 5: tie-beam	320 x 240	Half				Not measured	
14	Truss 1: east corbel	260 x 200	Whole				Not measured	
15	Truss 2: east corbel	270 x 200	Whole	67	?h/s	1.64	AD 1489-1555	AD 1565-1601
16	Truss 2: west corbel	270 x 200	Half	146	h/s	0.93	AD 1408-1553	AD 1563-99
17	Truss 5: west corbel	260 x 200	Whole				Not measured	
18	East lintel of north-west door	390 x 220	Half	120	h/s	1.43	AD 1420-1539	AD 1549-85
19	North door post of north-east door	200 x 190	Quarter	190	?h/s	1.11	AD 1369-1558	AD 1568-1604
20	South door post of north-east door	200 x 190	Quarter	192	?h/s	1.02	AD 1357-1548	AD 1558-94
21	North door post of south-east door	235 x 200	Quarter	132	h/s	1.49	AD 1413-1544	AD 1554-90
22	South door post of south-east door	235 x 200	Quarter	165	h/s	1.21	AD 1385-1549	AD 1559-95
23	East lintel of south-west door	385 x 140	Half				Not measured	
24	Truss 8: west corbel	270 x 195	Whole	144	6	0.90	AD 1414-1557	AD 1561-97
25	Truss 10: west corbel	300 x 200	Whole	110	6	0.89	Undated	
26	Truss 13: west corbel	270 x 180	Whole	65	?h/s	1.74	Undated	
27	Truss 19: west corbel	280 x 195	Whole	47	?h/s	1.91	Undated	
28	Truss 20: east corbel	265 x 185	Half	133	3	1.07	AD 1424-1556	AD 1563-99
29	Truss 19: east corbel	280 x 195	Whole	126	-	0.90	AD 1359-1484	after AD 1494
30	Truss 10: east corbel	280 x 195	Whole				Not measured	
31	Truss 7: east queen strut	235 x 145	Whole	57	h/s	1.68	Undated	
32	Truss 7: tie-beam	300 x 280	Half	89	h/s	3.14	Undated	
33	Truss 8: west hammer-beam	285 x 230	Half	99	-	1.22	AD 1406-1504	after AD 1514
34	Truss 9: west queen strut	220 x 145	Half				Not measured	
35	Truss 10: east principal rafter	Slice *		80	2	1.64	AD 1474-1553	AD 1561-97
36	Truss 11: west principal rafter	Slice *		86	4	1.62	AD 1483-1568	AD 1574-1610
37	Truss 8: east hammer-beam	Slice *		89	-	2.05	AD 1462-1550	after AD 1560
38	Truss 5: east corbel	Slice *		169	-	0.90	AD 1356-1524	after AD 1534
39	Truss 4: east principal rafter	Slice *		75	h/s	1.67	AD 1466-1540	AD 1550-86
40	Truss 10: west hammer-beam	285 x 240	Whole	100	h/s	1.69	AD 1465-1564	AD 1574-1610
41	Truss 11: tie-beam	330 x 310	Whole	64	-	1.93	Undated	
42	Truss 12: east hammer-beam	240 x 240	Whole	88	?h/s	1.58	Undated	

Total rings = all measured rings, +(value) = additional rings were only counted, the felling period column is calculated using these additional rings.

Sapwood rings: h/s heartwood/sapwood boundary, h/s? possible heartwood/sapwood boundary.

\* Samples 35-39 inclusive were recovered from fragmentary sections of timber removed during the remedial works, precise origin uncertain, dimensions were not taken



**Table 3**

Dating the mean sequence PASTON, AD 1356-1568 inclusive. *t*-values with independent reference chronologies

Area	Reference chronology	<i>t</i> -values
East Midlands	East Midlands Regional Master (Laxton and Litton 1988)	8.17
Essex	Navestock Church (Tyers 1999b)	5.25
Kent	Kent Regional Master (Laxton and Litton 1989)	5.61
London	London Regional Master (author unpubl)	7.10
Norfolk	King's Lynn, Marriot's Warehouse (Tyers 1999a)	6.14
Staffordshire	Burton-on-Trent, Sinai Park (Tyers 1997b)	5.93
	Black Ladies, near Brewood (Tyers 1999c)	5.93
Warwickshire	Astley Castle (Howard <i>et al</i> 1997)	6.92
Yorkshire	Ripon, Thorpe Prebend (Boswijk 1998)	5.86
Netherlands	S Netherlands Regional Master (Jansma pers comm 1994)	5.55
Germany	NW German Regional Master (Hollstein 1980)	5.99

**Table 4**

Ring-width data from site master PASTON, dated AD 1356-1568 inclusive

Date	Ring widths (0.01mm)										No of samples									
AD 1356						177	144	92	182	171						1	2	2	3	3
	142	201	141	179	168	186	154	143	153	133	3	3	3	3	3	3	3	3	4	4
	92	177	159	154	115	110	115	143	124	163	4	4	4	4	4	4	4	4	4	4
	147	144	144	113	101	127	125	109	76	109	4	5	5	5	6	6	6	6	6	6
	111	106	86	91	82	119	92	136	143	133	6	6	6	6	6	6	6	6	6	6
AD 1401	58	76	72	103	88	79	65	79	83	104	6	6	6	6	6	7	7	8	8	8
	90	89	90	85	86	92	75	94	80	79	8	8	9	10	10	10	10	10	10	11
	99	96	113	108	95	85	82	91	114	78	11	11	11	12	12	12	12	12	12	12
	69	72	78	67	78	73	85	83	67	79	12	12	13	13	13	13	13	13	13	13
	83	71	84	84	82	80	95	101	119	110	13	13	13	13	13	13	13	13	13	13
AD 1451	125	103	102	126	109	111	97	100	89	112	13	13	13	13	13	13	13	13	13	13
	109	101	76	82	78	101	125	150	146	144	13	14	14	14	15	16	17	17	17	17
	131	156	143	165	190	150	146	134	163	150	17	17	17	18	18	18	18	18	18	18
	158	174	187	186	169	190	233	204	189	151	18	18	19	19	18	19	19	19	20	20
	165	127	153	163	181	194	177	129	145	134	20	20	20	20	20	21	21	21	21	21
AD 1501	135	161	133	139	142	164	124	125	153	129	21	21	21	21	20	20	20	20	20	20
	143	135	127	119	116	123	130	160	132	121	20	20	20	20	20	20	20	20	20	20
	122	146	120	139	122	134	132	125	120	104	20	20	20	20	19	19	19	19	19	18
	127	106	105	115	126	128	124	108	148	153	18	18	18	18	18	18	18	18	18	17
	142	121	126	125	126	118	90	102	125	107	16	16	16	16	14	14	14	14	13	11
AD 1551	93	89	84	86	108	100	96	128	128	145	10	10	10	8	8	6	5	4	2	2
	124	131	122	169	189	210	278	268			2	2	2	2	1	1	1	1		