

Centre for Archaeology Report 69/2002

**Dendrochronological Analysis of Conifer Timbers from Danson
House and Danson Stables, Bexley, Kent**

Cathy Groves

© English Heritage 2002

ISSN 1473-9224

The Centre for Archaeology Reports Series incorporates the former Ancient Monuments Laboratory Report Series. Copies of Ancient Monuments Laboratory Reports will continue to be available from the Centre for Archaeology (see back of cover for details).

Dendrochronological Analysis of Conifer Timbers from Danson House and Danson Stables, Bexley, Kent

Cathy Groves

Summary

An English Heritage funded research project is currently investigating the viability of dendrochronological analysis of conifer timbers imported into England. Limited success in previous studies led to the selection of Danson House and Stables, the timber elements of which were predominantly conifers, for inclusion in the project. These conifer timbers constitute a valuable data resource for the research project as well as having some potential to aid the archaeological understanding of the complex. Two tree-ring chronologies were produced. The first includes data from 24 timbers from the primary construction phase of Danson House and dates to the period AD 1489 - 1758. The second consists of four timbers associated with the raising of the bays in the house, and spans the period AD 1545 - 1767. The likely provenance for both of these groups of timbers is mainland Europe with the former probably originating in Belarus and the latter potentially coming from northern Poland or slightly further east. In addition the ring sequence from a single roofboard from the house was dated to AD 1494 - 1705, with a likely provenance in central-west Sweden/Norway. Unfortunately no tree-ring dating evidence could be provided for Danson Stables. The widespread lack of bark edge prevents the production of precise felling dates and although the tree-ring results produced for the Danson House timbers support the documentary evidence they cannot refine it. The successful production of two dated site chronologies, the dating of one other timber, and the identification of a number of different sources of timber emphasises the potential of the dendrochronological analysis of imported conifer timbers.

Keywords

Dendrochronology
Standing Building

Author's address

Sheffield Dendrochronology Laboratory, Research School of Archaeology & Archaeological Science,
Department of Archaeology & Prehistory, University of Sheffield, West Court, 2 Mappin Street, Sheffield,
S1 4DT, Tel/Fax: 0114 276 3146, Email: c.m.groves@sheffield.ac.uk

Many CFA reports are interim reports which make available the results of specialist investigations in advance of full publication. They are not subject to external refereeing, and their conclusions may sometimes have to be modified in the light of archaeological information that was not available at the time of the investigation. Readers are therefore advised to consult the author before citing the report in any publication and to consult the final excavation report when available.

Opinions expressed in CFA reports are those of the author and are not necessarily those of English Heritage.

**DENDROCHRONOLOGICAL ANALYSIS OF CONIFER TIMBERS FROM DANSON HOUSE AND DANSON
STABLES, BEXLEY, KENT**

Introduction

This document is a technical archive report on the dendrochronological analysis of timbers from Danson House and Danson Stables, Bexley, Kent. It is beyond the dendrochronological brief to describe the buildings in detail or to undertake the production of detailed drawings. As part of a multidisciplinary study of the buildings, elements of this report will be combined with detailed descriptions, drawings, and other technical reports to form a comprehensive publication (Lea and Miele pers comm). The information produced will also be incorporated into an on-going dendrochronological research project. The conclusions presented here may therefore have to be modified in the light of subsequent work.

A brief history and architectural description of relevant areas of the building, summarised from Lea and Miele (pers comm) are presented below, followed by a resume of the dendrochronological conifer programme, and finally the aims of the dendrochronological analysis.

Danson House and Stables

Danson House is a grade I listed Palladian villa (TQ 4727 7517) with an associated stable block (TQ 4721 7535), listed grade II, lying some 180m to the north west in Danson Park (Fig 1). Danson House (Fig 2) replaced a previous house, located in a less prominent position, where the lake is now located within the park. The new house was designed as a villa by Robert Taylor and was built for John Boyd a city merchant and director of the East India Company. The complex consisted of a villa augmented by two service wings, one for stabling and one for offices. Documentary evidence indicates that the carcass of the house was begun in AD 1762 and the service wings by AD 1766. The work of finishing the principal interiors was undertaken during AD 1766. The upper sections of the canted side bays were raised in *c* AD 1775.

John Boyd senior died in AD 1800 and his son, John Boyd junior, took over the estate. He immediately undertook a programme of alteration and enhancement that, according to expenditure records, peaks in the years AD 1802-4. This included the removal of both service wings for which no above-ground evidence survives. The present stable block (Fig 3), an outstanding example of late Georgian estate architecture, was probably built in *c* AD 1802-4. The entire estate was sold on to John Johnston in AD 1806 and then again to Alfred Bean in AD 1862.

The construction of the stable block roof appears to be uniform throughout suggesting that it is the product of a single building phase that incorporates some reused timber. The roof above the central block consists of six king-post trusses, whilst that of each wing comprises five king-post trusses. The trusses rest on timber wall plates on the inner face and these support purlins set immediately above the tiebeams and halved over the mid point of the principal rafters. The rafters meet at the ridge board. The appearance of the trusses is generally consistent with a date of between the mid-eighteenth and nineteenth centuries. The reuse of masonry and the fact that the roof spans in the present stable block are the same as those in the original wings attached to the house, has led to the suggestion that the original wing roof trusses were reused in the construction of the detached stable block. However the ironwork from the original wings would probably have been flat section iron straps, as found at Taylor's other known buildings, whereas the stables have iron bolts that tie the king-post to the tiebeam. Consequently it is possible that the stable block roof was constructed from fresh timber in AD 1802-4 or that it was entirely replaced in AD 1863, a date indicated by an inscription carved into one of the trusses that may relate to either a total rebuild or a general overhaul of glazing and internal arrangements.

English Heritage acquired the leases for the house and stable block as part of the Buildings at Risk initiative and undertook a major programme of repair on the house during AD 1996-7. The brewers Bass took on the lease of the stable block and carried out repairs during AD 1997 prior to its opening as a public house.

Dendrochronology, Conifers, and Importation

British dendrochronology is based on the analysis of oak and is steadily revealing an increasingly detailed picture of the changing nature of timber size and availability (Tyers 1991a; Tyers *et al* 1994), as well as providing information concerning the source of timber and its acquisition from increasingly distant sources (Groves 2000a; Tyers 2000; Bridge 2000). In the post-medieval period, in both rural and urban contexts, there was not only a noticeable rise in the occurrence of native hardwood species other than oak but also a dramatic escalation in the utilisation of conifer timbers which, in the absence of native species, are presumed to have been mostly imported. Scots Pine (*Pinus sylvestris* L.), for instance, grew in England up to the Bronze Age but, apart from some possible isolated relict forests, it was not present until reintroduced around AD 1500 (eg Clapham *et al* 1989). Other species such as spruce and European larch were introduced in the early to mid-sixteenth century and early-seventeenth century respectively (Evelyn 1729; James 1990, 164 184).

In the medieval period the development of agriculture and the steadily increasing demand for building timber caused considerable deforestation. In addition, the requirements of industry and warfare

ensured that the need for timber remained high. This meant exploiting new sources of timber, and for that reason it became an increasingly important item in north European trade. Documentary sources indicate that timber was imported through organised routes as early as the thirteenth century (Simpson pers comm). Initially it was brought in for specialist purposes such as oak planking and formed only part of the cargo, but by the mid-eighteenth century a number of Baltic ports were sending cargoes consisting solely of timber to England, and these were dominated by material suitable for general construction purposes (Dollinger 1970; Kent 1973; Fedorowicz 1980). This change from importing specialist timber to that required for general construction purposes, usually conifer baulks and boards, is almost certainly an indication of the depleted state of our local woodland resources by that time.

The advances in dendrochronology over the last decade have seen the development and exchange of a large network of oak chronologies covering northern Europe. This has allowed oak timbers, that were exported considerable distances away from their region of origin to be dated, and has had the added bonus of identifying the geographical region from which they were derived (Bonde and Jensen 1995; Bonde *et al* 1997). This increasingly large body of data is currently dominated by groups of timbers imported into various parts of north-west Europe, probably from the eastern Baltic region (Baillie 1984; Wazny 1990). In Britain dendrochronology has identified eastern Baltic oak boards being used for panel paintings, coffins, boat planking, barrel staves, wall and ceiling panelling, doors, altars, and decorative screens. Documentary evidence indicates its importation all down the eastern seaboard of both England and Scotland, and round the south and west coasts as far as Bristol (Simpson pers comm). Dendrochronological evidence has demonstrated the presence of eastern Baltic oak imports at various locations in England and Scotland, ranging from east coast ports as far north as Aberdeen, locations further inland, and as far west as Exeter (Tyers 1991b; Howard *et al* 1995; Lewis 1995; Mills and Crone 1998; Tyers 2000; Groves forthcoming).

In the mid-seventeenth century there was a marked shift in patterns of trade. Ports such as Gdansk and others in the eastern Baltic went into recession, perhaps as a result of the exhaustion of forests but also due to the changing political circumstances. Although small quantities of conifer timbers are thought to have been imported prior to this, it is only in the mid-seventeenth century that the trade in conifer timber flourishes, with Norway becoming the leading timber supplier to England (Kent 1973). Initially the Norwegian forests could satisfy England's requirements, though a small percentage of timber came in as supplementary cargoes from Sweden. However by the mid eighteenth century the structure of English imports had changed considerably with regard to both the sources of supply and the types of timber supplied (Zunde 1998a). Ports on the Baltic and White seas began to rival Norwegian ports and Norway lost its pre-eminence as the main timber supplier to England. Conifer baulks suitable for general construction work started to form a significant proportion of the total

exports and to play an important part in the increased prominence of Baltic ports, although Norway retained its dominance in the export of deals. However, by the late eighteenth and early nineteenth centuries the focus of trade shifted again as North American imports increased in importance. By the AD 1820s North America had become England's main timber supplier, although northern Europe still provided timber of a more specialist nature.

Conifers are routinely used for dating purposes elsewhere in Europe (Storsletten and Thun 1993). Norway and Sweden, for instance, lie at the northern limits of the natural distribution of oaks, and therefore dendrochronologists in those countries have concentrated their efforts on the species of conifers which were readily available for construction. This fact, combined with the proven ability to date oak timbers imported into Britain from countries around the southern and eastern shores of the Baltic Sea, suggests that the conifers imported and subsequently used extensively in many post-medieval buildings may also be dateable.

Over the past few years an English Heritage funded research project has been investigating the viability of analysing conifers used in historic contexts (Groves 1997a; Groves 2000b; Groves 2000c). The primary aim of this is to extend the scope of British dendrochronology to incorporate structures built of coniferous timber. In addition, as the majority of medieval and post-medieval conifer timbers used for building are likely to be imported, successful dating has the added advantage of providing information about the source of timber, and hence the trade in timber during these periods. It was also recognised that the work might reveal information concerning the production and utilisation of timber from plantations of non-native species grown in England that would enhance our understanding of the history of forestry. The English Heritage project is now complemented by a similar project in Scotland being undertaken by Anne Crone and Coralie Mills of AOC Archaeology.

Aims

As part of the Buildings at Risk initiative a large detailed programme of analysis and research was undertaken on Danson House and Stables by Richard Lea and Chris Miele of English Heritage in conjunction with a major programme of repairs to the buildings. The excellent documentary evidence which indicated the likely dates of construction and subsequent modification to the buildings, combined with the repair programme, which allowed widespread, albeit temporary, access to timbers, meant that this project provided an excellent opportunity to further the research project on the dendrochronological analysis of conifers.

The analysis was undertaken with the following aims:

1. to determine the wood type and, where possible, the actual species

2. to provide dates for timbers and if possible additional dating evidence
3. to determine the geographical source of the timbers and identify any variation in source through time

Three areas of specific interest, as far as the additional dating evidence was concerned, were indicated by Richard Lea: the floor and roof timbers of the house thought on documentary information to be AD1762-6; the raising of the canted side bays thought to be *circa* AD 1775; the stable roof thought to date to either AD 1802-4 or AD 1863 but potentially incorporating reused timbers from *circa* AD 1767.

These aims would be considered fairly routine if the wood was oak but it was accepted that they were somewhat ambitious when dealing with an historic conifer assemblage in England.

Methodology

Professional practice at the Sheffield Dendrochronology Laboratory follows that described in English Heritage (1998) although some modifications are required when dealing with conifer assemblages. The following summarises relevant methodological details used for the dendrochronological analysis of Danson House and Stables.

Prior to sampling an assessment survey was undertaken in order to identify the presence of timbers suitable for analysis and to allow a suitable sampling strategy to be formulated. The house was reasonably readily accessible, although some areas were out of bounds for safety reasons, but the stables had very limited access due to the dangerous condition of the buildings consequently compromising the extent of the assessment. Discussions with Scandinavian and eastern Baltic colleagues, all of whom use similar analytical techniques to those employed here, have indicated that conifer timbers with less than 50 annual growth rings are generally considered unsuitable for analysis as their ring patterns may not be unique. Thus timbers were sought which had at least 50 rings and if possible had bark/bark edge surviving. The sampling strategy is usually designed to address the specific archaeological issues relating to the understanding of a building but in this instance the aims of the conifer research project were of primary importance, whilst still taking into account access and aesthetics issues.

In standing buildings samples are generally removed from selected timbers in the form of either cross-sectional slices or cores. Slices are taken from timbers that are either wholly or partially replaced during restoration, whereas cores are removed from timbers that will remain *in situ*. The cores are taken, using a 16mm diameter corer attached to an electric drill, in a position and direction most

suitable for maximising the number of rings in the sample, whilst ensuring the presence of bark edge whenever possible.

The ring sequence of each sample was revealed by sanding the cross-sectional surfaces using progressively finer grits until the growth rings were clearly defined. The wood type of each sample was determined through reference material in the form of permanent slides, an identification key (Schweingruber 1990), and a computer database (GUESS - see Wheeler *et al* 1986). Any samples which fail to contain the minimum number of rings or have unclear ring sequences are rejected. The sequence of growth rings in the samples selected for further analysis were measured to an accuracy of 0.01mm using a purpose built travelling stage attached to a microcomputer based measuring system (Tyers 1997; 1999). The ring sequences were plotted onto semi-logarithmic graph paper to enable visual comparisons to be made between them. In addition, cross-correlation algorithms (Baillie and Pilcher 1973; Munro 1984) were employed to search for positions where the ring sequences were highly correlated. The Student's *t* test is then used as a significance test on the correlation coefficient and those quoted below are derived from the original CROS algorithm (Baillie and Pilcher 1973). With oak ring sequences a *t* value of 3.5 or over is usually indicative of a good match (Baillie 1982, 82-5). These statistical tests were designed for use with oak but some species, such as pine or beech, tend to exhibit much greater differences between successive rings than is normal for oak which results in a noticeable increase in the *t* values calculated. Discussions with various Scandinavian and eastern Baltic colleagues indicate that the equivalent to the 'oak 3.5' varies slightly between laboratories, with CROS *t* values ranging from 4.0 to 6.0 suggested (eg Zetterberg 1988), with 4.0 commonly used. Consequently in this analysis a *t* value of 4.0 or over is considered indicative of a good match, provided that high *t* values are obtained at the same relative or absolute position with a range of independent sequences and that the visual match is satisfactory.

Dating is usually achieved by cross-correlating, or crossmatching, ring sequences within a phase or structure and combining the matching patterns to form a phase or structure master curve. This master curve and any remaining unmatched ring sequences are then tested against a range of reference chronologies, using the same matching criteria as above. The position at which all the criteria are met provides the calendar dates for the ring sequence. A master curve is used for absolute dating purposes whenever possible as it enhances the common climatic signal and reduces the background noise resulting from the local growth conditions of individual trees.

During the crossmatching stage of the analysis an additional important element of tree-ring analysis is the identification of 'same-tree' timber groups. The identification of 'same-tree' groups is based on very high levels of similarity in year-to-year variation, longer term growth trends, and anatomical

anomalies. Such information should ideally be used to support possible 'same-tree' groups identified from similarities in the patterns of knots/branches during detailed recording of timbers for technological and woodland characterisation studies. Oak timbers generally derived from the same parent log generally have t values of greater than 10.0, though lower t values do not necessarily exclude the possibility. It is a balance of the range of information available that provides the 'same-tree' link. At present the equivalent value for post-medieval conifers from Scandinavia and the eastern Baltic is not known and of course it may vary between species and potentially geographical location. Previous work on sub-fossil pines in the British Isles suggests that t values in the order of 10-15 or over probably indicate that the samples/timbers were derived from the same tree (Boswijk 1998). This is supported by the analysis of a small number of known duplicate samples from coffin boards (Groves and Boswijk 1998). However as the conifer research project develops it is hoped to obtain more detailed information from the analyses carried out in relevant countries and therefore this value may be revised.

The crossdating process provides precise calendar dates only for the rings present in the timber. The nature of the final ring in the sequence determines whether the date of this ring also represents the year the timber was felled. Species such as pine consist of inner inert heartwood and an outer band of active sapwood. Information provided by other European colleagues indicates that the number of sapwood rings in conifers is highly variable between regions and periods and is strongly influenced by the age of the trees (eg Zetterberg and Hiekkänen 1990). For instance the number of sapwood rings in northern Sweden tends to be over 100, where as in the south (ie south of Stockholm) it is generally circa 50 ± 30 (Eggertson pers comm). Consequently if the timbers originate from an area where a sapwood estimate does exist then this can be used to interpret the final ring dates. If the sample ends in the heartwood of the original tree, a *terminus post quem* for the felling of the tree is indicated by the date of the last ring plus the addition of the minimum expected number of sapwood rings that may be missing. This is the date after which the timber was felled but the actual felling date may be many decades later depending on the number of outer rings removed during timber conversion. Where some of the outer sapwood or the heartwood/sapwood boundary survives on the sample, a felling date range can be calculated using the maximum and minimum number of sapwood rings likely to have been present. If the bark-edge survives, then a felling date can be directly obtained from the date of the last surviving ring.

The dates obtained by the technique do not by themselves necessarily indicate the date of the structure from which they are derived. Evidence indicates that seasoning of timber for structural purposes was a fairly rare occurrence until relatively recent times and medieval timber was generally felled as required and used whilst green (eg Rackham 1990; Charles and Charles 1995). However it is

necessary to incorporate other specialist evidence concerning the reuse of timbers and the repairs or modifications of structures, as well as factors such as stockpiling, seasoning and, of particular relevance here, transport, before the dendrochronological felling dates given can be reliably interpreted as reflecting the construction date of phases within a structure.

Results

Danson House

The initial assessment visit to Danson House established that there were clearly sufficient timber elements with enough numbers of rings to attempt dendrochronological analysis, though there was a notable lack of bark or bark edge on exposed timbers. It was clear that access to some timbers of potential interest would not be possible due to problems of safe access or, more often, simply because they would not be adequately exposed during the renovation works.

The sampling strategy for the house was adapted as necessary during the sampling visits to make allowances for areas that remained inaccessible. A series of 50 *in situ* timbers were selected, the locations of which are indicated in Figures 4-12 and Table 1. Sampling was concentrated at the bedroom level as the ceiling beams (attic-level floor), partition wall framing, and bay roofs were exposed and accessible. Of the three canted bays only the east bay roof was suitable for coring as the other bays contained modern replacement timbers. No timbers were exposed at the principal level, though it was possible to access one of the major ceiling beams from above where an area of floor boarding had been lifted. The only exposed timbers at ground level were replacement ceiling beams. The roof proved equally problematic as safe access was severely restricted and the scantling of many of the rafters was such that sampling using standard coring equipment could have affected structural integrity. In addition the small scantling meant that these timbers would generally contain fewer growth rings. It had been hoped that a whole series of samples could be obtained from the principal level floorboards, thought to be original to the building, as these had been lifted. However in view of these proving entirely sound, unlike some of their supporting beams, the decision to relay them precluded the possibility of removing even thin cross-sectional slices from their ends. A series of 19 cross-sectional slices were however removed from various *ex situ* timbers. Richard Lea was able to identify the likely function and location within the building for several of these timbers (Table 1).

Microscopic identification of the timbers indicated that all samples from the house were of a single wood type. This type is *Pinus sylvestris* L. (Scots pine), *P. mugo* Turra (Mountain pine), *P. nigra* Arnold (Black pine) or *P. resinosa* (Red pine). *P. sylvestris* and *P. mugo* cannot be distinguished on the basis of their wood anatomy but *P. mugo* is a dwarfed tree with dense shrubby growth sometimes multi-trunked and therefore not suitable for structural timber. *P. sylvestris* occurs throughout Europe;

P. mugo and *P. nigra* are native to central/southern Europe; and *P. resinosa* is a native of North America. *P. nigra* can sometimes be distinguished from *P. mugo* and *P. sylvestris* as the early/latewood transition may be more abrupt than in the other two species (Schweingruber 1990, 131). *P. resinosa* cannot normally be distinguished from these three European species on the basis of its wood anatomy. Thus it was not microscopically possible to determine the wood type down to species level. However taking into account the additional evidence concerning geographical source provided by the successful dating and hence provenancing of 42% of the timbers, it seems highly likely that they are *P. sylvestris* L..

The total number of samples obtained from the house was 69: 59 samples, including 12 *ex situ* timbers, were associated with the primary construction; five samples, including two *ex situ* timbers which might have been reused from phase one, were thought to be from the raising of the bays; and five samples, all from *ex situ* timbers, were of unknown function. Details of the samples are provided in Table 1. As the documentary evidence indicated that the two phases date to within about a decade of each other, the analysis was undertaken on the assemblage as a whole rather than by group.

All 69 samples were suitable for measurement. The ring sequences of 29 samples crossmatched, including a number of possible ‘same-tree’ groups (Table 2; Fig 13). The ‘same-tree’ groups were combined to produce single-tree sequences before being incorporated into the 270-year site master chronology, DANSON1 (Table 3), so as to ensure that the master chronology was not biased towards individual timbers or trees. The ring sequences of a further four timbers were found to match, including a possible ‘same-tree’ pair (Table 4; Fig 14). These were combined to produce a 223-year site master chronology, DANSON2 (Table 5).

A further 16 samples formed five groups of matching ring sequences, some of which included possible same-tree pairs or groups (Fig 15; Tables 6-10). Each group of matched samples was combined to produce a site master chronology, DANSON3 – DANSON7 (Tables 11-15).

The site master chronologies and all unmatched individual ring sequences were compared but no additional conclusive crossmatching was established.

Since the timbers were likely to date to the mid-late eighteenth century, it was anticipated that they were probably imported as baulks from the eastern Baltic region, although the possibility of a Scandinavian origin could not be entirely discounted. The seven site master chronologies were therefore tested against an extensive range of northern European dated reference chronologies for pine spanning the last millennium. Consistent results were obtained with a number of reference

chronologies when DANSON1 spanned the period AD 1489-1758 and DANSON2 spanned the period AD 1545-1767 inclusive (Table 16). These results were independently confirmed by colleagues in Latvia, Norway, and Sweden.

The 25 unmatched individual ring sequences were compared to the same extensive range of reference chronologies. Consistent results were obtained for one of these samples, **55**, indicating that its ring sequence spans the period AD 1494-1705 (Table 16). Again this result was independently confirmed by colleagues in Latvia, Norway, and Sweden. No matching was identified for the remaining 24 sequences which were finally tested against a range of reference chronologies for various conifer species from throughout Europe and North America which generally span the last four centuries. No consistent results were produced so no additional dating evidence was obtained.

Stables

The initial assessment suggested that Danson Stables timbers were significantly less promising for dendrochronological analysis than the house timbers. Furthermore, close inspection of the timbers for assessment purposes was severely hampered by the presence of unsound floors throughout the building, some inaccessible rooms, as well as chronic pigeon infestation. The roof and ceiling timbers used appeared to have been derived from younger and faster grown trees with the result that many appeared borderline with respect to the numbers of rings present. The only possible exceptions to this were three decorated and clearly reused timbers present in the west range ground-floor ceiling. In view of the large number of trusses and ceiling timbers available it was felt that on closer inspection it may be possible to locate a reasonable number of suitable timbers.

It was anticipated that access to the stable roof and ceiling timbers for dendrochronological sampling would become possible during refurbishment. However due to a combination of circumstances sampling had to be undertaken towards the end of the refurbishment. Whilst the insertion of an air-conditioning system effectively prevented access for sampling to all but the east wing of the stable block through lack of space in which to manoeuvre the drill, coring attachment, and dendrochronologist. Sampling was therefore confined to the east wing. Close inspection of the roof timbers in the east wing confirmed the impression gained during the initial assessment. These timbers were, in marked contrast to those in the house, generally derived from fast grown timbers (ie wide rings) and the majority were clearly not suitable for dendrochronological analysis as they contained too few rings. The severely limited access to the central and west wing confirmed that this was probably true for the remainder of the roof structure. The initial assessment of the ceiling timbers had indicated that they were of a similar type (ie fast grown) though this could not be confirmed by closer inspection as they had been ceiled in or removed. Unfortunately this prevented sampling of the few

reused timbers noted during the initial assessment. Timbers removed during refurbishment were carefully examined but these again confirmed the fact that the vast majority of the material of interest in the Stables was not suitable for analysis.

The five most promising timbers in the east range were selected and sampled (Fig 16; Table 1). All others clearly contained too few rings for dating purposes. The samples were identified as above as likely to be *Pinus sylvestris* L.. Prior to measurement two of the cores were also rejected as they contained less than the acceptable minimum number of rings. No matches were found between the three measured ring sequences so all were compared to DANSON1, DANSON2, and the undated material from Danson House. Neither this nor their comparison to the available European and North American reference chronologies produced any consistent results. Thus no timbers from Danson Stables have been successfully dated.

Discussion

Danson House was the first standing building to be sampled in the conifer research project and it revealed some variation in the approach required towards a structure dominated by coniferous timber as opposed to the more routine, as far as dendrochronology in the British Isles is concerned, oak structures. The corers used by most British dendrochronologists were found to be less than ideal for the sampling of conifers because of problems with fragmentation. The corers recommended by other European colleagues were of different design and proved significantly more successful, though they required a surprisingly different approach to coring technique. Variation in the visual clues to presence of bark edge and sapwood and to conversion type, and hence which direction to sample, were also noted. The use of a microborer on the lifted floorboards was considered but on the advice of Scandinavian colleagues not pursued. The standard cores (7mm diameter) are already prone to breaking so reducing the diameter is likely to significantly increase the problems from breakage.

It is usual with oak to measure a single radius as this is considered a reliable representation of the growth pattern of the tree. However, conifer species are less reliable as they may have locally absent rings, with some sections of the trunk showing no growth or, under particularly severe conditions, some trees simply not producing a growth ring at all. With such species the measurement of several opposing radii per timber generally allows these problems to be resolved. Although this was possible with the spruce slices from Tilbury Fort (Groves 2000b) and the pine slices from Miller's House (Groves 1997b), this was clearly going to be more difficult to achieve at Danson House and Stables where sampling was heavily reliant on coring. Although it is technically feasible to take multiple core samples from individual timbers this would be undesirable in terms of aesthetic considerations and also the structural integrity may be compromised. An extensive sampling programme was the obvious

solution. Increasing the number of timbers actually sampled was considered likely to offset the anticipated problems caused by lack of duplicate radial measurements. This also had the advantage of addressing the possibilities of multiple-sourcing within a group of single phase material.

The extensive sampling programme employed certainly assisted in the identification of missing or false/shadow rings in some of the problem cores. However the percentage of dated sequences (49%) is relatively low when compared to the national success rate for oak timbers of 72% for medieval and post-medieval standing buildings (Groves 2002). Success rates for the dating of pine timbers from standing buildings elsewhere in known pine timber source regions are not available. The dating quality of the material is likely to be adversely affected by unrecognised or unresolved problems with missing/false rings, the occurrence of bands of incredibly narrow rings (Figs 17 and 18), and also the potential use of timber from multiple sources. The incidence of unresolved measurement difficulties is potentially more prevalent with core samples as opposed to slices where several radii can be measured. When sufficient material has been analysed it is hoped to compare success rates and information derived regarding use of multi-source material for sites predominantly represented by cores or slices to determine whether extensive sampling is generally of more value than smaller sampling programmes that rely on duplicate radial measurements.

One of the major concerns when initiating the conifer research project was whether it would prove possible to produce replicated chronologies from individual sites. Mixing of the material at either the point of export or import could severely hamper the successful production of chronologies by resulting in the timbers present in a single structure being from multiple diverse sources. The evidence from Tilbury Fort (Groves 2000b) and Miller's House (Groves 1997b) suggested that this may be less of a problem than anticipated. The analysis of Danson House provides further support for this theory, even though there appear to be at least three sources of timber utilised (see below).

The quality of the intra-site matching obtained appears to be comparable with that obtained for other historic conifer assemblages (Bartholin pers comm; Zunde pers comm). However as the analysis of imported conifer timbers in this country is clearly in its infancy, the reliability of the matches and the level of t values required may be reviewed as the research project progresses.

The dated site master chronologies and the dated individual ring sequence are contemporary but show little similarity, though DANSON1 and DANSON2 do crossmatch with a t value of 3.47. This lack of similarity between the ring patterns can be explained by different origins for the timbers. Although both site chronologies show good similarities with Swedish chronologies, the best matches are found between DANSON2 and a chronology from the Torun region in northern Poland, and DANSON1 and a

chronology from Dannenstern House in Riga, Latvia (Table 16). Whilst the network of Scandinavian chronologies is extensive, at present the pine chronology network available for eastern Baltic countries is rather less extensive. This fact clearly hampers provenancing through dendrochronology. However it is most likely that the timbers forming DANSON2 originated in the eastern Baltic, possibly in northern Poland or slightly further east toward Latvia (Fig 19). The initial conclusion concerning the origin of the timbers forming DANSON1 is that the timbers were probably obtained from an area around Riga. However Dannenstern House, built in AD 1696, was the house of a Riga merchant and ship builder who was particularly successful in exporting forest products to western Europe (Zunde 1998b; Zunde pers comm). Based on documentary evidence it has been concluded that the timbers for Dannenstern House most likely originated in the Dneiper basin in present day Belarus (Zunde 1998b; Zunde pers comm). Consequently it appears that the DANSON1 timbers were also likely to have originated in Belarus (Fig 20). Timber **55** matches particularly well with chronologies from central-west Sweden/Norway which suggests that the source of the timber is likely to be within this region (Fig 21; Table 16). In addition **55** also matches with some spruce chronologies from Norway and Sweden.

The lack of bark edge on the timbers, most likely due to trimming during conversion, means that although the dendrochronology results support the detailed documentary dating evidence they are unable to refine it. However even if bark edge had been widespread it would still be necessary to take into account the fact that these are imported timbers transported over long distances. If sites can be found with widespread presence of bark edge, any variation in felling date will be of potential interest. A single source group of material associated with a single construction phase would be anticipated to have no felling date variation. Variation in bark edge date may also reflect variation in source, though may not reflect different construction phases. So what of the lag between felling and actual use? The only similar group of dendrochronological material available for comparison is that of Baltic oak imports. Here it is generally thought that usage takes place as little as a few months after felling and certainly within a handful of years even allowing for the seasoning of panels (Fletcher 1980; Lavier and Lambert 1996; Tyers 2000; Simpson pers comm). There is no reason to believe that the conifer imports will be significantly different from the Baltic oak counterparts but once bark edge dates are produced from conifer assemblages this will clearly have to be monitored. The clarification of the time between felling and usage may well rely on the analysis of very well documented buildings, such as Danson House, which should therefore play an important role in the conifer research project.

The wide range of dates of the outermost rings is quite wide spanning over 125 years (Fig 22). However this can perhaps be expected as these pines are generally long lived and the growth trend in

pinus is much more marked with the growth rate slowing down significantly. The majority of the average ring widths vary between 0.6–1.3 mm, though the growth trend means that the outermost rings are frequently narrower than this. Documentary evidence suggests that the timbers undergo initial conversion at the export point with planks, boards, and baulks being referred to in documentary sources. Planks and boards may well be used as they are but baulks could be either used whole as major structural timbers or converted into timbers suitable for lesser structural elements such as partitioning. The trimming of 50mm would result in the loss of at least 45-85 rings and if it is perfectly feasible that the smaller structural elements may represent only the inner or outer sections of a larger baulk.

DANSON1 contains timbers associated with the primary construction phase and with the outermost measured ring dating to AD 1758 is consistent with a construction date of in the mid AD 1760s. The same-tree groups provide a link between different partitions as well as one of the partitions and a major crossbeam. This, combined with the successful crossmatching of a wide range of structural elements (Fig 23) suggests the use of a coherent single source group of material for the bulk of the primary construction. DANSON2 appears to include only timbers associated with the raising of the bays and, with the outermost measured ring dating to AD 1767, is consistent with a mid AD 1770s date for this modification.

The Belarus timber appears to be the dominant group of material in the primary construction phase, but timber **55** shows that this does not exclude the possibility of material from other sources being present. This could imply that the bulk of the material was purchased from a single shipment that was then augmented by other smaller purchases. Timber **55** appears to have been derived from central-west Sweden/Norway, an area noted for export of deals (boards) rather than baulks. It is possible, though clearly based on the dating of only one roofboard, that at least two sources of timber were used in the primary construction of Danson House with the large baulks from Belarus being used for major structural elements, wall-framing, and rafters, whilst deals from Scandinavia were employed for roofboarding. This is clearly a point worth considering in future sampling in other buildings.

Although the failure to obtain a wide range of samples from the Stables is clearly an opportunity lost, the data loss may not be of as great significance as was initially thought. If the number of timbers rejected in the east range was an accurate reflection of the dendrochronological quality of timber from the rest of the roof, then it would have probably proved difficult to obtain many samples with even reasonable dating potential. This difference in quality of timber used in the stables compared with that in the house implies a different source for the timbers. It therefore seems unlikely, though not proven dendrochronologically, that the timbers from this roof were reused from the original AD 1760s

stables. It seems most likely that these timbers are primary and relate to either the initial construction of the new stables in AD 1802-4 or the refurbishment in AD 1863. During the nineteenth century there was a large increase in the importation of timber from North America. The identification of the cores from the stables doesn't help determine whether they are of European or North American origin. Although there is an extensive network of North American chronologies many of these are from analyses of living trees and thus the chronological network for earlier material is somewhat less extensive. Detailed documentary work would be of great value in revealing likely source areas within North America to aid the dendrochronological analysis of imported timber of potential North American origin.

Conclusion

The study has been remarkably successful with regard to its principal aims. It has also been remarkably successful as far as the overall objectives of the English Heritage funded research project on the dendrochronological analysis of conifers designed to extend the scope of British dendrochronology.

The wood type was determined for timbers from both Danson House and Stables with all timbers likely to be *Pinus sylvestris* L. (Scots pine). Dendrochronological dates were successfully obtained for various timbers from Danson House. The dendrochronological evidence broadly supports the documentary evidence for the construction and modification of Danson House, but in the absence of bark edge on any of the dated timbers it cannot provide precise dating evidence. Although this may be disappointing to some, the successful dating of the chronologies is of immense value to the conifer research project, while the evidence derived from the analysis concerning the geographical source of the timbers is even more exciting. The ability to combine this evidence with the shifting patterns of trade indicated by documentary research will be an important step forward in the understanding of the historic timber trade and, with similar work being undertaken in Scotland, it will be possible to compare the trade patterns from these two adjacent countries, one of which had native pines available.

Acknowledgements

This analysis was funded by English Heritage. I am grateful to Richard Lea, English Heritage, for providing information about the buildings. I would also like to thank Ian Tyers, Sheffield University, for his assistance on site during our first venture into the coring of conifers and his subsequent discussion and encouragement; Thomas Bartholin provided the corers; Olafur Eggertson, Terje Thun, and Maris Zunde for checking the crossdating; Gavin Simpson, Nottingham University, for unpublished information concerning the timber importation into the British Isles; Thomas Bartholin, Olafur Eggertson, Terje Thun, Sigrid Wrobel, Pentti Zetterberg, Andrzej Zielski, and Maris Zunde, all

dendrochronologists from Scandinavia and countries around the Baltic sea, for discussions and reference data. Reference data has also been obtained from the International Tree-Ring Data Bank based in Boulder, Colorado, funded by the National Geophysical Data Center (part of the World Data Center). Tim Lawrence, Kew Gardens, and Rowena Gale, wood anatomist, provided valuable advice concerning the identification of pine species.

References

- Aniol, R W, 1983 Tree-ring analysis using CATRAS, *Dendrochronologia*, **1**, 45-53
- Baillie, M G L, 1982 *Tree-Ring Dating and Archaeology*, London
- Baillie, M G L, 1984 Some thoughts on art-historical dendrochronology, *J Archaeol Sci*, **11**, 371-93
- Baillie, M G L, and Pilcher, J R, 1973 A simple crossdating program for tree-ring research, *Tree Ring Bulletin*, **33**, 7-14
- Bonde, N, and Jensen, J S, 1995 The dating of a Hanseatic cog-ship in Denmark, in *Shipsshape, Essays for Ole Crumlin-Pederson*, Roskilde, 103-22
- Bonde, N, Tyers, I, and Wazny, T, 1997 Where does the timber come from? - Dendrochronological evidence of timber trade in Northern Europe fourteenth to seventeenth century, in *Archaeological Sciences 1995: proceedings of a conference on the application of scientific methods to archaeology* (eds A Sinclair, E Slater, and J Gowlett), Oxbow Books Monograph Ser, **64**, 201-4
- Boswijk, G, 1998 A dendrochronological study of oak and pine from the raised mires of the Humberhead Levels, eastern England, unpubl PhD thesis, Sheffield University
- Bridge, M, 2000 Can dendrochronology be used to indicate the source of oak within Britain?, *Vernacular Architect*, **31**, 67-72
- Briffa, K R, Wigley, T M L, Jones, P D, Pilcher, J R, and Hughes, M K, 1986 The reconstruction of past circulation patterns over Europe using tree-ring data, final report to the Commission of European Communities, contract no CL.111.UK(H)
- Charles, F W B, and Charles, M, 1995 *Conservation of timber buildings*, London
- Clapham, A R, Tutin, T G, and Moore, D M 1989 *Flora of the British Isles*, 3rd edn, Cambridge
- Dollinger, P, 1970 *The German Hansa*, London
- Eidem, P, 1959 En grunnskala til tidfesting av trevirke fra Flesberg in Numedal, *Blyttia*, **3**, 69-85
- English Heritage, 1998 *Dendrochronology - guidelines on producing and interpreting dendrochronological dates*, London
- Evelyn J, 1729 *Silva*, 2nd edn, London
- Fedorowicz, J K, 1980 *England's Baltic trade in the early seventeenth century*, Cambridge
- Fletcher, J, 1980 Tree-ring dating of Tudor portraits, *Proc Royal Inst Great Britain*, **52**, 81-104

- Groves, C, 1997a The dating and provenancing of imported conifer timbers in England: the initiation of a research project, in *Archaeological Sciences 1995: proceedings of a conference on the application of scientific methods to archaeology* (eds A Sinclair, E Slater, and J Gowlett), Oxbow Books Monograph Series, **64**, 205-11
- Groves, C, 1997b Appendix 5. The dendrochronological analysis of timbers from Miller's House, Three Mills Lane, Bromley-by-Bow, London: Interim spot date report, in Hanson, I, Sable, K, and MacGowan, K, *The Miller's House, Three Mills Lane, Bromley by Bow: Archive and Assessment report*, Passmore Edwards unpubl rep
- Groves, C, 2000a *Tree-ring analysis of timbers from Peterborough Cathedral, Peterborough, Cambridgeshire: boards from the painted nave ceiling – phase 2*, Anc Mon Lab Rep, **37/2000**
- Groves, C, 2000b Dendrochronological analysis, in Moore, P, Tilbury Fort: a post-medieval fort and its inhabitants, *Post Medieval Archaeology*, **34**, 38-42
- Groves, C, forthcoming Dendrochronology, in *Bowhill, Exeter* (S R Blaylock), English Heritage Archaeol Monograph
- Groves, C, 2000c Belarus to Bexley and beyond: dendrochronology and dendroprovenancing of conifer timbers, *Vernacular Architect*, **31**, 59-66
- Groves, C, 2002 *Dendrochronological analysis of Bowhill, Exeter, Devon*, Centre for Archaeol Rep, **23/2002**
- Groves, C, and Boswijk, G 1998 *Tree-ring analysis of coffin boards from the former burial ground of the infirmary, Newcastle upon Tyne*, Anc Mon Lab Rep, **15/98**
- Howard, R E, Laxton, R R, Litton, C D, and Simpson, W G, 1995 List 60 – Nottingham University Tree-Ring Dating Laboratory Results: General List, *Vernacular Architect*, **26**, 47-53
- James, N D G, 1990 *A history of English Forestry*, 2nd edn, Oxford
- Kent, H S K, 1973 *War and trade in northern seas: Anglo-Scandinavian economic relations in the mid-eighteenth century*, Cambridge
- Lavier, C, and Lambert, G, 1996 Dendrochronology and works of art, in *Tree Rings, Environment and Humanity* (eds J S Dean, D M Meko, and T W Swetnam), 543-56, Arizona
- Lewis, E, 1995 A sixteenth century painted ceiling from Winchester College, *Proc Hants Field Club Archaeol Soc*, **51**, 137-65
- Mills, C, and Crone, A, 1998 Tree-ring evidence for the historic timber trade and woodland exploitation in Scotland, in *Dendrochronology and Environmental Trends* (eds V Stravinskiene and R Juknys), 46-55, Kaunas
- Munro, M A R, 1984 An improved algorithm for crossdating tree-ring series, *Tree Ring Bulletin*, **44**, 17-27
- Rackham, O, 1990 *Trees and woodland in the British Landscape*, 2nd edn, London
- Schweingruber, F H, 1990 *Anatomy of European woods*, Berne and Stuttgart

- Storsletten, O and Thun, T, 1993 Dendrochronology and the investigation of buildings, *Riksantikvarens Rapport*, **22**
- Thun, T, 1987 Comparison of tree-ring chronologies from southern Norway, *Annales Academiae Scientiarum Fennicae A III*, **145**, 89-95
- Tyers I, 1991a Tree-ring Dating. *Medieval World*, **2**, 12-18
- Tyers, I, 1991b *Dendrochronology report on building timbers and wooden panelling from Sutton House, Hackney, London*, MoLAS Dendro Rep, **02/91**
- Tyers, I, 1997 *Dendro for Windows program guide*, ARCUS Rep, **340**
- Tyers, I, 1999 *Dendro for Windows program guide*, 2nd edn ARCUS Rep, **500**
- Tyers, I, 2000 *Tree-ring analysis and wood identification on timbers excavated on the Magistrates Court Site, Kingston upon Hull, East Yorkshire*, ARCUS Rep, **410**
- Tyers, I, Hillam, J, and Groves, C, 1994 Trees and woodland in the Saxon period: the dendrochronological evidence, in *Environment and Economy in Anglo-Saxon England* (ed J Rackham), CBA Res Rep, **89**, 12-22
- Wazny, T, 1990 *Aufbau und Anwendung der Dendrochronologie für Eichenholz in Polen*, unpubl PhD thesis, Univ Hamburg
- Wheeler, E A, Pearson, R G, LaPasha, C A, Zack ,T, and Hatley, W, 1986 *Computer-Aided Wood Identification*, North Carolina State Univ
- Zetterberg, P, 1988 Appendix 2 – Dendrochronology and archaeology: dating of a wooden causeway in Renko, southern Finland, *Fennoscandia Archaeologica*, **5**, 92-103
- Zetterberg, P and Hiekkanen, M, 1990 Dendrochronological studies on the age and construction phases of the medieval stone church of Sipoo (Sibbo), southern Finland, in *Finska Fornminnesforeningen*, **97**, 87-98
- Zunde, M, 1998a Wood export from medieval Riga and possibilities for dendrochronological dating, in *Dendrochronology and Environmental Trends* (eds V Stravinskiene and R Juknys), 67-74, Kaunas
- Zunde, M, 1998b Dendrochronological and historical dating of the Dannenstern House and an eighteenth century revetment along the River Daugava, *Sena Riga*, 315-332
- Zunde, M 1998/9 Timber export from old Riga and its impact on dendrochronological dating in Europe, *Dendrochronologia*, **16/17**, 119-130

Table 1: Details of the samples from Danson House and Stables

Phase – 1 = house: primary build; 2 = house: raising of the bays; ? = timbers of unknown function

Rings - total number of measured rings

n + or + *n* - unmeasured inner rings or unmeasured outer rings

Sapwood – number of sapwood rings; hs = heartwood/sapwood boundary

AGR - average growth rate in millimetres per year

Cross-section dimensions – maximum dimensions of the cross-section in millimetres

Sample	Level	Function	Phase	Rings	Sapwood	AGR	Cross-section dimensions	Date of measured ring sequence	Comment
<u>House</u>									
1	attic	dome support	1	77	-	1.61			core
2	attic	dome support	1	67	-	1.64			core
3	attic	rafter	1	138	-	1.02		AD1504-1641	core
4	bedroom	stairs	1	116+35	hs+35	1.32		AD1559-1674	core
5	attic	valley rafter	1	72/59	-				core; unmeasurable band so sequence measured in two sections
6	attic	rafter	1	98	-	0.87		AD1540-1637	core
7	bedroom	partition C	1	137	-	1.00			core; 'same-tree' as 8, 17, 19, and 22
8	bedroom	partition C	1	134	60	1.02			core; 'same-tree' as 7, 17, 19, and 22
9	bedroom	west room N-S beam	1	119	-	1.35		AD1568-1686	core
10	bedroom	west room E-W beam	1	103	-	1.35		AD1594-1696	core
11	bedroom	partition D	1	153	-	0.60	150 x 105	AD1521-1673	core; 'same-tree' as 12, 14, and 27
12	bedroom	partition D	1	249	56	0.61	150 x 110	AD1510-1758	core; 'same-tree' as 11, 14, and 27
13	bedroom	partition D	1	94	-	1.99	150 x 145		core
14	bedroom	partition D	1	179	12	0.69	155 x 95	AD1523-1701	core; 'same-tree' as 11, 12, and 27
15	bedroom	partition D	1	4+177	50	1.01	280 x 150	AD1552-1728	core; 'same-tree' as 43
16	bedroom	partition D	1	103	-	1.26	150 x 140		core
17	bedroom	partition D	1	110	-	1.20	150 x 70		core; 'same-tree' as 7, 8, 19, and 22
18	bedroom	stair support	1	202	25	0.83	205 x 125	AD1497-1698	core
19	bedroom	partition D	1	93	-	1.29	150 x 70		core; 'same-tree' as 7, 8, 17, and 22
20	bedroom	partition D	1	89	-	0.67	150 x 70		core; 'same-tree' as 24
21	bedroom	partition D	1	105	-	1.19	150 x 100	AD1588-1692	core

Table 1 (cont)

Sample	Level	Function	Phase	Rings	Sapwood	AGR	Cross-section dimensions	Date of measured ring sequence	Comment
22	bedroom	partition D	1	106	-	1.23	150 x 70		core; 'same-tree' as 7, 8, 17, and 19
23	bedroom	partition C	1	134	-	1.16	270 x 135	AD1521-1654	core
24	bedroom	partition C	1	55	-	0.76	140 x 60		core; 'same-tree' as 20
25	bedroom	partition C	1	228	?hs	0.79	140 x 130		core; 'same-tree' as 26, 28, and 50
26	bedroom	partition C	1	202	?hs	0.67	135 x 125		core; 'same-tree' as 25, 28, and 50
27	bedroom	partition E	1	209	-	0.58	145 x 90	AD1523-1731	core; 'same-tree' as 11, 12, and 14
28	bedroom	partition E	1	+186	-	0.54	155 x 150		core; 'same-tree' as 25, 26, and 50
29	bedroom	partition E	1	176	28	0.74	210 x 140		core
30	bedroom	partition E	1	79	-	2.41	155 x 155		core
31	bedroom	partition E	1	107	-	1.14	150 x 95	AD1583-1689	core
32	bedroom	partition F	1	97	13	1.10	215 x 150		core
33	bedroom	partition F	1	84	-	1.88	200 x 145		core; 'same-tree' as 35
34	bedroom	partition F	1	129	-	1.39	155 x 130	AD1507-1635	core; 'same-tree' as 36
35	bedroom	partition F	1	95	-	1.94	200 x 155		core; 'same-tree' as 33
36	bedroom	partition F	1	129	-	1.24	150 x 125	AD1518-1646	core; 'same-tree' as 34
37	bedroom	east bay E-W beam	2	111	-	1.61	355 x 155		core
38	bedroom	east room E-W beam	1	173	-	0.75	295 x 285	AD1501-1673	core
39	bedroom	east room N-S beam	1	199	66	0.92	300 x 270	AD1528-1726	core
40	bedroom	east bay NE-SW stub	2	160	-	1.23	240 x 125	AD1572-1731	core; 'same-tree' as 41
41	bedroom	east bay NW-SE stub	2	192	74	0.91	220 x 115	AD1576-1767	core; 'same-tree' as 40
42	bedroom	south room N-S beam	1	+120	-	0.79	295 x 290	AD1556-1675	core
43	bedroom	south room N-S beam	1	118	-	0.96	290 x 280	AD1560-1677	core; 'same-tree' as 15
44	bedroom	north room N-S beam	1	155	20	0.96	295 x 285	AD1556-1710	core
45	bedroom	west room N-S beam	1	80	-	2.07	300 x 280		core
46	bedroom	west room E-W beam	1	123	-	1.57	290 x 280	AD1554-1676	core
47	principal	west room N-S beam	1	114	-	1.26	300 x ?	AD1529-1642	core
48	<i>ex situ</i>	floor joist	1	117	-	1.50	320 x 75	AD1512-1628	core
49	bedroom	partition B	1	124	44	0.79	155 x 125	AD1607-1730	core
50	bedroom	partition A	1	+180	?hs	0.63	200 x 150		core; 'same-tree' as 25, 26, and 28

Table 1 (cont)

Sample	Level	Function	Phase	Rings	Sapwood	AGR	Cross-section dimensions	Date of measured ring sequence	Comment
51	<i>ex situ</i>	roof truss	1	187+2	-	0.85	140 x 130	AD1489-1675	slice
52	<i>ex situ</i>	partition diagonal strut	1	130+5	-	0.95	115 x 110		slice; bedroom level?
53	<i>ex situ</i>	floor joist	1	111/76	-	0.78	150 x 65		slice; principal or bedroom level bay; unmeasurable band so sequence measured in two sections
54	<i>ex situ</i>	unknown	?	143	-	1.02	145 x 60	AD1508-1650	slice
55	<i>ex situ</i>	roof board	1	212	?hs	0.54	225 x 25	AD1494-1705	slice; roof valley?
56	<i>ex situ</i>	unknown	?	60	9	3.61	220 x 185		slice
57	<i>ex situ</i>	unknown	?	82	30	2.00	200 x 65		slice
58	<i>ex situ</i>	unknown	?	103+3	48+3	1.51	200 x 75		slice; 'same-tree' as 61
59	<i>ex situ</i>	partition horizontal	1	166+6	38+6	0.90	150 x 95	AD1579-1744	slice; attic level north side partition?
60	<i>ex situ</i>	wall plate	1	114+5	27+5	1.71	215 x 140		slice
61	<i>ex situ</i>	trussed girder side bay	1	94+10	24+10	1.55	190 x 70		slice; section of longer timber; 'same-tree' as 58
62	<i>ex situ</i>	unknown	?	159	9	1.09	195 x 125		slice
63	<i>ex situ</i>	wall plate east bay	2	135+3	7+3	1.43	170 x 125	AD1567-1701	slice; ?section facing south-east
64	<i>ex situ</i>	wall plate	2	81	-	2.06	155 x 135	AD1545-1625	slice; ?raised bay
65	<i>ex situ</i>	trussed girder side bay	1	116	53	1.49	320 x 160		slice; section of longer timber; 'same-tree' as 58 and 61
66	<i>ex situ</i>	trussed girder side bay	1	83	-	2.36	180 x 140		slice; section of longer timber
67	<i>ex situ</i>	trussed girder side bay	1	11+115	-	1.58	175 x 100	AD1532-1646	slice; section of longer timber
68	<i>ex situ</i>	floor joist	1	75	-	2.57	315 x 260		slice; ?attic level west bay
69	<i>ex situ</i>	floorboard	1	69	-	1.14	175 x 35		slice
<u>Stables</u>									
70	east wing	truss 2 king post	-	62	11	2.17	335 x 130		core
71	east wing	truss 2 tiebeam	-	26	-	3.08	215 x 150		core
72	east wing	truss 3 king post	-	44	26	3.34	300 x 110		core
73	east wing	truss 3 tiebeam	-	103	42	1.30	200 x 110		core
74	east wing	truss 4 king post	-	61	-	2.02	270 x 110		core

Table 2: Matrix showing the t values obtained between the matching ring sequences included in DANSON1. - = t values less than 3.00; numbers in red highlight those t values over 10 suggesting possible 'same tree' groups

	6	9	11	12	14	15	18	21	23	27	31	34	36	38	42	43	44	46	47	48	51	54	67
3	5.96	-	-	5.00	3.57	-	-	4.99	4.02	3.48	3.86	-	-	5.41	4.56	-	-	4.02	4.53	5.97	3.13	3.18	-
6		-	3.71	3.47	4.22	3.79	4.01	6.97	4.90	4.69	7.07	3.13	4.28	3.94	4.45	-	3.60	4.52	6.09	4.60	3.36	3.70	-
9			3.50	3.84	3.81	5.02	4.20	3.08	-	5.06	-	-	4.86	3.51	-	3.13	-	3.66	-	-	4.31	-	4.30
11				8.71	10.82	3.97	4.43	-	-	9.83	-	5.28	6.42	-	3.58	3.38	3.95	3.92	4.67	4.26	-	4.85	3.41
12					13.00	3.98	4.20	3.99	4.02	17.48	3.32	6.89	5.21	4.51	3.21	-	-	3.34	3.82	4.80	5.89	3.91	3.23
14						5.49	5.18	-	4.30	13.46	-	5.26	4.11	4.78	3.60	4.07	5.75	3.70	4.86	5.65	3.86	5.16	4.43
15							-	-	4.19	3.62	-	3.28	4.45	3.01	3.94	10.38	4.67	-	-	-	4.07	3.71	5.86
18								-	-	3.86	-	4.17	3.56	3.16	4.90	3.05	-	4.40	-	-	4.08	4.59	-
21									4.61	-	9.57	-	3.35	-	3.66	-	-	3.50	4.36	3.84	4.88	-	-
23										4.85	3.16	-	3.32	-	6.64	-	3.11	5.15	-	4.48	-	3.45	3.08
27											3.09	4.59	3.56	5.07	3.17	-	3.17	4.92	3.84	6.99	4.10	3.81	4.16
31												-	3.11	-	3.38	-	-	3.84	4.69	3.48	4.39	3.27	-
34													10.63	3.91	-	3.23	-	-	3.93	4.02	3.29	5.77	-
36														3.31	4.95	3.58	-	-	4.10	3.14	4.02	6.28	3.68
38															3.18	-	-	4.74	-	5.72	3.08	3.99	-
42																3.23	3.99	-	3.49	4.03	3.65	3.10	3.05
43																	3.89	-	-	-	3.20	3.47	3.52
44																		-	3.49	-	3.83	-	-
46																			3.17	5.10	3.15	-	3.19
47																				3.46	3.02	-	-
48																					-	5.83	3.75
51																						-	-
54																							5.63

Table 3: The ring width data from the site master chronology, DANSON1, dated AD 1489-1758 inclusive

Date	Ring widths (units of 0.01mm)									
AD1489	396	356	353	266	310	310	402	467	476	463
								446	358	
AD1501	333	311	338	298	287	316	263	217	208	215
	179	214	197	164	199	211	188	175	191	167
	160	154	126	116	140	143	132	119	129	117
	116	132	121	177	186	183	168	153	138	122
	143	145	156	165	149	151	154	161	133	146
AD1551	128	127	121	127	160	168	124	130	189	181
	199	182	150	152	122	160	182	164	158	159
	150	141	128	132	130	159	148	128	142	142
	134	114	135	122	127	121	106	126	118	109
	102	125	109	128	127	122	94	111	83	100
AD1601	75	110	95	93	76	79	93	92	89	84
	103	85	75	93	87	102	115	80	66	92
	71	70	83	73	77	80	77	72	66	75
	75	75	79	73	80	75	86	76	73	98
	80	72	53	62	64	67	63	64	63	67
AD1651	69	58	62	67	69	91	59	51	47	48
-	48	49	57	68	62	64	64	63	58	61
-	56	53	50	50	54	63	58	66	68	69
-	88	83	75	87	66	93	90	67	51	40
-	46	46	45	58	55	43	54	55	70	74
AD1701	68	77	73	104	80	59	65	57	55	48
-	42	49	52	58	44	48	50	66	51	59
-	64	59	79	70	63	52	70	89	67	64
-	43	52	37	40	27	28	27	33	30	33
-	35	41	41	41	44	51	29	16	20	32
AD1751	41	48	57	95	138	82	55	30		

Table 4: Matrix showing the t values obtained between the ring sequences from a group of matching samples; numbers in red highlight those t values over 10 suggesting possible 'same tree' groups

	41	63	64
40	16.88	8.87	6.33
41		8.09	7.21
63			3.24

Table 5: The ring width data from the site master chronology, DANSON2, dated AD 1545-1767 inclusive

Date	Ring widths (units of 0.01mm)									
AD1545					311	340	293	393	341	333
AD1551	280	286	302	247	288	274	224	219	238	318
	313	327	260	192	182	173	238	220	212	295
	289	244	238	261	240	268	337	290	330	307
	289	315	333	337	320	332	245	263	198	195
	198	197	204	207	196	251	206	251	170	186
AD1601	173	192	133	183	193	136	184	160	146	146
	204	138	128	128	109	98	130	126	124	152
	102	130	142	90	134	115	137	148	92	125
	69	109	121	88	117	100	79	92	99	75
	76	79	70	68	110	88	104	73	78	103
AD1651	122	83	86	54	82	102	79	100	61	69
	80	93	77	74	63	56	45	82	72	56
	40	51	35	28	46	48	48	57	39	71
	56	75	58	62	54	83	77	68	61	49
	61	76	55	53	44	37	48	40	42	38
AD1701	49	57	47	68	66	55	52	47	41	55
	44	44	42	47	32	46	44	53	34	30
	37	45	49	42	22	17	24	26	31	41
	41	47	35	48	35	33	36	36	35	46
	45	42	42	33	32	43	36	29	19	18
AD1751	28	32	41	21	26	47	40	26	51	24
	38	31	47	60	97	101	133			

Table 6: Matrix showing the t values obtained between the ring sequences from a group of matching samples; numbers in red highlight those t values over 10 suggesting possible 'same tree' groups

	08	17	19	22
07	29.64	10.37	18.32	10.17
08		11.22	17.27	11.65
17			12.13	23.88
19				12.15

Table 7: Matrix showing the t values obtained between the ring sequences from a group of matching samples; numbers in red highlight those t values over 10 suggesting possible 'same tree' groups

	26	28	50
25	18.07	11.54	12.60
26		12.92	11.83
28			13.03

Table 8: Matrix showing the t values obtained between the ring sequences from a group of matching samples; numbers in **red** highlight those t values over 10 suggesting possible ‘same tree’ groups

	61	65
58	10.32	7.00
61		6.29

Table 9: Matrix showing the t values obtained between the ring sequences from a matching pair of samples

	24
20	7.09

Table 10: Matrix showing the t values obtained between the ring sequences from a pair of matching samples’; numbers in **red** highlight those t values over 10 suggesting possible ‘same tree’ groups

	35
33	10.31

Table 11: The ring width data from the undated site master chronology, DANSON3

Ring widths (units of 0.01mm)									
305	253	308	261	243	217	236	157	148	151
130	138	115	139	144	147	130	103	95	142
139	136	147	97	102	93	83	121	144	128
157	112	187	130	156	158	140	142	162	168
187	194	230	194	199	155	203	214	233	226
174	151	143	119	104	119	136	137	158	140
127	112	153	142	127	132	146	178	183	36
11	8	13	12	16	19	25	37	38	44
51	64	82	83	87	117	139	92	156	161
119	106	74	105	94	80	79	80	110	91
91	86	59	50	78	59	84	115	105	137
126	89	61	70	85	47	44	44	45	45
53	64	77	74	74	87	81	79	62	59
48	61	73	73	79	75	83	91	72	73
94	88	44	27	36	45	34	38	56	59
77	71	60	47	54	52	49	67	78	54
46									

Table 12: The ring width data from the undated site master chronology, DANSON4

Ring widths (units of 0.01mm)									
354	261	204	198	202	199	227	172	195	187
146	130	17	29	28	24	24	20	26	32
55	56	73	58	61	67	85	76	78	80
58	69	76	73	86	98	90	70	68	85
65	73	70	76	90	98	75	70	78	68
49	15	14	12	14	20	23	27	25	32
30	33	30	36	38	40	45	44	62	44
51	56	56	61	77	67	64	84	67	78
74	69	56	48	71	84	78	63	80	81
83	69	73	73	80	69	65	74	89	23
18	21	22	24	27	27	28	30	33	28
32	28	34	36	40	50	59	54	63	57
65	49	49	63	74	74	92	86	71	89
72	65	79	98	85	83	93	70	76	73
81	92	70	90	82	75	89	64	95	71
83	93	84	93	76	83	84	93	110	105
83	76	95	104	95	87	89	83	86	71
58	82	71	70	85	73	72	67	62	62
73	68	68	72	71	68	78	69	71	71
73	72	68	67	77	66	65	60	60	68
69	61	77	68	88	97	77	68	67	82
69	54	65	60	59	55	46	51	45	54
53	43	51	60	53	62	60	52	46	37
44	46								

Table 13: The ring width data from the undated site master chronology, DANSON5

Ring widths (units of 0.01mm)									
276	345	347	359	356	371	330	340	221	263
262	291	263	250	239	234	222	208	281	285
257	249	237	245	210	175	211	235	219	269
225	231	181	183	165	155	138	136	153	123
138	176	131	170	202	216	201	157	127	159
132	196	147	99	134	116	78	69	43	57
80	84	47	78	107	93	111	134	144	161
168	116	148	147	123	109	91	91	102	127
100	71	132	127	95	90	101	93	93	101
80	72	98	126	113	119	129	127	121	116
88	101	126	112	80	53	68	69	60	47
59	92	63	51	36	65				

Table 14: The ring width data from the undated site master chronology, DANSON6

Ring widths (units of 0.01mm)									
78	77	71	76	83	86	105	113	106	99
104	77	71	62	62	59	66	54	57	49
59	77	55	62	94	94	101	90	42	34
40	43	40	41	45	60	56	35	43	40
52	70	92	92	102	99	85	62	77	64
79	109	104	91	107	67	74	66	47	57
67	84	68	55	63	58	46	66	64	92
81	62	50	60	58	77	76	85	71	55
75	54	48	68	60	41	60	57	74	

Table 15: The ring width data from the undated site master chronology, DANSON7

Ring widths (units of 0.01mm)									
308	309	300	309	371	294	352	360	329	415
399	382	369	354	400	299	301	284	257	256
331	325	268	321	352	318	254	210	238	278
209	201	203	178	184	192	172	236	197	182
238	208	188	181	162	166	150	160	151	145
156	140	154	124	112	117	147	120	114	122
116	129	133	128	116	140	123	80	119	110
120	135	88	88	95	98	76	68	100	95
84	83	56	63	75	91	73	51	69	89
83	116	101	112	107	136	136	89	98	

Table 16: Dating the site master chronologies, DANSON1 and DANSON2, and the individual ring sequence from 55. Results of comparisons between some relevant pine reference chronologies; * - *t* values provided by Eggertson on CATRAS (Aniol 1983). Some *t* values less than 3.0 are given to demonstrate why it is thought that the timbers are imported from particular regions; - = *t* values not known but less than 3.50

Region/Group	Reference chronology	<i>t</i> value		
		DANSON1	DANSON2	55
Finland	South (Zetterberg 1988)	3.21	2.84	0.04
Latvia(?Belarus)	Dannenstern House, Riga (Zunde 1998b)	14.70	5.93	0.33
Norway	Grunnskala Flesberg (Eidem 1959)	2.51	1.69	3.06
	Hovden (Thun 1987)	0.11	0.74	5.43
	Hurdal (Briffa <i>et al</i> 1986)	1.22	0.20	0.64
	Jondalen (Briffa <i>et al</i> 1986)	1.24	0.21	1.32
	Jonsvannet (Thun pers comm)	1.38	0.94	1.90
	Visdalen (Briffa <i>et al</i> 1986)	0.00	0.32	3.14
Poland	Northern central – Torun region (Zielski pers comm)	4.42	6.95	0.09
Sweden	Aaland (Bartholin pers comm)	3.32	2.85	0.00
	Dalarna (Bartholin pers comm)	3.70	1.31	4.02
	Gotland (Bartholin pers comm)	5.45	6.16	0.00
	Gravsten (Bartholin pers comm)	5.59	3.87	0.00
	Gtaland (Bartholin pers comm)	1.10	2.77	0.08
	Helsingland (Bartholin pers comm)	2.88	0.00	4.16
	Hrjedalen (Bartholin pers comm)	2.53	0.00	10.19
	Jaemtland (Bartholin pers comm)	2.48	0.00	7.47
	Ostergotaland (Eggertson pers comm)*	6.70	5.58	-
	Smaland (Eggertson pers comm)*	5.80	4.77	-
	Stockholm (Bartholin pers comm)	7.41	4.30	1.43
	Uppland (Bartholin pers comm)	4.84	1.43	2.73

Figure 1: Plan showing the location of Danson House and Danson Stables,

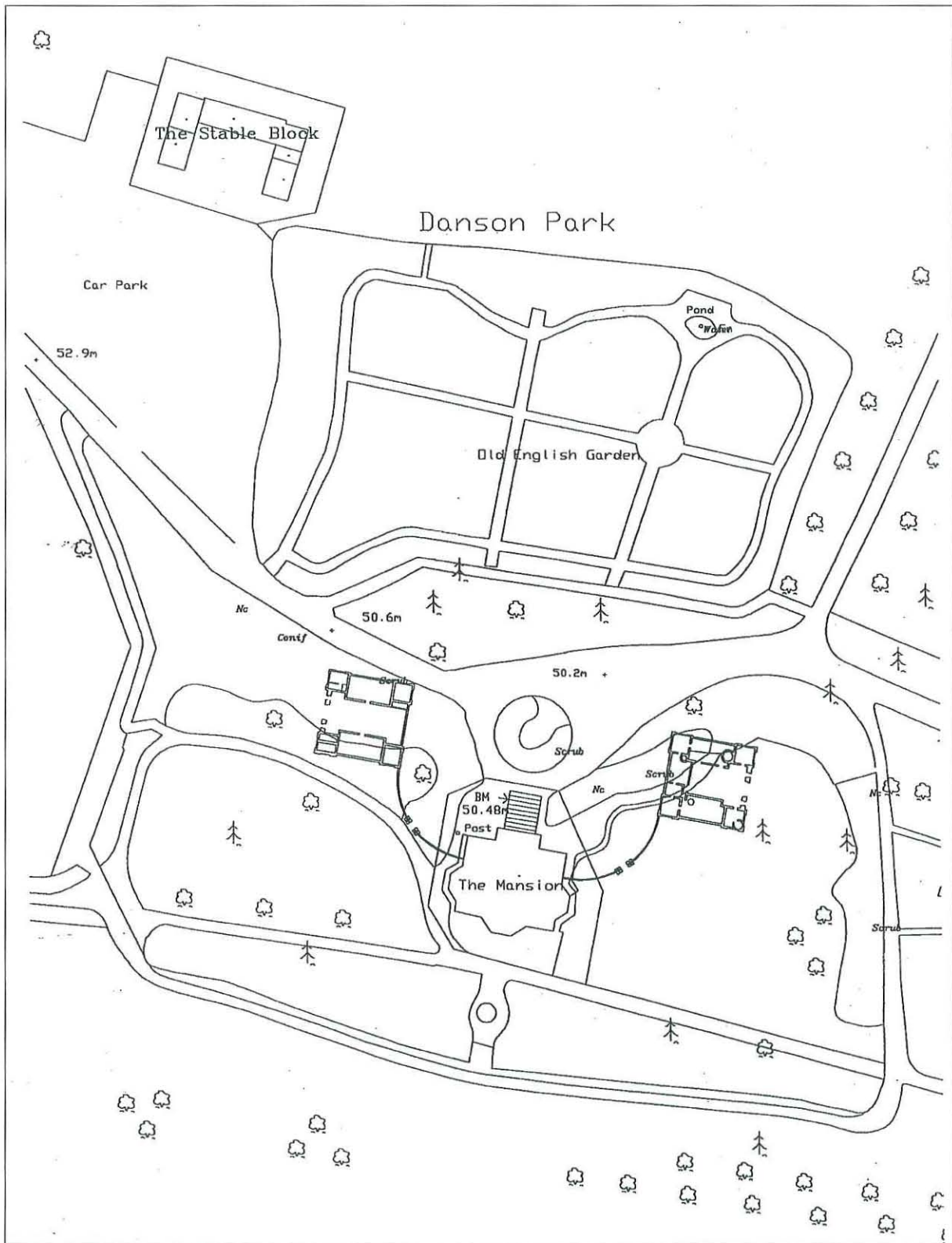

Figure 2: Photograph of Danson House viewed from the north during restoration (English Heritage Photographic Library)



Figure 3: Photograph of Danson Stables viewed from the south during restoration (English Heritage Photographic Library)

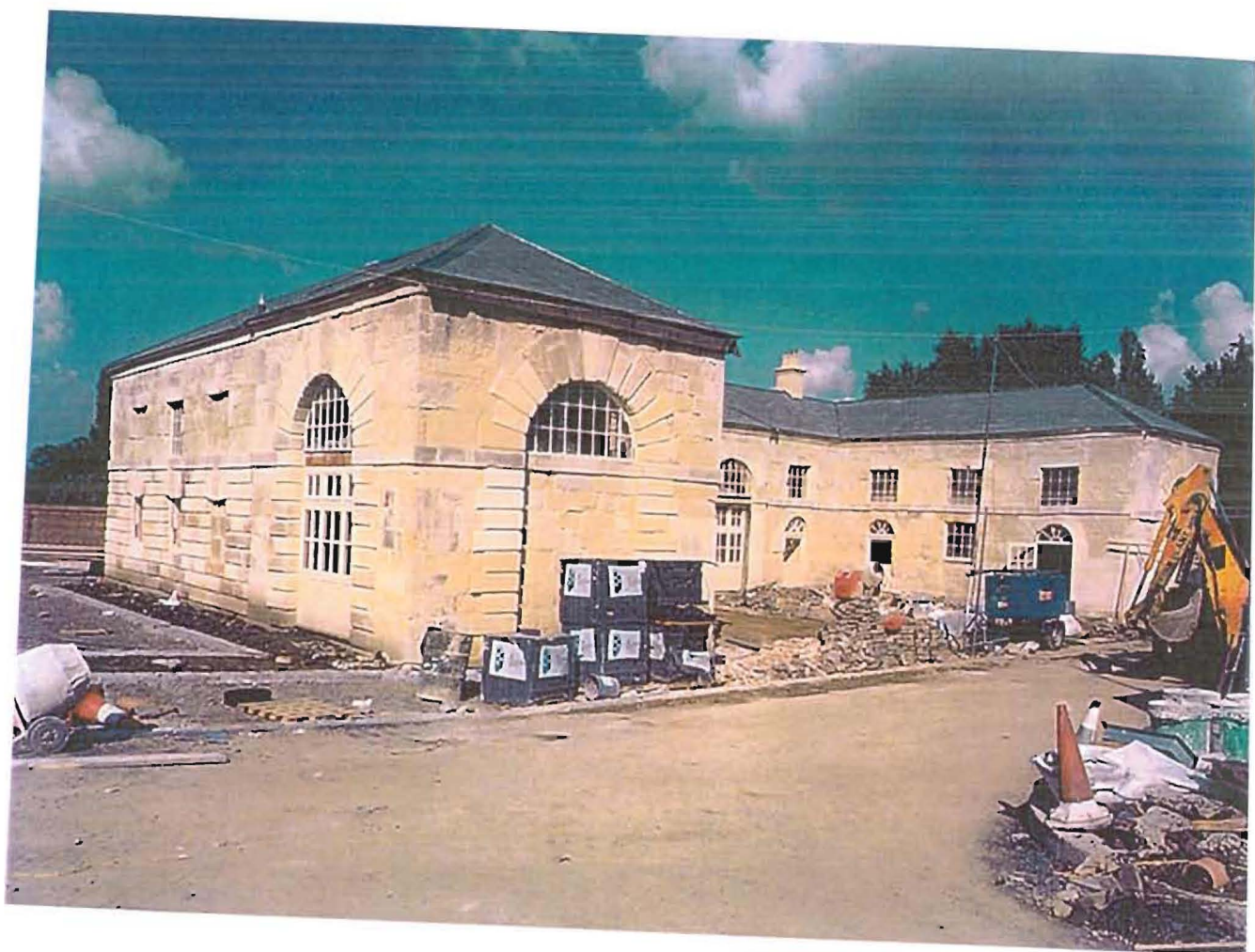

Figure 4: Plan of bedroom level floor (after Purcell, Miller, Tritton, and Partners 1994) showing the location of the partitions (C, D, E, and F) and the other sampled timbers. Dated timbers or partitions with dated elements are indicated in red

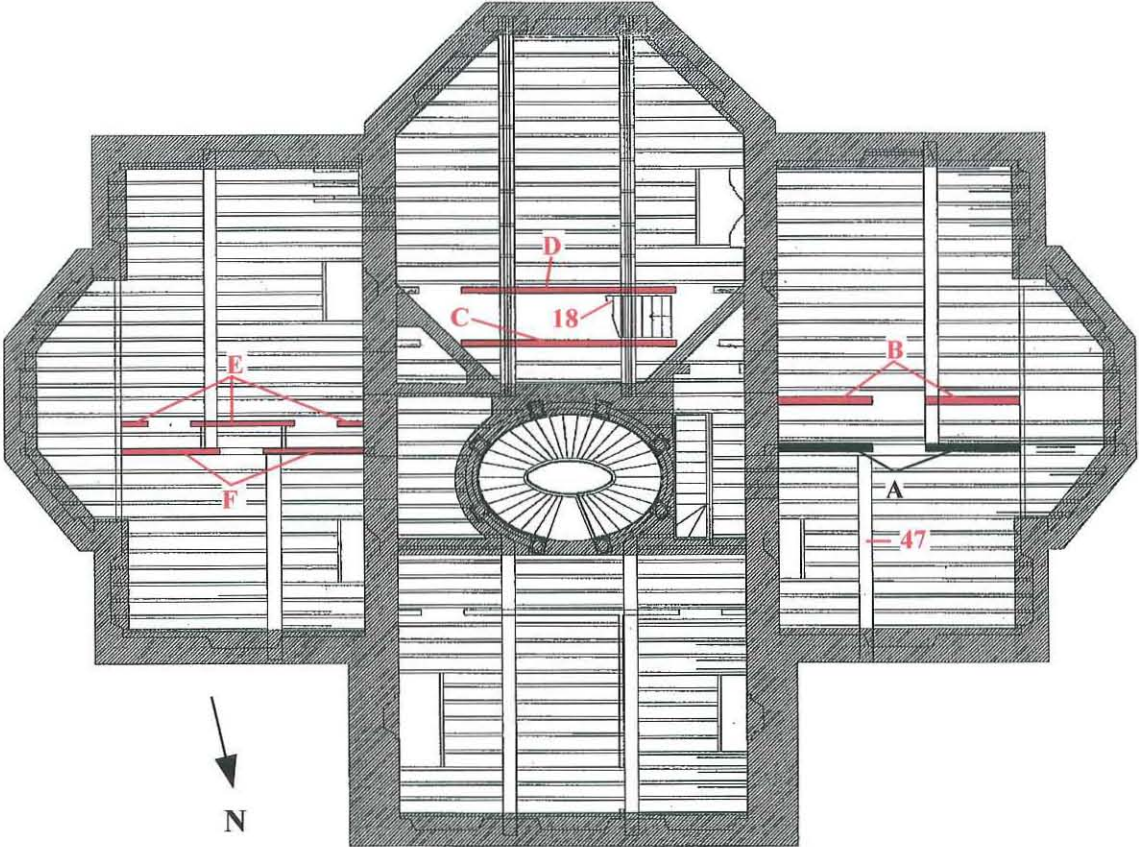

Figure 5: Plan of attic level floor (after Purcell, Miller, Tritton, and Partners 1994, Lea pers comm) showing the location of the sampled timbers. Dated timbers are indicated in red

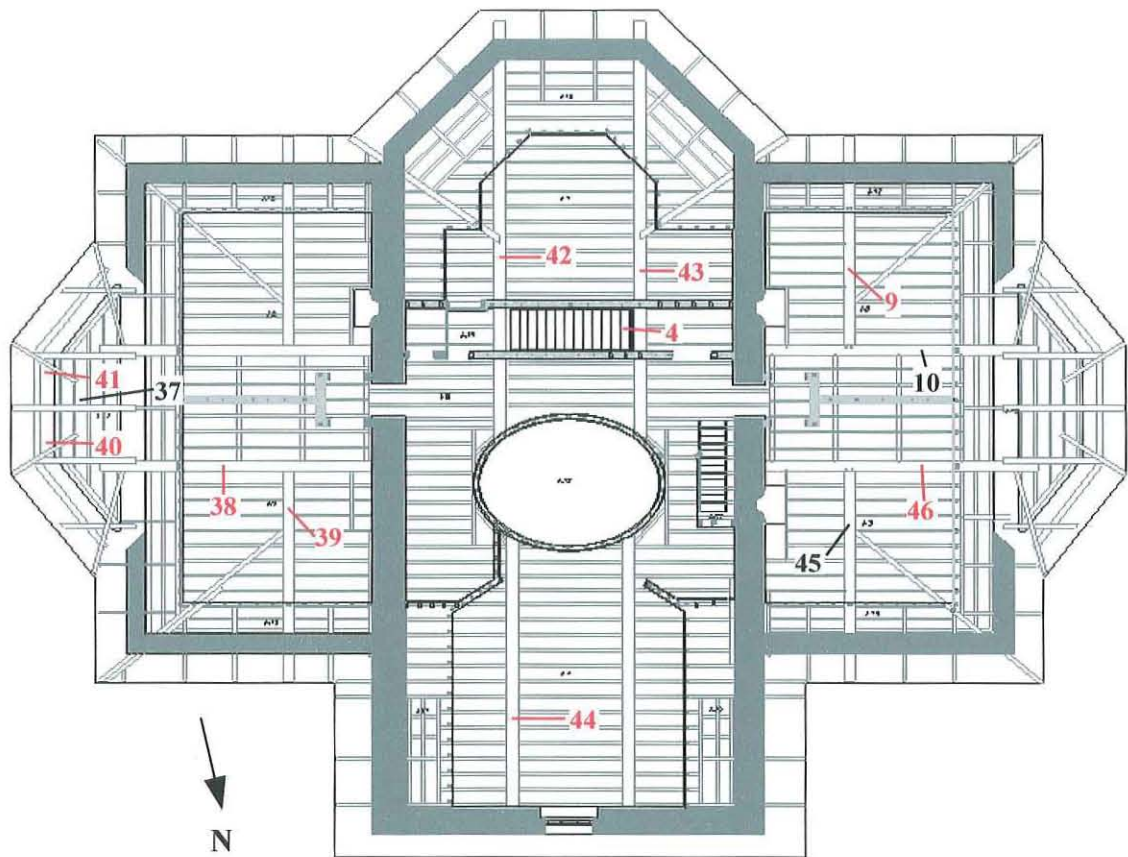

Figure 6: Plan of the roof (after Purcell, Miller, Tritton, and Partners 1994) showing the location of the sampled timbers. Dated timbers are indicated in **red**

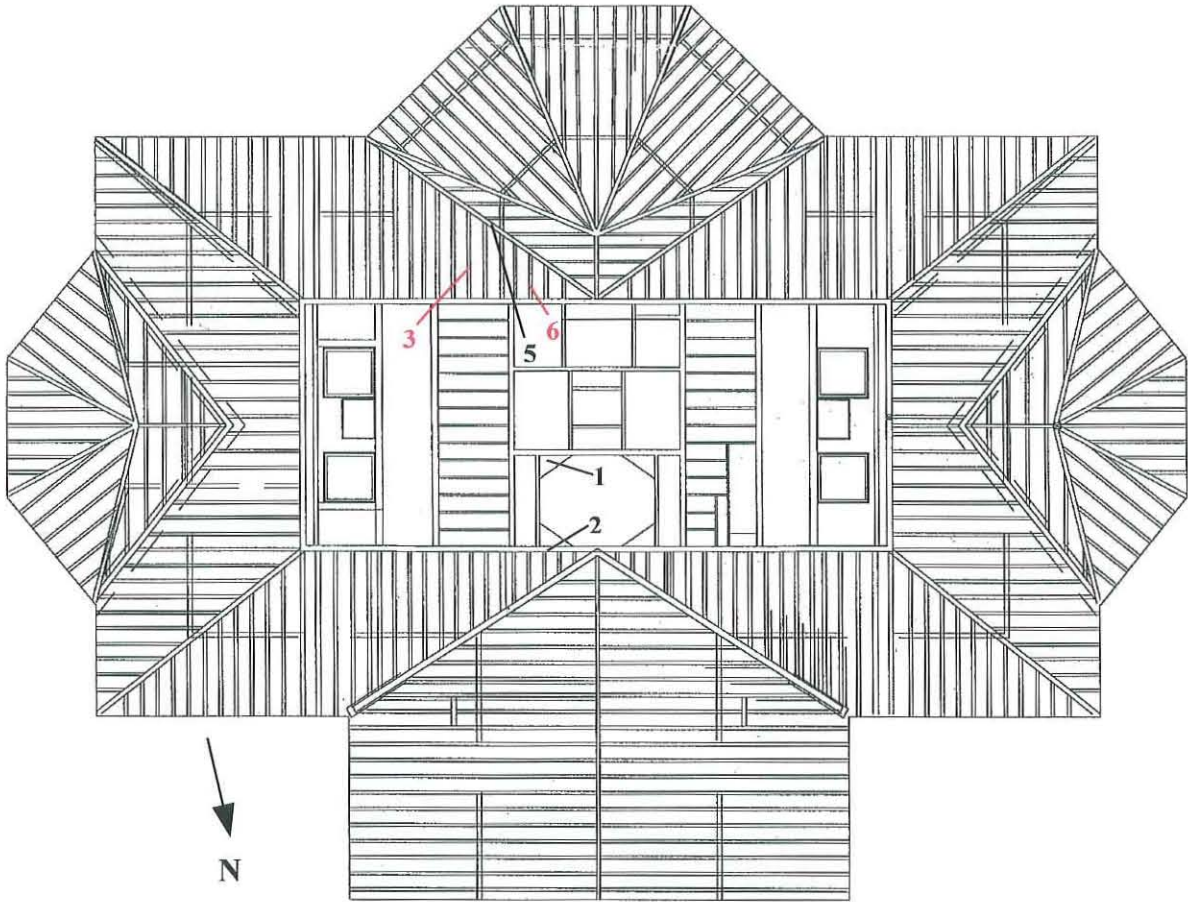

Figure 7: Schematic diagram of the north face of partition C on the bedroom level showing the location of the sampled timbers. Samples 7 and 8 were taken from the south face where some additional elements of partition C were exposed but the precise location of each element is not known. Dated timbers are indicated in **red**

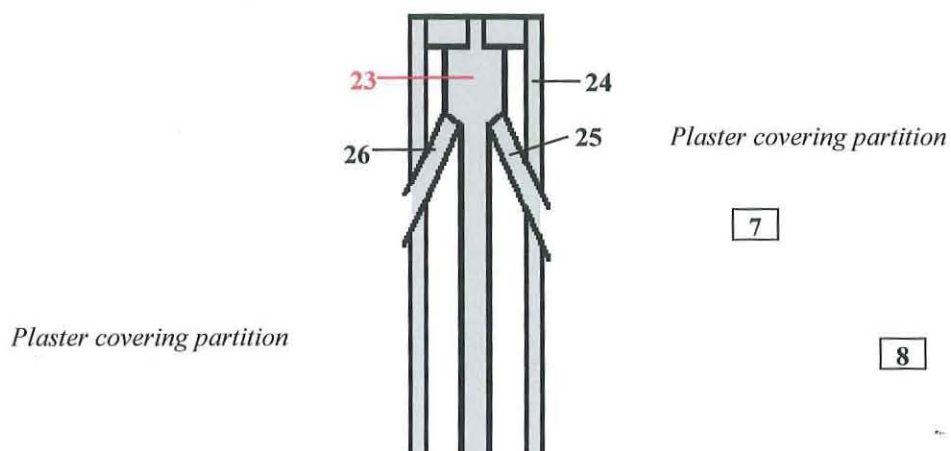

Figure 8: Photograph of south face of partition D on the bedroom level (C Groves)



Figure 9: Schematic diagram of the south face of partition D on the bedroom level showing the location of the sampled timbers. Dated timbers are indicated in **red**

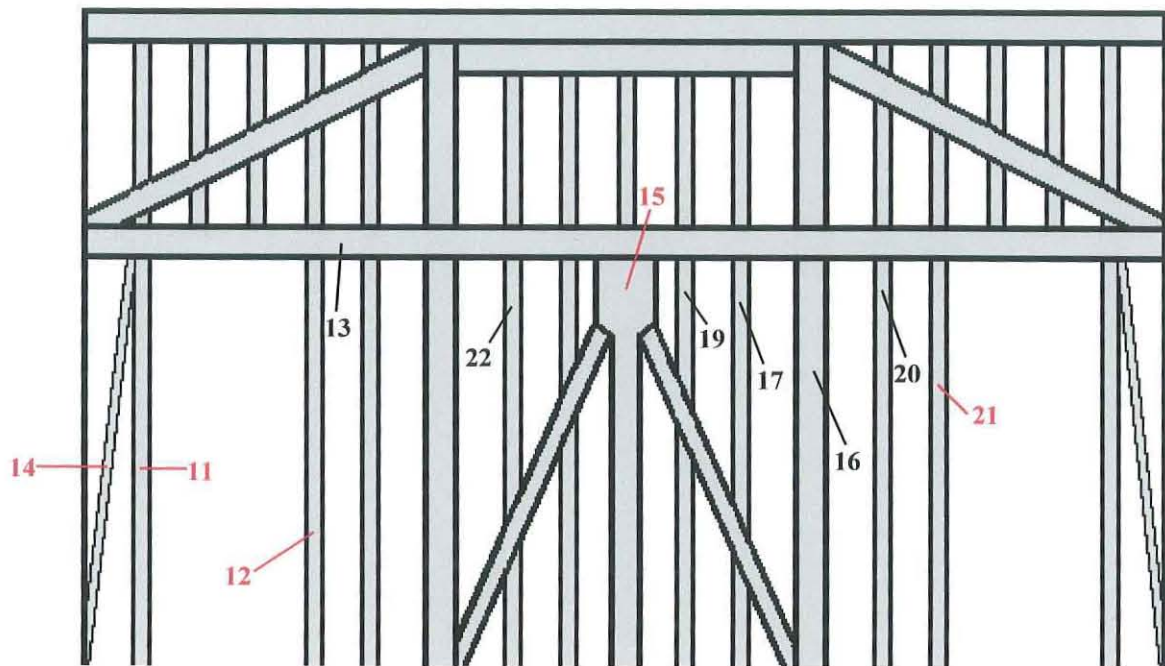

Figure 10: Photograph of south face of partition E, with partition F behind on the bedroom level (C Groves)



Figure 11: Schematic diagram the south face of partition E on the bedroom level showing the location of the sampled timbers. Dated timbers are indicated in **red**

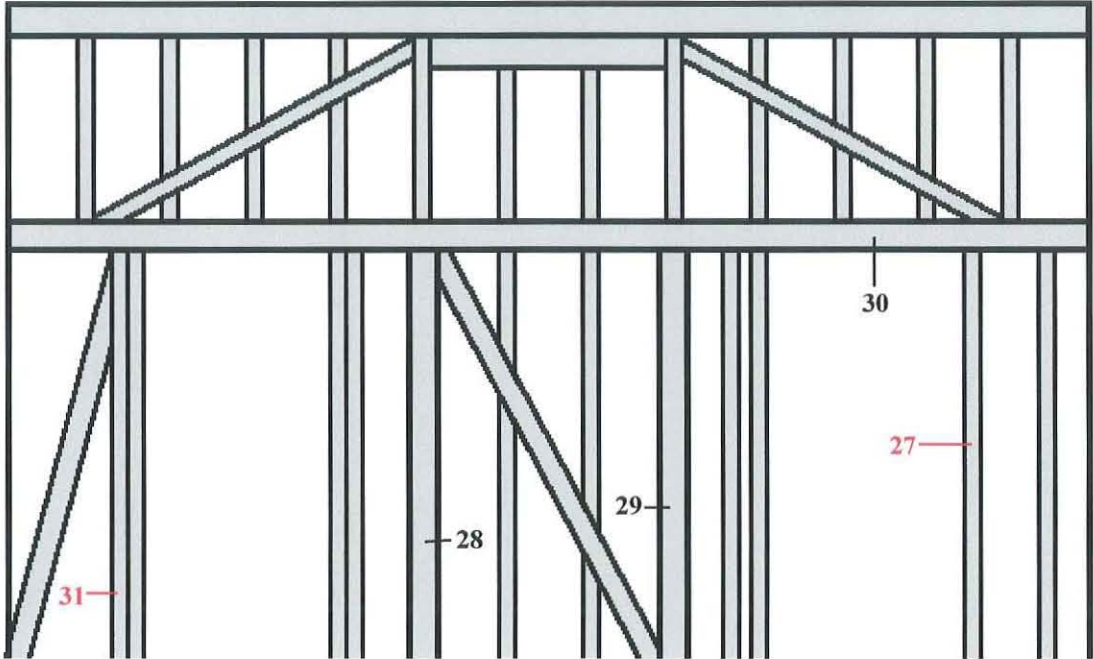

Figure 12: Schematic diagram of the north face of Partition F on the bedroom level showing the location of the sampled timbers. Dated timbers are indicated in **red**

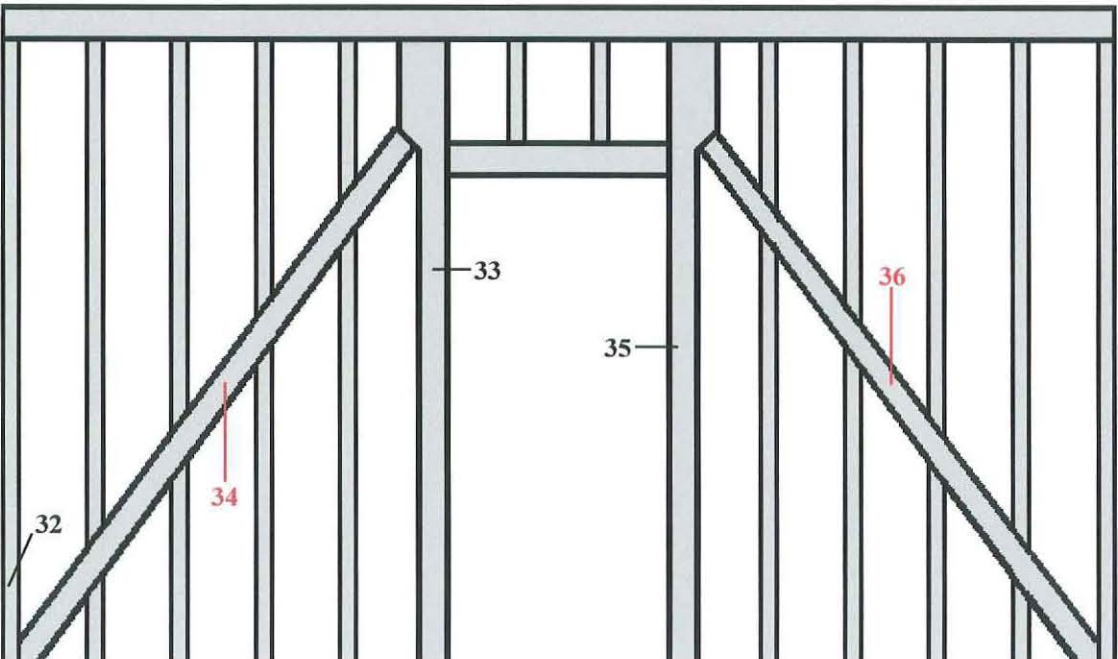

Figure 13: Bar diagram showing the relative positions of the matched ring sequences included in the site master chronology DANSON1. Possible same-tree groups are highlighted. Wide bar is measured ring sequence; narrow bar unmeasured rings

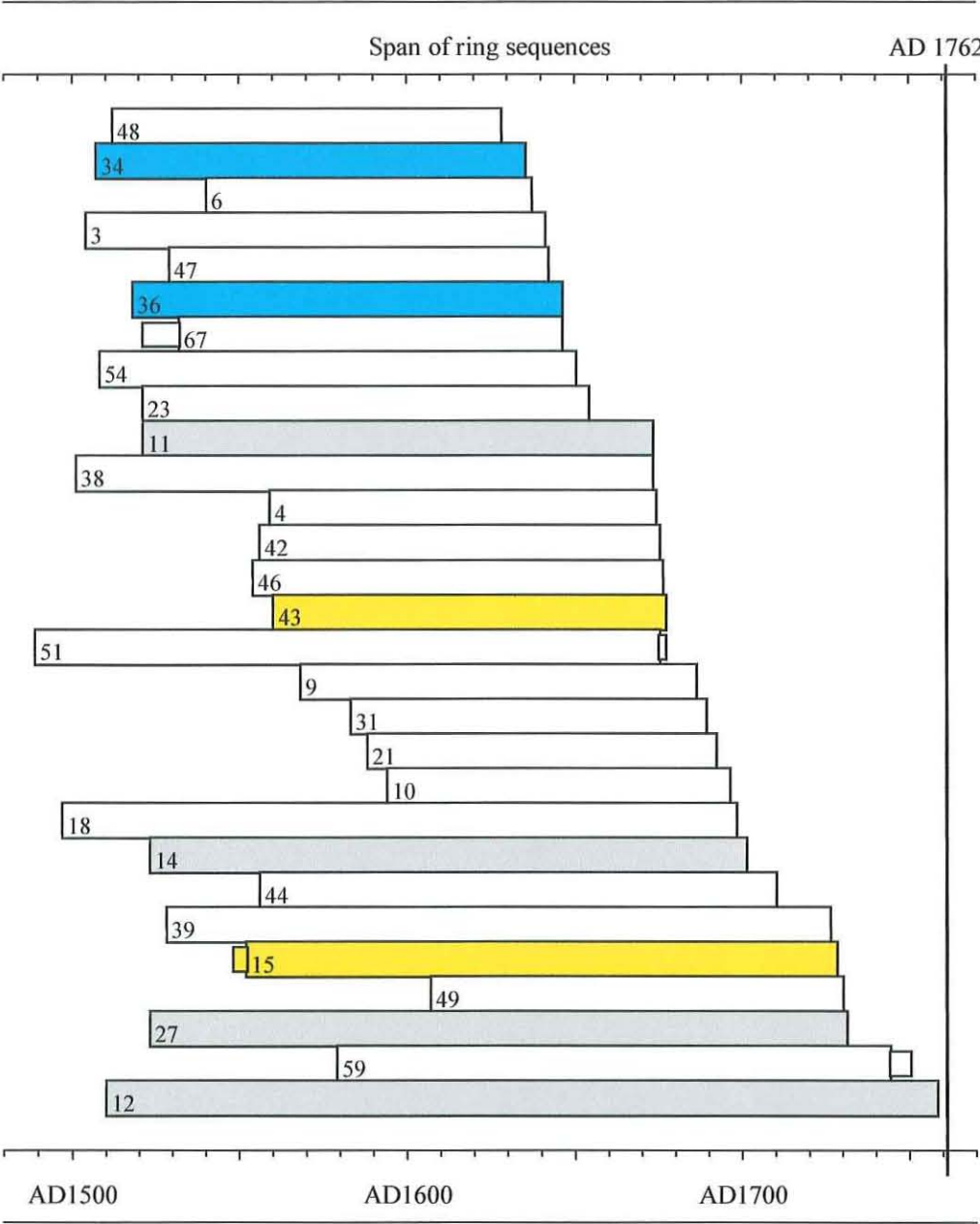

Figure 14: Bar diagram showing the relative positions of the matched ring sequences included in the site master chronology DANSON2. Possible same-tree groups are highlighted. Wide bar is measured ring sequence; narrow bar unmeasured rings

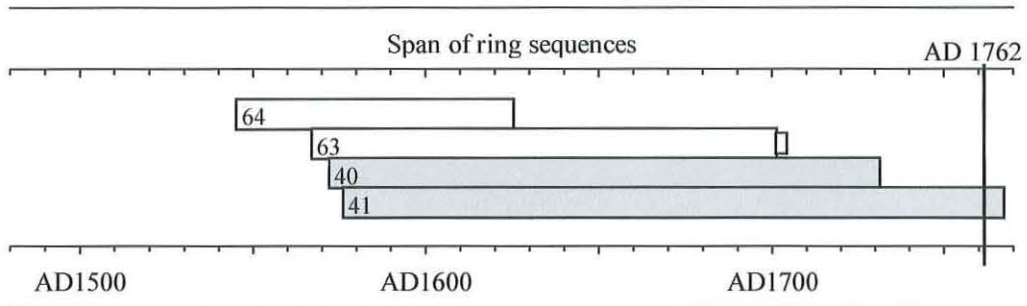

Figure 15: Bar diagram showing the relative positions of the matched ring sequences included in the site master chronologies DANSON3-DANSON7. Possible same-tree groups are highlighted. Note there is no matching between the groups. Wide bar is measured ring sequence; narrow bar unmeasured rings

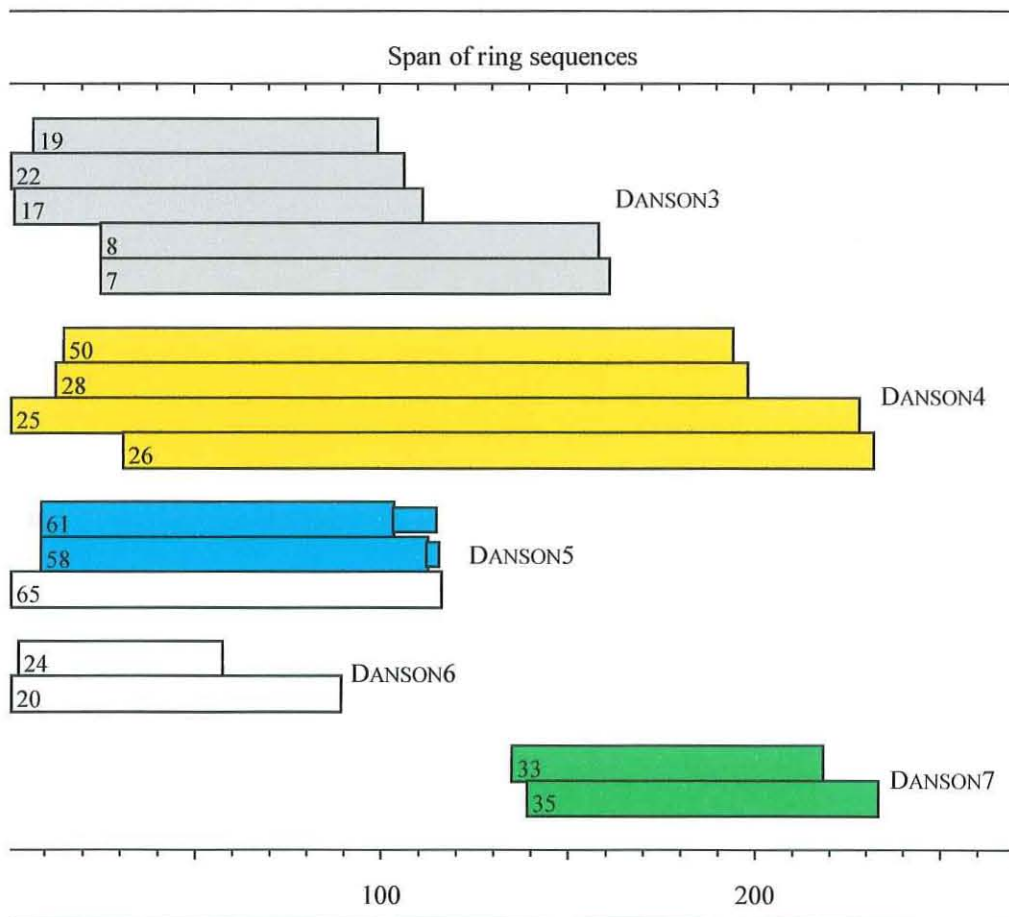

Figure 16: Plan of Danson Stables loft showing the location of the sampled timbers (after ELS Land Consultants 1994)

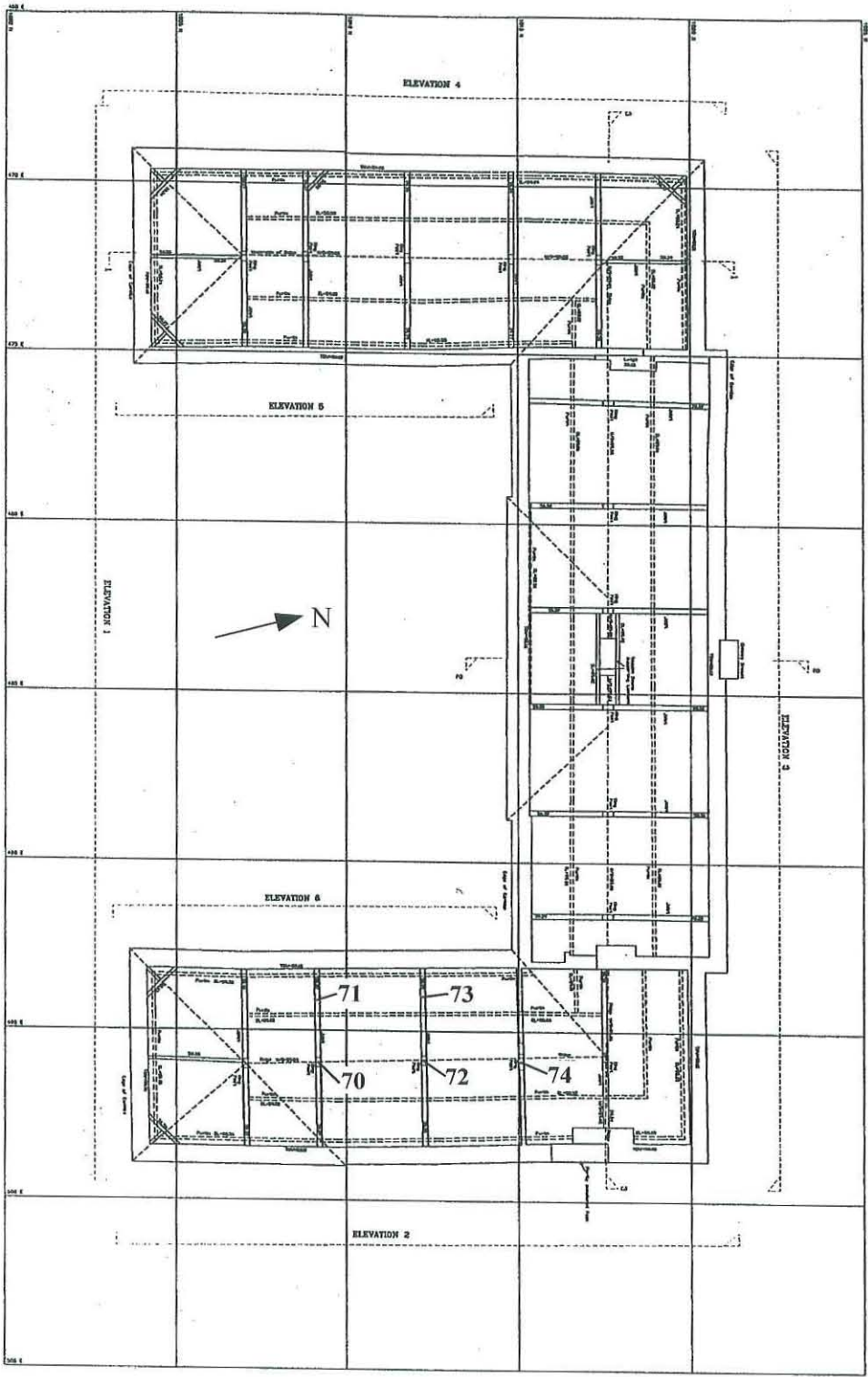

Figure 17: Diagram showing the ring sequences from four dated samples

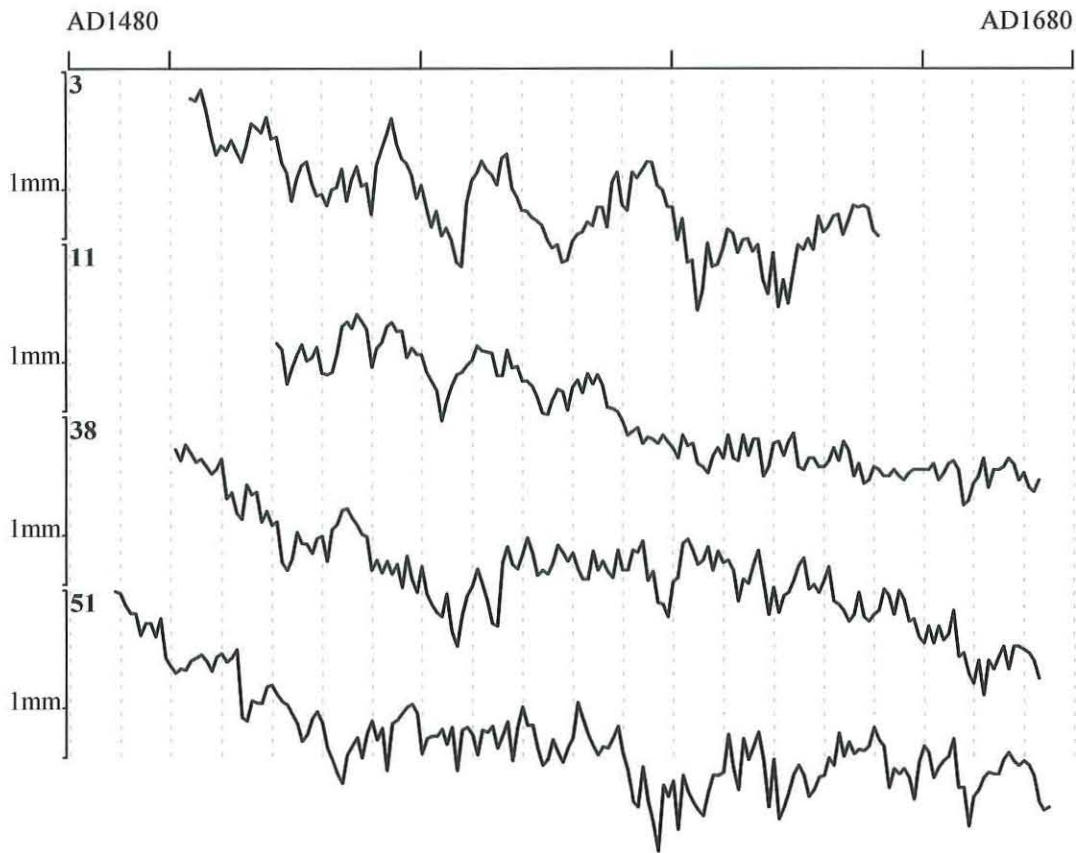

Figure 18: Diagram showing the ring sequences from four undated samples showing severe growth retardation events. Note there is no matching between the ring sequences shown

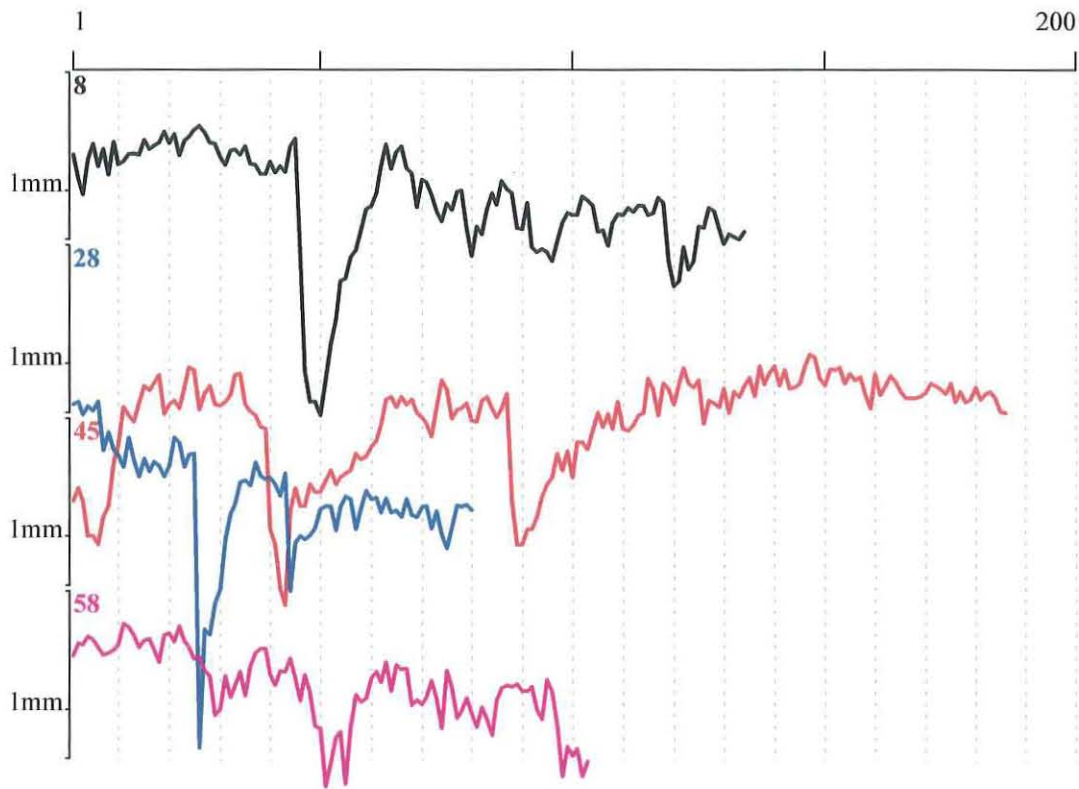
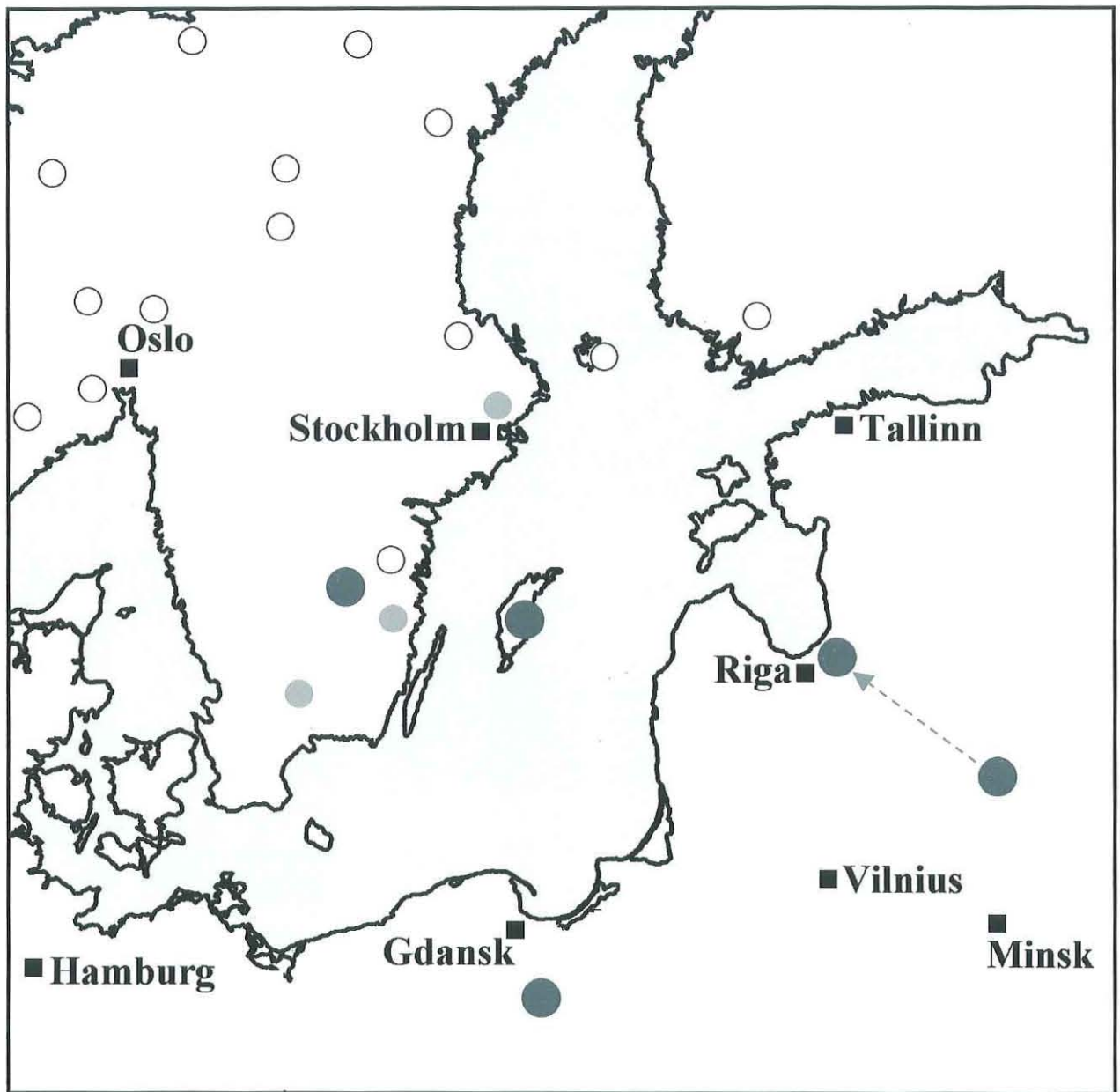

Figure 19: Geographical location of the reference chronologies with which DANSON2 matches indicating approximate source of the timbers used in the raising of the bays



Key

- *t* values >10.0
- 5.0-10.0
- 3.0 – 5.0
- <3.0

Figure 20: Geographical location of the reference chronologies with which DANSON1 matches indicating approximate source of the timbers used in the primary construction phase

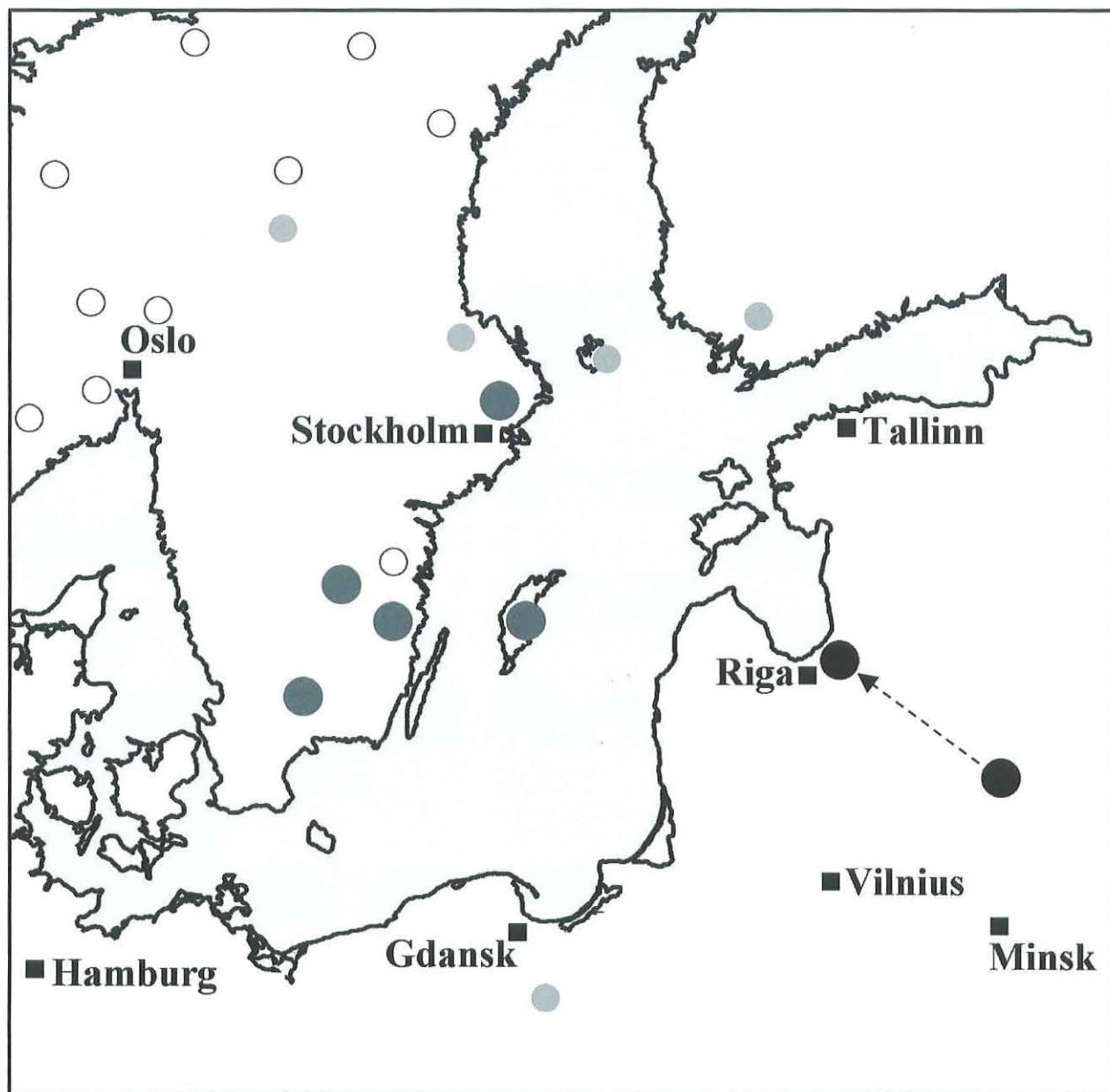

Key

- t values >10.0
- 5.0-10.0
- 3.0-5.0
- <3.0

Figure 21: Geographical location of the reference chronologies with which **55** matches indicating approximate source of the roofboard

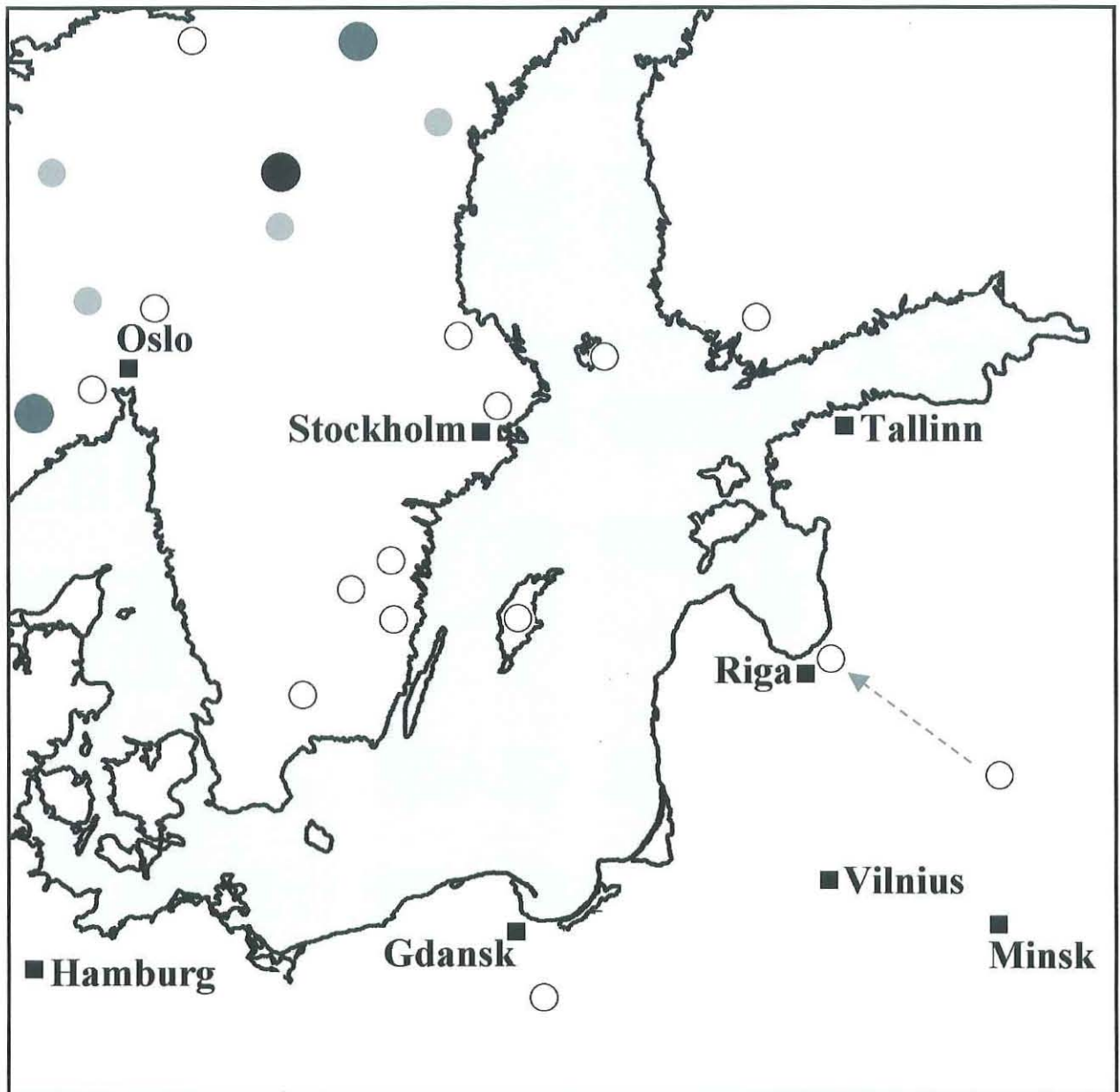

Key

- *t* values >10.0
- 5.0-10.0
- 3.0-5.0
- <3.0

Figure 22: Bar diagram showing the relative positions of all dated ring sequences sorted by end date. The components of and DANSON2 (blue) and 55 (red) are highlighted

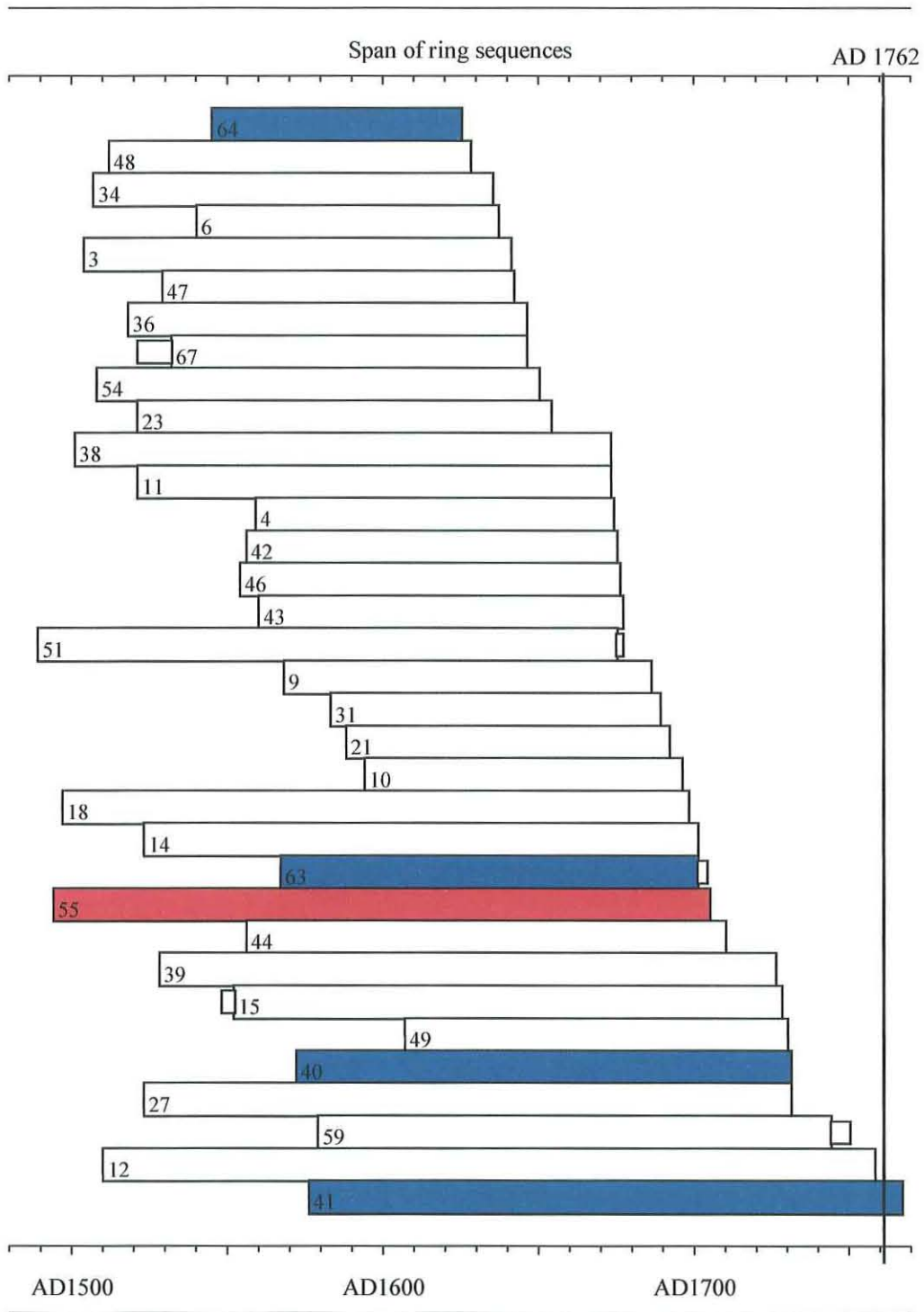

Figure 23: Bar diagram showing the relative positions of all dated ring sequences sorted by function or location. The components of and DANSON2 (blue) and 55 (red) are highlighted

