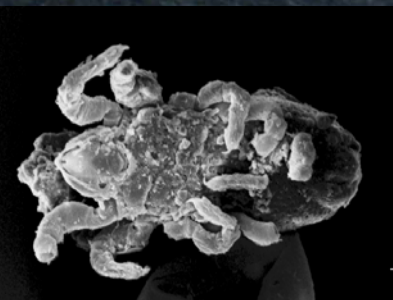


# TOWNFOOT FARM, CUMWHITTON, CUMBRIA INVESTIGATIVE CONSERVATION OF MATERIAL FROM THE VIKING CEMETERY

## ARCHAEOLOGICAL CONSERVATION REPORT

Jacqui Watson, Karla Graham, Angela Karsten, Lucy Skinner, Ulrike Schaefer, Sharon Penton,  
Jie Gao, Vanessa Fell, Jennifer Jones



*This report has been prepared for use on the internet and the images within it have been down-sampled to optimise downloading and printing speeds.*

*Please note that as a result of this down-sampling the images are not of the highest quality and some of the fine detail may be lost. Any person wishing to obtain a high resolution copy of this report should refer to the ordering information on the following page.*

**TOWNFOOT FARM  
CUMWHITTON  
CUMBRIA**

**INVESTIGATIVE CONSERVATION OF MATERIAL FROM THE  
VIKING CEMETERY**

Jacqui Watson, Karla Graham, Angela Karsten, Lucy Skinner, Ulrike Schaefer,  
Sharon Penton, Jie Gao, Vanessa Fell, Jennifer Jones

NGR: NY 5033 5250

© English Heritage

ISSN 1749-8775

*The Research Department Report Series incorporates reports from all the specialist teams within the English Heritage Research Department: Archaeological Science; Archaeological Archives; Historic Interiors Research and Conservation; Archaeological Projects; Aerial Survey and Investigation; Archaeological Survey and Investigation; Architectural Investigation; Imaging, Graphics and Survey, and the Survey of London. It replaces the former Centre for Archaeology Reports Series, the Archaeological Investigation Report Series and the Architectural Investigation Report Series.*

*Many of these are interim reports which make available the results of specialist investigations in advance of full publication. They are not usually subject to external refereeing, and their conclusions may sometimes have to be modified in the light of information not available at the time of the investigation. Where no final project report is available, readers are advised to consult the author before citing these reports in any publication. Opinions expressed in Research Department reports are those of the author(s) and are not necessarily those of English Heritage.*

*Requests for further hard copies, after the initial print run, can be made by emailing:*

*Res.reports@english-heritage.org.uk*

*or by writing to:*

*English Heritage, Fort Cumberland, Fort Cumberland Road, Eastney, Portsmouth PO4 9LD*

*Please note that a charge will be made to cover printing and postage.*

## SUMMARY

This report covers the investigative conservation of Viking material from Cumwhitton located to the south-west of Carlisle, Cumbria. In 2004 two early 10<sup>th</sup>-century tortoise shell-type brooches were found by metal detectorists in plough soil on farmland to the rear of Townfoot Farm. These were reported to the Portable Antiquities Scheme and subsequently an evaluation and English Heritage funded excavation were carried out by Oxford Archaeology North. This led to the discovery and excavation of a Viking period cemetery comprising 6 grave assemblages. The burials were in an extremely poor condition with little skeletal material remaining and the metalwork badly corroded and damaged. The assemblage comprised over 1000 small find numbers including 12 objects or groups of objects freeze-lifted, 7 large soil blocks and a number of smaller soil blocks. Numerous small finds and fragments were also excavated from the plough soil, many of which are disturbed from grave fills. Unusual finds include a sword, length of iron chain, drinking horn mounts and remains of a needlework box.

## KEYWORDS

Early Medieval  
Iron  
Copper alloy  
Glass  
Amber  
Jet  
Mineral preserved organic material  
Conservation  
Analysis

## CONTRIBUTORS

Jacqui Watson, Karla Graham, Angela Karsten, Lucy Skinner, Ulrike Schaeder, Sharon Penton, Jie Gao, Vanessa Fell, Jennifer Jones

## ACKNOWLEDGEMENTS

The authors would like to acknowledge the assistance provided by the following in the production of this report. Alan Lupton (OAN) for supplying the digital photos and grave plans reproduced here. Caroline Paterson (OAN) for the introducing Jacqui Watson to published examples of Viking boxes from Orkney and Scandinavia. Chris Evans (EH) for digitizing the excavation plans of the needlework box and producing the reconstruction. Harry Kenward (University of York) for identifying the insect remains on the tortoise brooches. Penelope Walton Rogers for identifying the seal hairs on a buckle.

## ARCHIVE LOCATION

Tullie House Museum and Art Gallery, Castle Street, Carlisle, Cumbria CA3 8TP

## DATE OF EXCAVATION

2004

## CONTACT DETAILS

Archaeological Conservation and Technology Team, Fort Cumberland, Fort Cumberland Road, Eastney, Portsmouth PO4 9LD

Karla Graham: [karla.graham@english-heritage.org.uk](mailto:karla.graham@english-heritage.org.uk)

Angela Karsten: [angela.karsten@english-heritage.org.uk](mailto:angela.karsten@english-heritage.org.uk)

## CONTENTS

Introduction .....	1
Condition of material.....	2
Ironwork .....	2
Copper alloy.....	2
Mineral preserved organic material.....	3
Glass, Amber and Jet.....	4
Conservation .....	4
Analysis.....	5
X-ray fluorescence (XRF) analysis.....	5
Fourier transform infra-red spectroscopy (FTIR) and X-ray diffraction (XRD) analysis .....	6
Investigative conservation.....	6
Grave 24 .....	6
Grave 24 Beads SF 776, 778, 799 to 802 and 804.....	7
Grave 24 Iron sword SF 779 .....	8
Grave 24 Copper alloy ring-pin with sword SF 779.....	11
Grave 24 Knife SF 780 .....	11
Grave 24 Fire-lighting kit SF 781, 786 to 789 .....	12
Grave 24 Iron buckles SF 782 and 783 .....	13
Grave 24 Iron rivet SF 9080 .....	14
Grave 25 .....	14
Grave 25 Iron sword SF 880 .....	16
Grave 25 Spearhead SF 881 .....	18
Grave 25 Beads SF 882 and 883 .....	18
Grave 25 Iron chain SF 884.....	18
Grave 25 Seax SF 885.....	19
Grave 25 Ring SF 887 .....	21
Grave 25 Drinking horn SF 889 .....	21
Grave 25 Copper alloy buckle and decorated plate SF 890 .....	22
Grave 25 Tin alloy decorative mount or finial SF 891 .....	23
Grave 25 Fire-lighting kit, copper alloy ring-pin and coin SF 892 .....	23
Grave 25 Iron spurs SF 893 and 897 .....	25
Grave 25 Copper alloy strap end SF 894 .....	25
Grave 27 .....	26
Grave 27 Drinking horn rim mount SF 784 .....	27
Grave 27 Shears, sickle and comb group SF 785 and finial SF 786 .....	27
Grave 27 Beads SF 790, 791, 807 to 810.....	29
Grave 27 Large copper alloy buckle SF 793.....	30
Grave 27 Copper alloy strap end SF 794 .....	32
Grave 27 Jet ring SF 805 and bracelet SF 792 .....	32
Grave 27 Neck ornament SF 806.....	33

Grave 32 .....	33
Grave 32 Buckle SF 864 .....	34
Grave 32 Spearhead SF 865 .....	35
Grave 32 Iron knife SF 866 .....	35
Grave 36 .....	37
Grave 36 Iron spearhead SF 899 .....	38
Grave 36 Ring-pin SF 900 .....	39
Grave 36 Sword SF 901 .....	39
Grave 36 Shield boss SF 903 .....	40
Grave 36 Iron object SF 905 and flint SF 906 .....	42
Grave 36 Bead SF 907 .....	42
Grave 36 Buckle SF 908 and Strap end SF 902 .....	42
Grave 36 Axe SF 1006 .....	43
Grave 85 .....	45
Grave 85 Tortoise Brooches SF1 .....	46
Grave 85 Knife handle SF 32 .....	51
Grave 85 Box and contents SF 33 .....	51
Viking metalwork from plough soil .....	62
Plough soil Sword hilt SF 29 .....	62
Plough soil Iron knife SF 31 .....	63
Plough soil Iron spearhead SF 31 I .....	63
Plough soil Fragments of sword blade SF 402 and SF 405 .....	63
Plough soil Iron knife SF 404 .....	63
Plough soil Iron fragments SF 409 .....	64
Plough soil Iron object SF 634 .....	64
Discussion .....	64
Swords .....	64
Spearheads .....	65
Axe .....	65
Shield .....	66
Knives .....	66
Shears .....	66
Needlework box .....	66
Combs .....	68
Drinking horns .....	68
Buckles .....	69
Summary .....	69
References .....	70
Appendix A: Analysis of Tortoise Brooches .....	72
Introduction .....	72
Methodology .....	72
Results and conclusions .....	74

## INTRODUCTION

Cumwhitton lies to the south-west of Carlisle, Cumbria and the underlying geology is the local red sandstone above red mudstones and silts. In 2004 two early 10<sup>th</sup>-century tortoise shell-type brooches were found in plough soil on farmland to the rear of Townfoot Farm. These were reported to the Portable Antiquities Scheme and subsequently an evaluation and English Heritage funded excavation were carried out by Oxford Archaeology North. This led to the discovery and excavation of a Viking period cemetery comprising 6 grave assemblages which are assumed, by the finds associated with them, to be of four male and two female burials (Brennand 2006 and Oxford Archaeology North 2008).

The burials were in an extremely poor condition, with little skeletal material remaining, and the metalwork badly corroded and damaged. The assemblage comprises over 1000 small find numbers including 12 objects or groups of objects freeze-lifted by Jennifer Jones (University of Durham), 7 large soil blocks and a number of smaller soil blocks contained within cardboard boxes. Numerous small finds and fragments were also excavated from the plough soil, many of which are disturbed from grave fills.

All the material was transferred to the English Heritage laboratories at Fort Cumberland and work proceeded in the following order:

- All the soil blocks were X-rayed.
- The material from the plough soil was X-rayed for Oxford Archaeology North (OAN) finds specialist Caroline Paterson.
- Excavation of soil blocks, in particular those that had been freeze-lifted and stored frozen as they remained very wet. To complete this work many of the objects required support and consolidation so that they could be X-rayed again. Where essential, samples of preserved organic materials were taken and identified.
- Further X-radiography to reveal the structure and any fine decoration of the individual items within the soil blocks; sometimes airbrading sections to clarify some objects.
- All the ironwork and most of the copper alloy (including objects from the soil blocks) have been re-packaged using Jiffy ® type foam, Plastazote ® or acid free tissue and kept in dry conditions (airtight containers with silica gel).

A large number of iron fragments were found in the plough soil. Preliminary examination was undertaken by Caroline Patterson to try to sort the modern from the archaeological finds prior to X-radiography. However, apart from the obviously modern objects, for instance tractor parts, it was not possible in each case to distinguish modern from old. When a selection of finds were X-rayed, objects believed to be medieval rivets were in fact modern screws and one indeterminate piece of ironwork actually turned out to be a spearhead socket highly decorated with white metal inlay. It was therefore decided that all the metalwork would be X-rayed except for those finds where it was possible to identify them as modern from visual appearance alone.



This report provides an overview of the condition of the archaeological material, details of the conservation and analytical work undertaken and a discussion of the results. Individual object details are organized by grave and from the plough soil (Viking material). Appendix A includes the detailed analytical results for the tortoise brooches.

## CONDITION OF MATERIAL

The soils at Cumwhitton are very acidic and aggressive to most materials, so that no bones or evidence for the bodies remain, and the metalwork placed in the graves is extremely corroded. Any evidence for organic objects, such as clothing or the organic components attached to metalwork, only remain in the iron corrosion, or in close proximity to copper salts.

### Ironwork

X-radiography revealed that all the ironwork is heavily corroded, and in many cases the objects are hollow with the surface blistered and distorted. In some extreme cases such as the tinned spurs, the tin has been preserved as a metal layer at the expense of the iron core which in places has completely dissolved away. Despite their poor condition X-radiography has revealed a great deal of information about manufacture and their original appearance. The knife SF 885 and all the swords (probably four) are pattern welded with different designs, but the corrosion of the blades may have caused some distortion of the pattern. Certainly none of these objects are of much value for in-depth metallurgical study due to the degree of corrosion they have undergone (Fig. 1).



*Figure 1: The broken section of a sword blade, revealing a hollow and distorted centre.*

### Copper alloy

The copper alloy objects are extremely fragile and fragmentary. X-radiography showed that many of these items were broken within the soil blocks that were used to remove

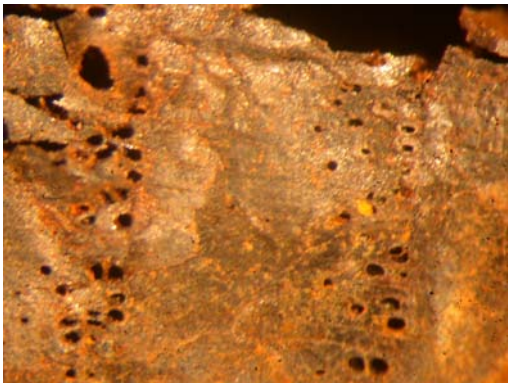
them from site (Fig. 2). The unusual conditions at Cumwhitton have resulted in metallic bronze objects (copper/tin alloys) being reduced to a green stained tin oxide in the form of a compressed powder, that has taken up the original shape and size of the metal piece but with no mechanical strength (Scott 2002, 39).

All of the excavated copper alloys were analysed, using X-ray Fluorescence (XRF), as part of the conservation process to identify any surface coatings. Unfortunately, the highly mineralized and de-cuprified state of these objects means that any figures quoted are just a rough indication of the original metal composition.

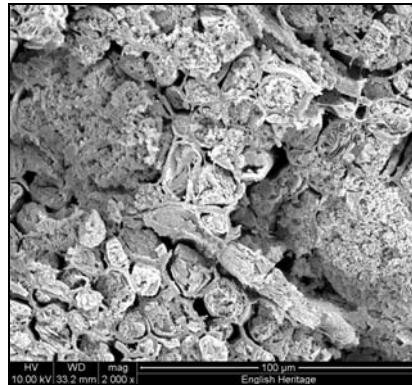


*Figure 2: Detail of a copper alloy buckle plate beginning to fracture during removal from its soil support.*

### Mineral preserved organic material



*Figure 3: Cross section of mineral preserved wood in socket of spearhead SF 89.*



*Figure 4: Micrograph of the cross section of mineral preserved wood from sword scabbard SF 402. Unidentified due to condition (SEM B888b).*

There is wide variation in the preservation of organic material, with horn and wood well preserved on the ironwork, but leather only remains as a compact or powdery surface. Leather is more recognizable on the copper alloy metalwork such as buckles. Textile is preserved in many cases by iron corrosion, either on iron objects such as the swords or on copper alloy brooches by the iron pins.

Where possible most of the mineral preserved organic material has been identified using either incident light microscopy (Fig. 3) or by examining gold coated samples in the scanning electron microscope (SEM), and when the latter technique has been used the sample number is quoted in the catalogue. The condition of much of the mineral preserved wood meant that it has not always been possible to confirm the species when viewed at high magnification (Fig. 4).

As no organic material has been preserved on the site, the mineral preserved remains provide the sole evidence for many objects that were included in the graves along with the organic components the metalwork was attached to.

### **Glass, Amber and Jet**

Most of the glass and amber beads are in a good condition and do not require further work. A glass linen smoother (SF 33) or click stone was located in the grave 85 soil block containing the textile equipment, this appears to be a rare survival of a wood ash glass object. This object was allowed to dry slowly, but in the process lost its blue colour, and even after consolidation with Paraloid B72 the surface remains grey and opaque.

The two jet-like objects, a ring (SF 805) and bangle (SF 792) are in a good condition and have been identified (by X-Ray Fluorescence analysis, X-radiography and Fourier transform infra-red spectroscopy) as being made from oil shale or canal coal rather than the expected Whitby jet that they are visibly indistinguishable from (Penton 2008). A recent study of the Viking jet objects from Scotland collections has also come to the same conclusion that these objects were in fact made from lignite or canal coal which can be found in many locations in the north of England, Scotland and Ireland (Hunter 2008).

## **CONSERVATION**

All the soil blocks were carefully dismantled to retrieve all the finds that were visible on the X-radiographs, but in some cases the fragments required temporary consolidation while the supporting soil was removed.

Cyclododecane (CDD), a cyclic hydrocarbon, was used to support these fragmentary areas by applying a 60% w/v solution in white spirit. After the solvent had evaporated the wax-like CDD provided enough support for the removal of the soil (Fig. 5), and

application of more permanent supports using Japanese tissue attached with Paraloid B72 (acrylic co-polymer). The CDD was then allowed to sublime from the surface of the objects at room temperature or by applying gentle heat from a desk lamp or hairdryer. Once all the CDD had been removed, additional consolidation with Paraloid B72 in Industrial Methylated Spirits (IMS) could be applied locally.



*Figure 5: Cyclododecane (CDD) used to hold fractured pieces of a buckle in place during conservation.*

Paraloid B72 and HMG Cellulose Nitrate have also been used for all the repairs on both the copper alloy and ironwork.

The condition of some objects is so poor that it has been impossible to locate everything visible on the X-radiographs, such as the small silver wires on a large knife (seax) handle from grave 25 (SF 885), see Figs. 30 and 31.

## ANALYSIS

### X-ray fluorescence (XRF) analysis

X-ray fluorescence (XRF) analysis, a non-destructive technique, was used to determine the chemical nature of inorganic artefacts and samples including for example the copper alloy and some of the shale (Grave 27 SF 792 and 805). However, corrosion and other surface effects will alter the composition at the surface and the results need careful interpretation. In the case of many of the copper alloy objects from Cumwhitton extreme de-cuprification means that the XRF results could be misinterpreted as the objects being made from high tin alloys rather than bronzes!

## Fourier transform infra-red spectroscopy (FTIR) and X-ray diffraction (XRD) analysis

Fourier transform infra-red-spectroscopy (FTIR) analysis is mainly used for the analysis of organic materials, through the production of spectra which are then compared to known examples. It was also used in association with X-ray Diffraction (XRD) analysis to identify non-crystalline corrosion products (Grave 85 SF I Tortoise brooches).

## INVESTIGATIVE CONSERVATION

The following chapters provide information on the investigative conservation carried out on grave goods. Each chapter includes a grave plan, tabulated grave contents followed by pertinent findings from the investigative conservation. The discussion section which follows (p.67) considers the finds by object type.

## GRAVE 24

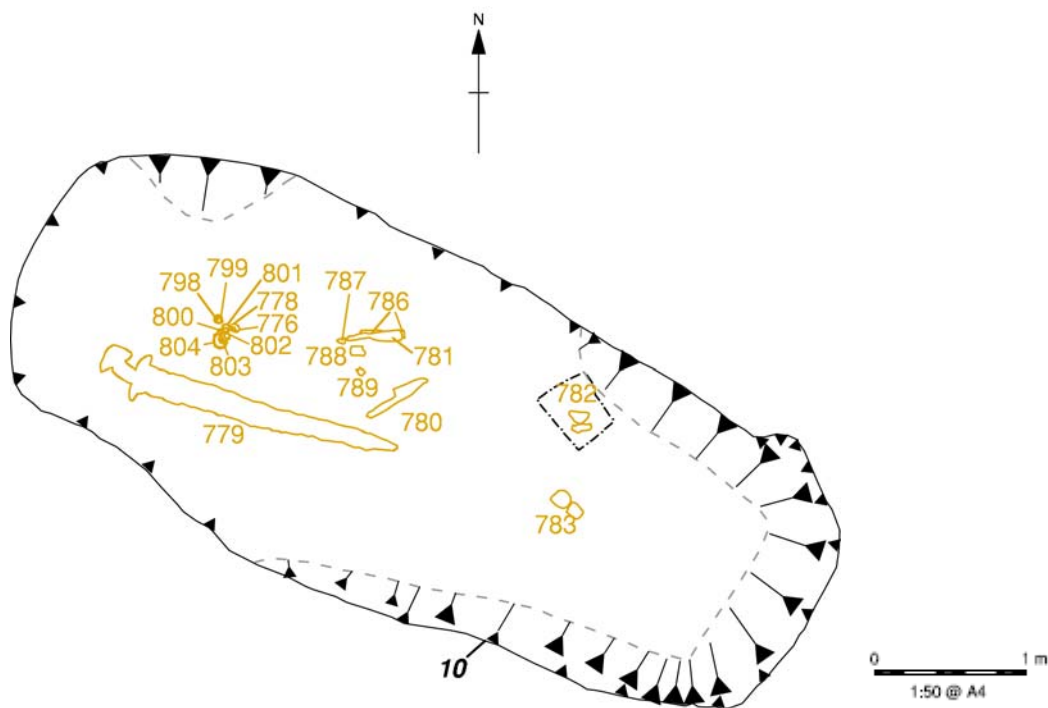


Figure 6: Grave 24 plan © OAN

Table 1: Grave 24 conservation summary and X-radiograph numbers.

SF No.	X-ray No	Material	Object	Notes
776		Glass	Melon bead.	Green
778		Glass	Bead	Green/blue
779	P1652- P1657, P1665- P1668	Iron Copper alloy	Sword fragment Ring-pin	Sword with preserved horn on hilt and inlaid decoration on pommel and guard.
780	P1767	Iron	Knife	Small blade and well preserved wood/horn handle.
781	P1739, P1741, P1759	Iron	Purse mount/pivot knife	
782		iron	Buckle	Tinned
783	P1984	Iron	Buckle	Tinned surface.
786			Whetstone	Whetstone, in association with folding knife SF781? Worn from use. White material on surface has impression of pupae cases preserved in it. This may be from folding knife sheath or decomposing body
787		Flint	Flint	Associated with fire-lighting kit – striker?
788		Flint	Flint	Associated with fire lighting kit – striker?
789		Flint	Flint	Associated with fire lighting kit – striker?
798		Silver	Ring	Not seen – treasure trove.
799		Glass	Beads	1 green and 1 blue
800		Glass (?)	Red bead	
801		Amber	Large bead	
802		Glass	Blue bead.	
803		Silver	Ring	Not seen – treasure trove.
804		Glass	Bead	
9080	P1731	Iron	Rivet.	

### Grave 24 Beads SF 776, 778, 799 to 802 and 804

The six glass beads of different colours and shapes (SF 776, 778, 799, 800, 802, 804) and one amber bead (SF 801) were found clustered together with the two silver rings (SF 798 and 803). Both the glass and amber are in a good condition (Fig. 7).



*Figure 7 Glass and Amber beads.*

### **Grave 24 Iron sword SF 779**

This sword was excavated and lifted in two sections: the main sword (blade, hilt) and the sword tip. A thick layer of soil had been left attached to the sword and following a programme of X-radiography, the soil was mechanically removed (Fig. 8).



*Figure 8: Sword SF 779.*

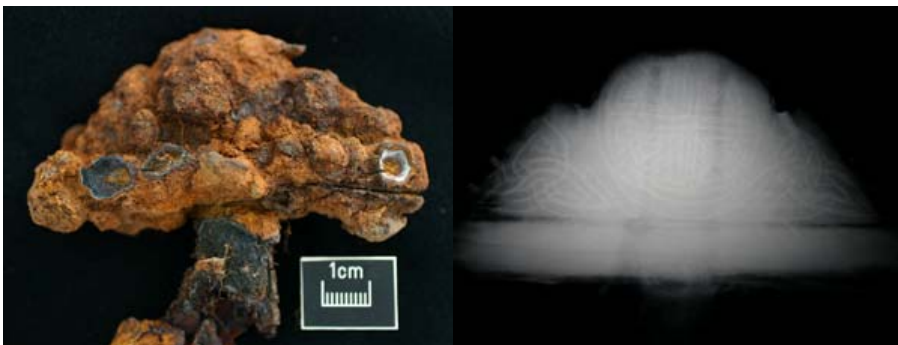
The pommel (length 4.1 cm, width 8.5cm, thickness 18.2mm) is covered in corrosion blisters and extremely heavy compared to the remaining sword. On the X-radiographs it first appeared as a solid white area but on the edge of the pommel distinct dense white lines were present indicating a possible inlay (Fig. 9). The pommel was X-rayed at higher



intensities and this revealed an intricate pattern on both sides of the pommel, and stereo-radiography was attempted to try to separate out the decoration on the two sides but it was not possible to produce a stereo image due to the very uneven nature of the object.



*Figure 9: X-Radiograph of SF 779: pommel, hilt and guard.*



*Figure 10: SF 779 pommel and its accompanying x-radiograph.*

Although an inlay was visible in the x-ray images, the detail could not be clarified by the removal of soil and light corrosion. Any attempt to reveal the inlay would involve the use of destructive techniques. The x-radiographs also show the construction details of the pommel: the location of the socket into which the hilt is fitted.

The grip was bent almost half way along its length before or at some stage during its burial. It measures 70 mm in length, and tapers from 26 mm at the lower guard to 17 mm at the upper guard. On one side an area of mineral preserved horn is located towards the lower guard (Fig 11). At low magnification, the horn can be seen to run under the lower guard. Traces of mineral preserved horn are also present on the opposing side of the hilt again near the lower guard.





*Figure 11: SF 779: pommel and grip showing the area of well preserved horn.*

The lower guard is highly corroded with many corrosion blisters, and X-radiography revealed inlaid decoration just evident as dense white lines on the edges of the guard (Fig. 12). No remains of the inlay were revealed after the removal of soil and light corrosion.



*Figure 12: SF 779: detail of inlay decoration around the edge of the guard.*

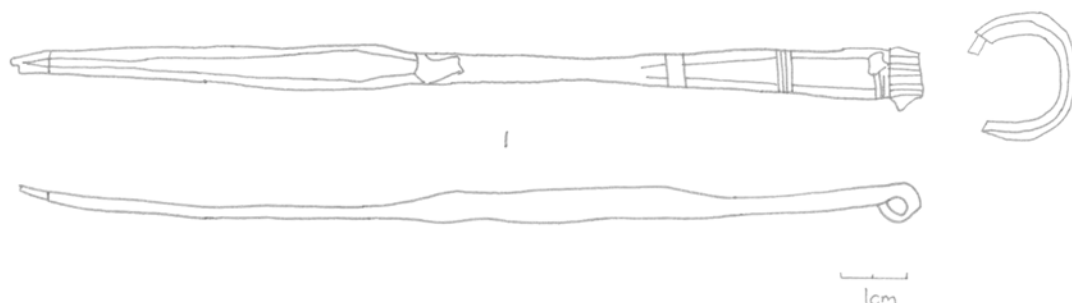
The blade measures 72.3cm in length, between 3.7 and 5.5cm in width and the thickness is 1.5mm at the blade edge and 4.2mm in the centre of the blade. The X-radiographs reveal that the blade is highly corroded with very little of the core remaining and numerous corrosion blisters present. Several X-radiographs were taken at different intensities to ascertain technological details such as pattern welding but no evidence was found although, as the blade is highly corroded such details may have been lost.

On the sword tip there are two patches of mineral preserved leather evident as compact, light coloured deposits.

### Grave 24 Copper alloy ring-pin with sword SF 779

The copper alloy ring-pin was found underneath the sword in the soil block. The copper alloy object comprises a long pin (length 14.1 cm; width 2.4 - 7.7 mm; thickness 1.2 - 5.5 mm) and a small ring (diameter 19.7 mm; thickness 3.5 mm) from which the pin would have hung (Fig. 13). The upper and lower ends of the pin are rectangular in section and the central area is round in section. There is an incised line (0.1 mm wide) running near the edge on the flat sections. The pin tapers towards the tip which has broken off. Overall, the surface of the copper alloy appears to be in a good condition and the incised decoration is well preserved but where the tip has broken off it exposes a friable body. Light soil was removed using a scalpel under binocular magnification.

The ring was recovered in several pieces with the part of the ring broken off remaining inside the looped top of the pin. The ring is diamond in section apart from where it is attached to the pin; this is round in section. The surface of each diamond face (2.5 mm width) has an incised line (0.1 mm width) running along the centre. Overall, the diamond section appears in a fair condition with the original surface intact and little or no corrosion whereas the round sections are extremely friable with powdery light green corrosion products.



*Figure 13: Copper alloy ring pin located beneath sword SF 779.*

### Grave 24 Knife SF 780

Iron knife with small blade and well preserved handle, probably of wood but not identified (Fig. 14). On the blade are traces of what could be the remains of a leather sheath.



*Figure 14: Iron knife SF 780 and its X-ray image.*

### **Grave 24 Fire-lighting kit SF 781, 786 to 789**

This group was found together and is probably a set of tools used for fire lighting. It includes an iron purse mount or pivot knife SF 781 (Fig. 15), a whetstone SF 786 (Fig. 16) and three flint flakes SF 787 – 789 (Fig. 17). The presence of pupae cases amongst the corrosion products suggest that they were placed in a container such as a leather bag. The iron purse mount or knife is much corroded, but the X-ray images suggest that it might be a folding knife with the blade folded back into the handle (Fig. 15 lower images).



*Figure 15: Iron mount/pivot knife SF 781 and X-ray images (plan and section).*



Figure 16: Whetstone SF 786.



SF 787



SF 788



SF 789

Figure 17: Group of three flints associated with the fire lighting kit.

### Grave 24 Iron buckles SF 782 and 783

These two iron buckles are tin-plated, and so corroded that they are hollow in places with just the tin remaining (Fig. 18). They are almost identical to the buckles in grave 25 associated with the spurs (SF 893 and 897), and may be all that remains of a pair of spurs in this grave.



Figure 18: Tinned iron buckle SF 783 and X-ray image (enlarged).

## Grave 24 Iron rivet SF 9080

An iron rivet with sections of mineral preserved antler is probably all that remains of a composite antler comb (Fig. 19).

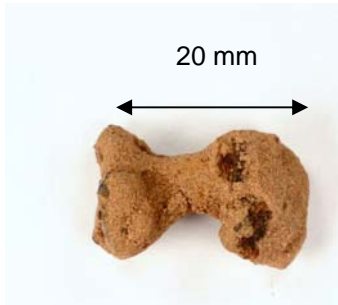


Figure 19: Iron rivet SF 9080.

## GRAVE 25

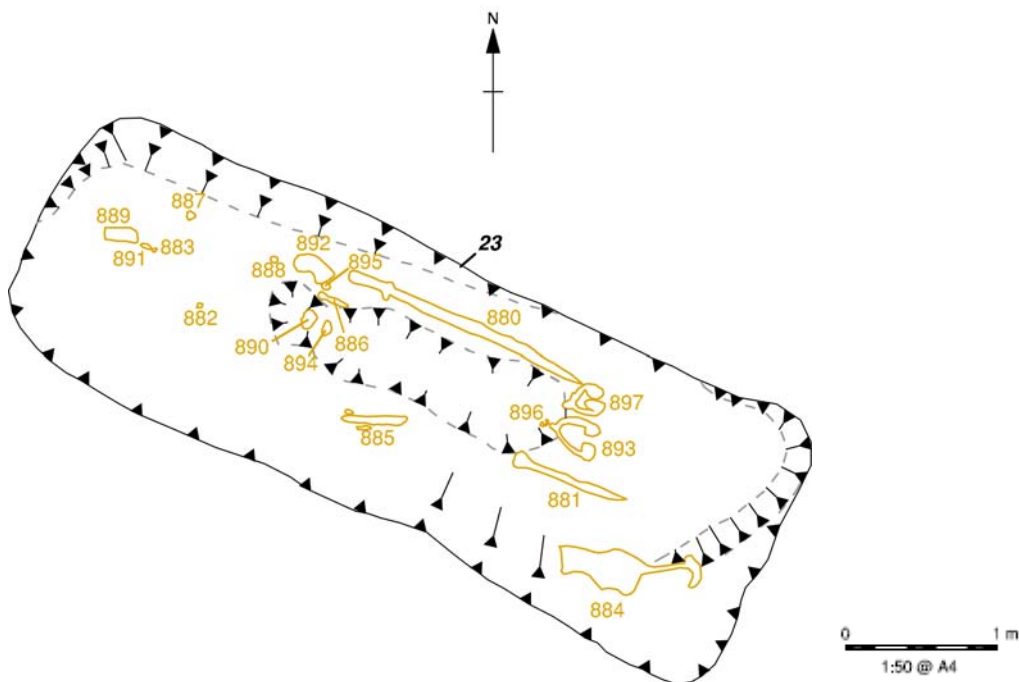


Figure 20: Grave 25 plan © OAN.

Table 2: Grave 25 conservation summary and X-radiograph numbers.

SF No.	X-ray No	Material	Object	Notes
880	PI753, PI754, PI755	Iron	Sword	Sword in three fragments with intricate pattern welding. Small strap end found in soil block. Some scabbard survives in the corrosion layers but is highly distorted and discontinuous. Fe is highly mineralised and blade hollow, blistered and concreted with hardened soil. The soil block has been excavated and the individual pieces removed, unfortunately the strap end has broken and the fragments have had to be consolidated.  Wood stiffener: willow ( <i>Salix</i> sp.) or poplar ( <i>Populus</i> sp.): SEM B893
881	D5183, D5184, PI704	Iron	Spearhead	
882	PI889	Glass	Bead	Red, black and white flower like decoration.
883		Amber	Bead.	
884	PI742, PI743, PI746, PI748, PI916, PI922, PI924, PI946	Iron	Chain	Pile of iron chain with a point at one end and large hook at other end; and is heavily corroded. Excavated from the soil block, and one section cleaned to expose the shape of the links. Condition is highly mineralised/ hollow and blistered.
885	PI737	Iron	Seax	Horn handle inlaid with silver wire motifs. SEM B895
886	PI730, PI732, PI761	Iron	Strap end or pivot knife	
887	PI889	Copper alloy	Ring pin, with broken pin	X-radiograph shows uneven but heavy corrosion. Some mineral preserved hairs attached.
888	PI889, PI890	Lead	Sub-circular object	Highly mineralized.
889	PI735, PI740	Copper alloy	Drinking horn mount	The X-ray images show how the mount was attached to the horn rim, with two layers of thin copper alloy sheet attached to both the inner and outer surfaces of the horn and held in place by riveted clips. Further X-radiography revealed that the thin metal is decorated with delicate interlace work. Highly fragmented and vulnerable to further damage.
890	PI719, PI723	Copper alloy	Belt buckle	In an extremely friable and fragmented state.
891	PI889, PI890	Tin	Mount	Rectangular cavity in centre, and possibly decorated on the outside.

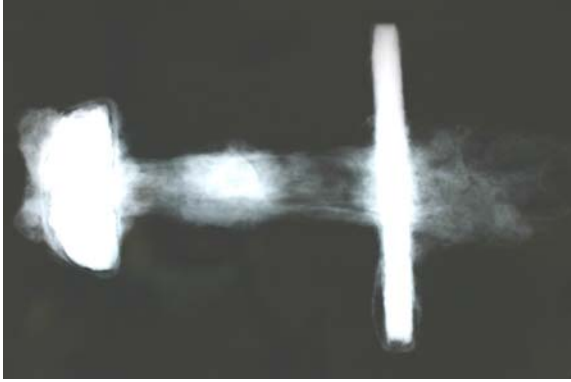
SF No.	X-ray No	Material	Object	Notes
892	PI727, PI760	Iron, copper alloy and flint	Fire-lighting kit	Mixture of materials including: 2 flints, two copper alloy ring pins, an iron knife with scabbard, and a coin. The copper alloy ring pins are highly corroded, one had organic remains around. The scabbard of the knife is fragile, the wood is crumbling. The coin is in good condition.  XRF: silver is present in the coin, lead present on the surfaces of every piece.  XRD: gave no result of lead
893	PI753, PI754, PI755, PI964	Iron	Spur	Well preserved tinned surface. Parallel line decoration on upper surface and mineral preserved leather and textile from possible boot with textile lining. Buckle and strap guide are also tinned and preserve leather from strap.
894	PI731	Copper alloy	Strap end	Matches strap end found with sword (SF 880). Black layer on both sides - may be skin/leather. One side has a layer of mineral preserved wood on top of the black layer- its purpose is not known.
895	PI926	Copper alloy	Object	Some copper alloy fragments together with soil (white colour) and brown iron corrosion product.
896	PI889	Copper alloy	Buckle loop	Extremely corroded with some mineral preserved skin/leather on certain areas.
897	PI753, PI754, PI755, PI964	Iron	Spur	Has a decorated tinned surface that is well preserved.

### Grave 25 Iron sword SF 880

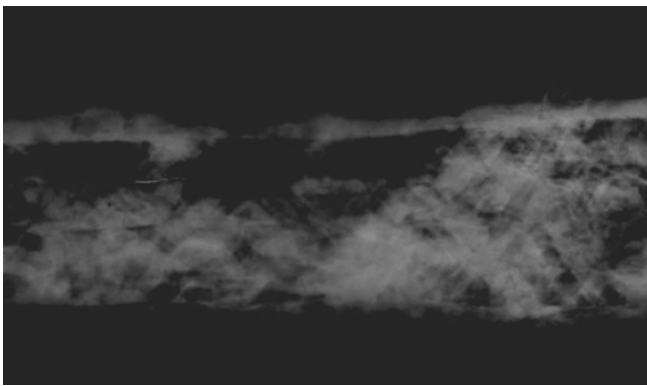
The sword was removed from the soil block in three fragments, and the X-ray images indicate hilt type (Fig. 21) and that the blade was originally pattern welded (Fig. 22). The grip was presumably made from an organic material, but it was not possible to identify what material was used from the traces that remain on the tang.

Along the length of the blade are layers of miscellaneous organic materials that originally formed part of the composite scabbard. Unfortunately these have been distorted by large corrosion blisters (Fig. 23) so that the construction of the original scabbard has had to be pieced together from different areas of the blade. The evidence indicates that it had wooden stiffeners made from willow (*Salix* sp.) or poplar (*Populus* sp.) with textile next to the blade, and with possible leather on top of the wood holding the whole construction together. Plant stems were also recorded, but these are more likely to have been placed in the grave to cover the floor or the burial before complete interment.

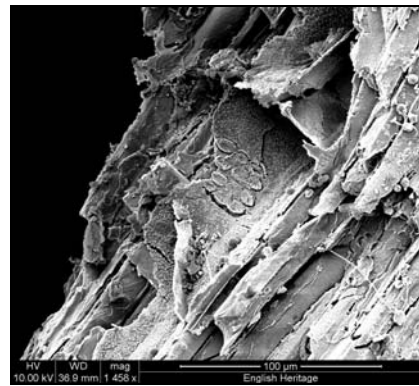




*Figure 21: X-radiograph of sword SF 880 hilt.*



*Figure 22: SF 880 X-radiograph of pattern welded section.*



*Figure 23: SF 880 Electron micrograph of wood from the scabbard, illustrating the large vessel/ray pitting. SEM B893*

A small copper alloy strap end, decorated on one side, was found underneath the sword in the soil block (Fig. 24). It is very like SF 894 mount, and maybe a scabbard mount.



*Figure 24: Copper alloy mount found beneath sword SF 880.*



## Grave 25 Spearhead SF 881

Large spearhead in several pieces found at foot of grave near the spurs (SF 893 and 897). There were no wood remains in the socket.

## Grave 25 Beads SF 882 and 883

SF 882 is a black and white glass bead (Fig 25a and b). Amber bead SF 883 was found near the tin alloy mount SF 891 so could potentially have been suspended or attached to the drinking horn (SF 889).



a



b



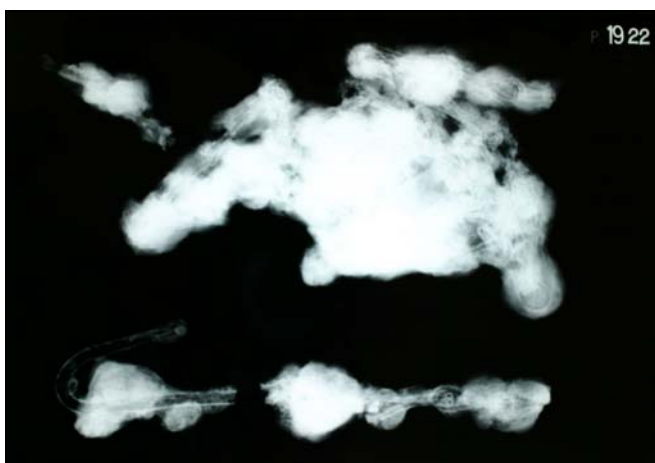
c

*Figure 25a and b: SF 882 Glass bead c. 12.5mm in diameter.*

*c: SF 883 Amber bead c. 11mm in diameter.*

## Grave 25 Iron chain SF 884

SF 884 is a pile of iron chain with a point at one end and large hook at the other end (Figs. 26 – 28). It is heavily corroded to the point of most of the links being hollow. As a result it has not been possible to clarify all the links.



*Figure 26: X-radiograph of chain SF 884.*



*Figure 27: SF 884 Large mass of chain with the loose soil removed.*



*Figure 28: SF 884 Hooked end of chain, after conservation.*

### **Grave 25 Seax SF 885**

Iron seax with a horn handle and remains of a leather scabbard on the blade, was lifted in a soil block and carefully excavated in the laboratory (Fig. 29). Although the iron blade remains in one piece, with large corrosion blisters, the organic additions are very friable.

Fine non-ferrous (probably silver) wires formed into two different shapes have been inlaid into the horn handle. These are organised as lines of the same motif running the length of the tang. It was not possible to clarify this detail on the object and the X-radiograph remains the only image of the overall design (Figs. 30 and 31).

The leather scabbard was originally reinforced at the edges with copper alloy bar sewn onto both sides (Fig. 29), although these may have been a single piece chape originally (one piece measures at least 150 x 5 x 2mm).



*Figure 29: Seax SF 885 during excavation from soil block.*



*Figure 30: X-radiograph of seax SF 885.*



*Figure 31: SF 885 Detail of the silver wires inlaid into the horn handle.*

## Grave 25 Ring SF 887

A suspension ring very similar to the one attached to the drinking horn rim mount (SF 889), and its position in the grave suggests that it could be a second suspension ring fixed to the tip of the horn.

## Grave 25 Drinking horn SF 889

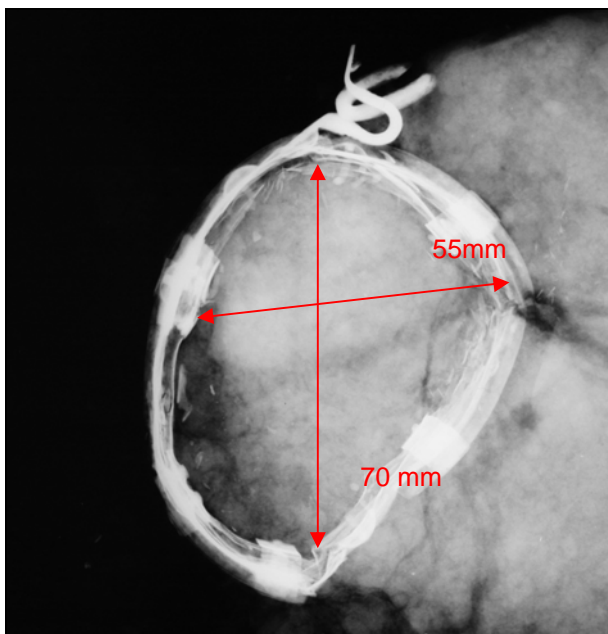


Figure 32: SF 889 X-radiograph of rim mount in the soil block.

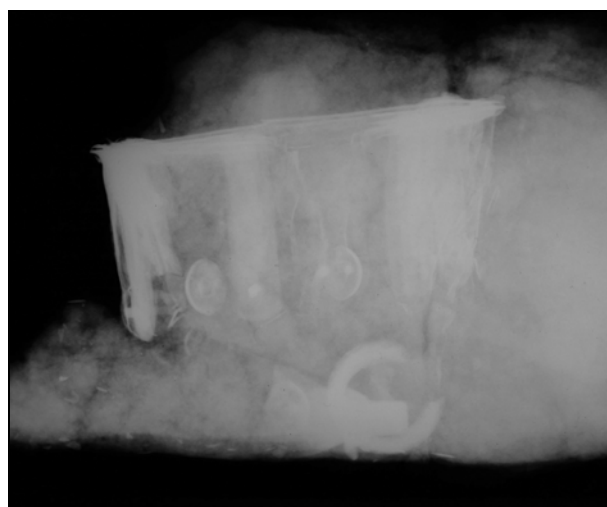


Figure 33: SF 889 Side view of soil block containing rim mount.



Figure 34: SF 889 Decorated section of the rim mount.

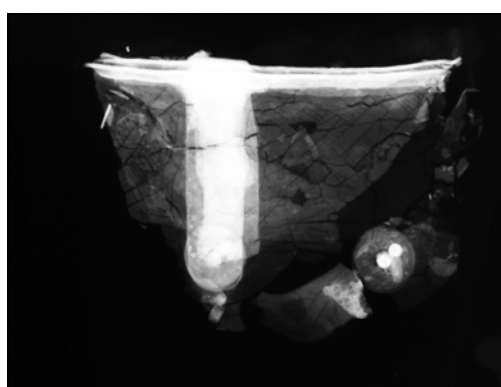


Figure 35: SF 889 X-radiograph illustrates the layers of copper alloy forming the rim mount.

Copper alloy drinking horn mount lifted in a soil block. The X-ray images (Figs. 32, 33 and 35) show how the mount was attached to the horn rim, with two layers of thin copper alloy sheet attached to both the inner and outer surfaces of the horn and held in place by riveted clips (Fig. 36). Further X-radiography revealed that the thin metal is decorated with delicate interlace work.

The mount was squashed, potentially during burial, so that the section of the horn is now elliptical and 55 - 70mm across (see Fig. 32). The metal has completely mineralized and came apart when the block was excavated. The ring is now in fragments which no longer join as the edges have disintegrated. Attempts have been made to clarify the decoration (Fig. 34), but more detail may be visible in the X-ray images.

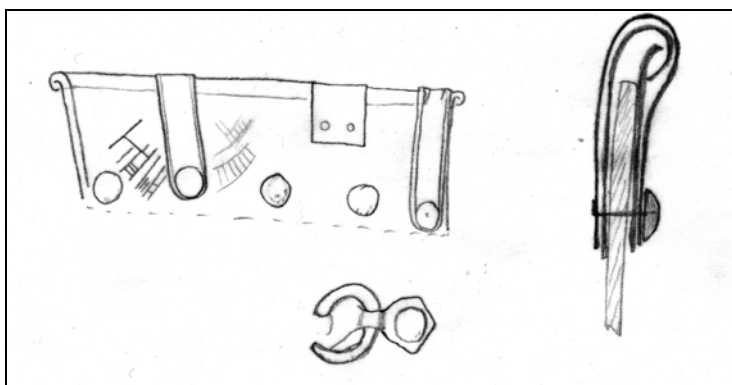


Figure 36: Construction of the SF 889 copper alloy rim mount (drawing L. Skinner).

### Grave 25 Copper alloy buckle and decorated plate SF 890



Figure 37: SF 890 Copper alloy buckle and buckle plate.



Figure 38: X-radiograph of SF 890.

Copper alloy buckle and plate in many fragments and in a friable condition (Fig. 37). The X-radiograph shows that it was highly decorated, with ring and dot motifs on the buckle plate. The buckle plate made from thin metal sheets held together and attached to the leather belt with five copper alloy rivets (Fig. 38), very similar to the buckle from grave 32 (SF 864). Remains of the leather belt were preserved between the thin metal plates.



## Grave 25 Tin alloy decorative mount or finial SF 891

This small decorative mount has a rectangular cavity in the centre where it would have been mounted onto an organic object that has not been preserved (Fig. 39). It was found near the drinking horn rim mount (SF 889) and may therefore be related to that object, such as the displaced terminal. XRF analysis of the metal found it to be mainly tin with some lead and copper, which means that it is most likely to be a type of pewter, but with significant amounts of lead and copper dissolved out of the original alloy. Alternatively this could be the remains of soft solder used to fill the back of a metal boss where the decorated thin metal has been lost.



*Figure 39: SF 891 Top: recessed area, indicated by red arrow. Bottom: side view of finial where the roughly finished surface may have been covered with thin metal foil that has been lost.*

## Grave 25 Fire-lighting kit, copper alloy ring-pin and coin SF 892

Heavily corroded group comprising an iron mount/pivot knife, copper alloy ring pin, flints and a coin (Fig. 40). Their close proximity to each other suggests that they might have been in some sort of container such as a leather bag.

The coin was removed from the flint and corrosion removed to reveal the letters and decoration (Figs 41 and 42). XRF indicated that it contained silver, and was probably base silver originally. The copper alloy ring pin is in a very poor condition and appears to be another example of a de-cuprified bronze alloy (Fig. 43).



Figure 40: SF 892 Corroded group.

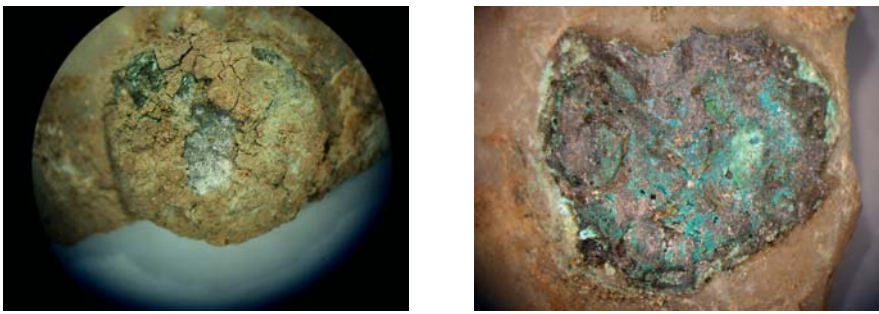


Figure 41: SF 892 Base silver coin corroded onto flint, before and after cleaning to reveal detail

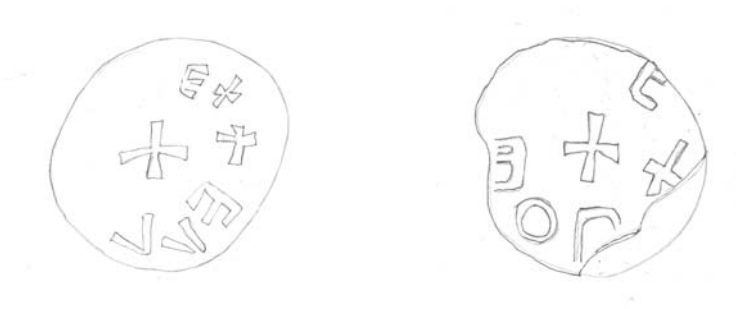


Figure 42: SF 892 Detail on both sides of the coin.



Figure 43: SF 892 Copper alloy ring-pin.

## Grave 25 Iron spurs SF 893 and 897

Iron spurs SF 893 and 897 have well preserved tinned surfaces with the outer surfaces decorated with parallel lines (Fig. 44). Organic materials are preserved on the inner side, which appear to be areas of leather and textile that may be the remains of a leather boot with textile lining (Fig. 45). The buckle and strap guides are also tinned and have remains of the leather strap preserved on them. The spurs were excavated from the soil block and the corrosion removed to reveal the decorated tinned surface on the buckles.



Figure 44: Pair of iron spurs and x-ray image of SF 893 and 897.

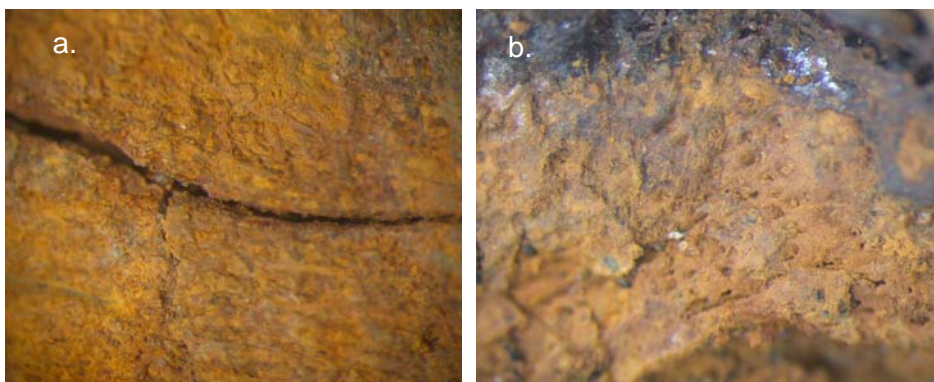


Figure 45: Mineral preserved textile (a) and leather (b) from inner side of spur SF 893.

## Grave 25 Copper alloy strap end SF 894

Copper alloy strap end which matches the strap end found with sword SF 880. A black layer on both sides may be skin or leather. One side has a layer of mineral preserved wood on top of the black layer - its purpose is not known (Fig. 46).



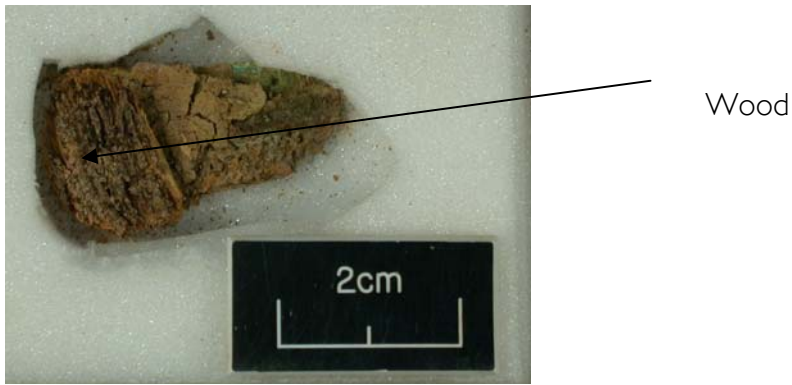


Figure 46: SF 894 Copper alloy mount with wood and possible skin or leather preserved on it

## GRAVE 27

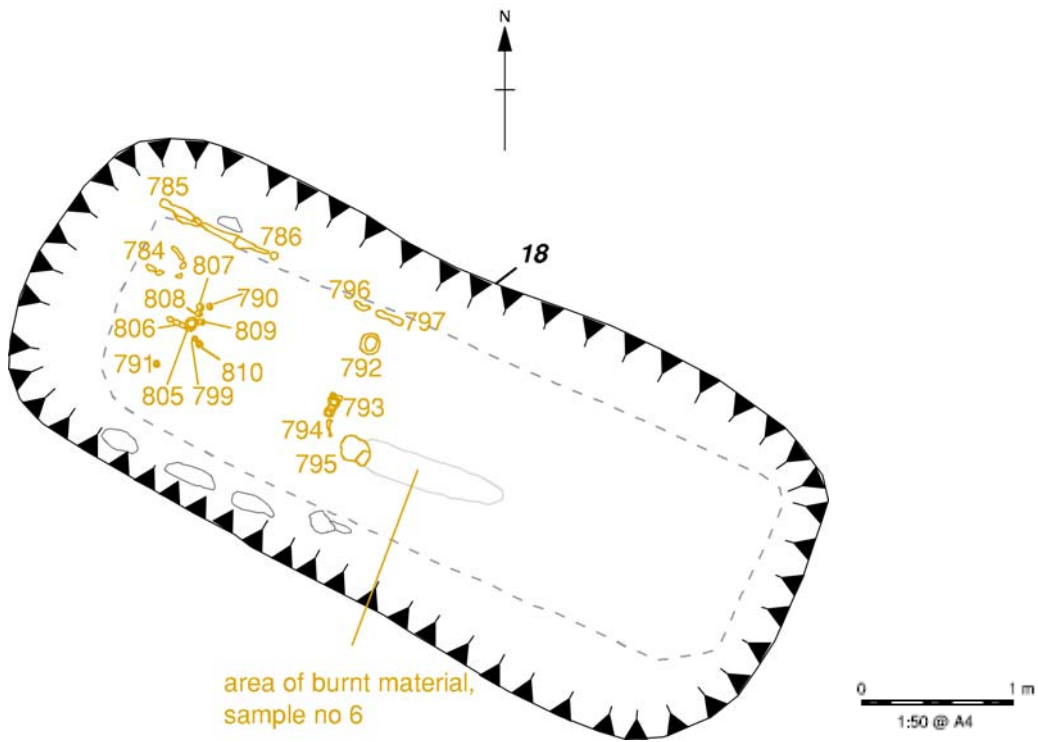


Figure 47: Grave 27 plan © OAN.

Table 3: Grave 27 conservation summary and X-radiograph numbers.

SF No.	X-ray No	Material	Object	Notes
777		Copper alloy	Fragments	
784	PI725, PI762	Copper alloy	Drinking horn mount	
785	PI749, PI750, PI960	Iron, bone/antler and copper alloy	Shears, sickle, comb and ball shaped object	Iron shears and sickle corroded together with bone /antler comb. Also a copper alloy ball shaped object (possible cosmetic brush).
790		Glass	Bead	Green
791		Glass	Bead	Green
792	PI943	Jet	Bracelet	
793	PI721	Copper alloy	Belt fitting	Decorated
794	PI722, PI769	Copper alloy	Belt fitting	Highly mineralised and friable - vulnerable to damage. Appears to have fibres from cord attached.
795	PI983	Textile	Chape	X-ray suggests it may be the decorated chape of scabbard.
796	PI731, PI768	Iron	Bent object	
797	PI731, PI768	Iron	Flat disk shaped object in fragments	
805	PI943	Jet	Ring	
806	PI769	Copper alloy	Neck ornament	
807		Glass	Bead	Green
808		Glass	Bead	Green
809		Glass	Bead	Green
810		Glass	Bead	Green

### Grave 27 Drinking horn rim mount SF 784

Thin curved copper alloy sheet with mineral preserved horn on the inside. As this item was found at the head end of the grave, and was originally mounted on horn, these fragments of copper alloy are probably all that remain of a drinking horn.

### Grave 27 Shears, sickle and comb group SF 785 and finial SF 786

This group was found at the side of the grave, and the objects (sickle, shears and comb) placed on top of each other as though they had been placed together in some form of container such as a leather bag (Figs. 48 and 49). The X-radiograph (Fig. 50) illustrates how badly corroded the ironwork is with some areas left as hollow sections. Little remains of the composite antler comb except for the iron rivets along with areas of the side-plates and tooth plate that were in direct contact with the iron shears. Although little remains of this antler comb, it has been possible to produce a reconstruction of it (Fig.

52), including the ring and dot motifs found in a few places. A close parallel for this comb is illustrated in McGregor (1985, 86).

Also associated with this group is a small copper alloy ball shaped finial (SF 786), but it was no longer attached to anything, so its function is unknown, although it is possibly the handle to a small item such as a cosmetic brush.



Figure 48: SF 785 Shears, sickle and comb group after excavation from the soil block.

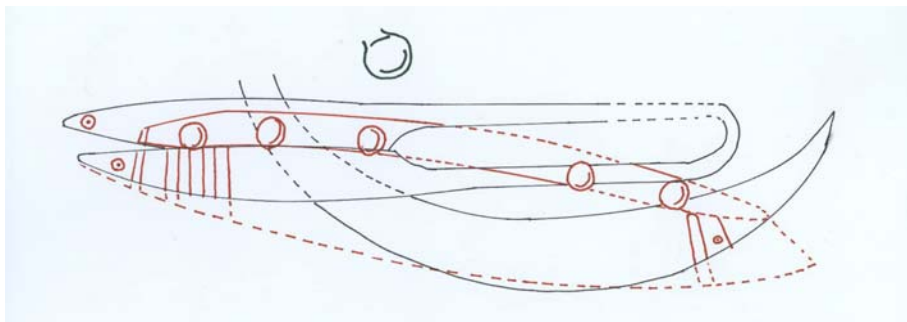


Figure 49: SF 785 Plan of group with an approximate outline of the antler comb and position of the copper alloy fitting.

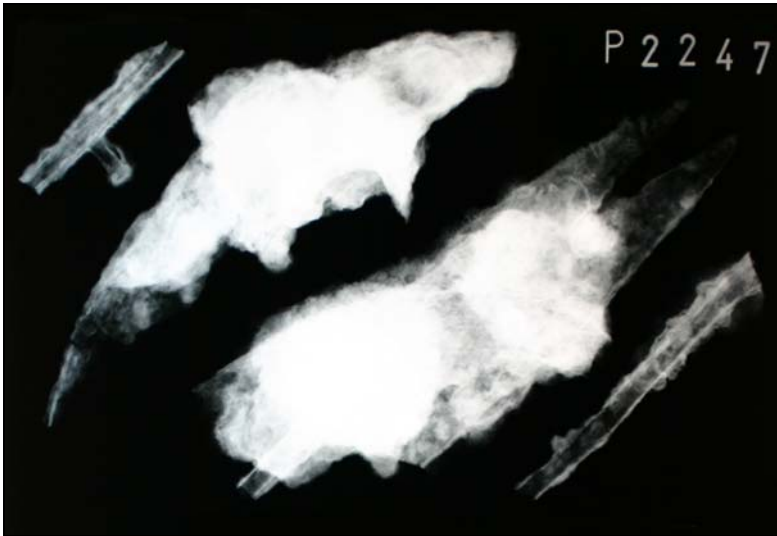


Figure 50: SF 785 X-radiograph of the shears group.

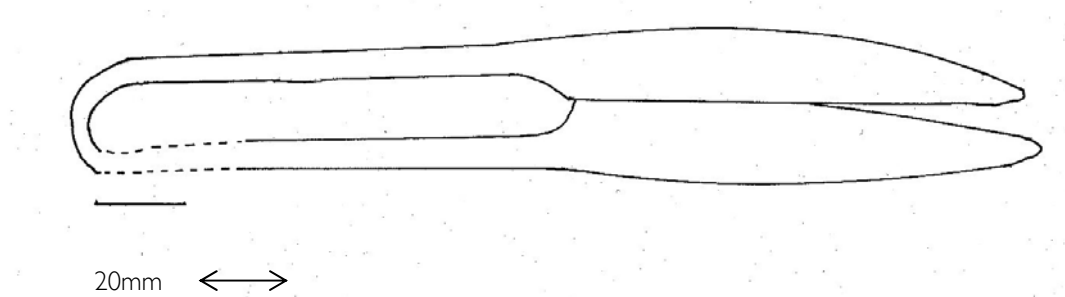


Figure 51: SF. 785 Iron shears drawn from the x-radiograph.

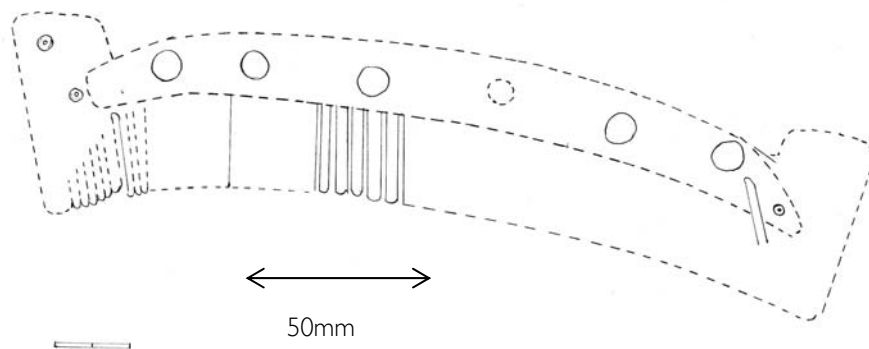
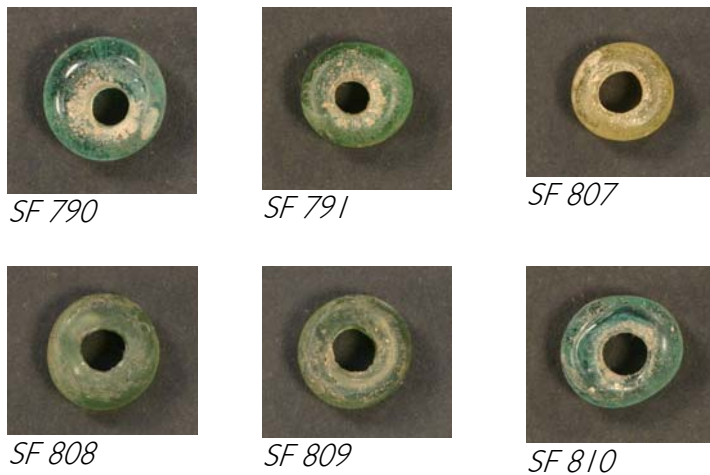


Figure 52: SF 785 Reconstruction of the composite antler comb preserved on the shears and sickle, with some decoration remaining.

### Grave 27 Beads SF 790, 791, 807 to 810

Six pale green glass beads, all of which appear to be stable and in good condition (Fig. 53).



*Figure 53: Glass beads, approximately actual size.*

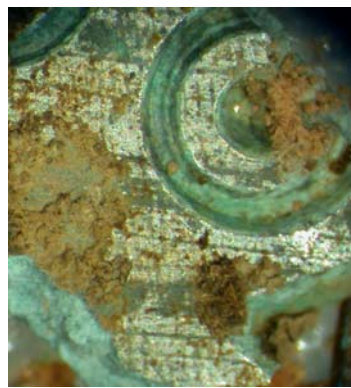
### **Grave 27 Large copper alloy buckle SF 793**

A large decorated copper alloy buckle with associated mineral preserved organic materials, and found in the centre of the grave presumably at the waist.

Analysis revealed that they were probably made from leaded bronze originally, but are now highly decuprified to the extent that some areas are mainly tin oxides. As little metal remains the object is very brittle and friable. Both the buckle plate and loop are decorated and the design can be seen clearly in the X-radiograph (Fig. 54). The surface of the buckle plate was originally coated in tin which survives as a white metal in places (Fig. 55).



*Figure 54: SF 793 X-radiograph of copper alloy buckle.*



*Figure 55: SF 793 Tinned surface.*

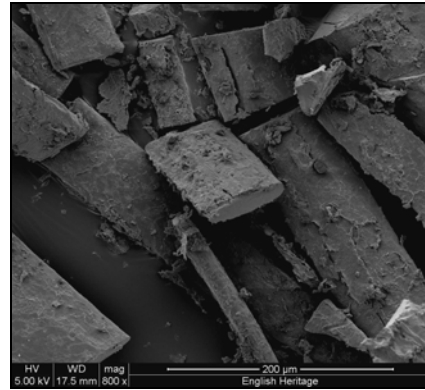
The buckle was originally mounted on an animal skin or pelt, with very coarse but straight and shiny black hairs (Figs. 56 and 57). These hairs are quite unlike the more common sheep, goat or cow hairs as they are very flat in cross section (Fig. 58), and appear to sit on top of each other which would have given the pelt a smooth and shiny appearance. Penelope Walton Rogers has identified the hairs as most likely to have come from a seal, and that the buckle may be fastening for a sealskin cape or long waistcoat (pers comm).



*Figure 56: SF 793 Fracture in buckle plate revealing the black fibres.*



*Figure 57: SF 793 Enlarged view of hairs under the buckle plate.*



*Figure 58: SF 793 Electron micrograph of the black hairs B900.*

During conservation the thin back-plate of the buckle became detached and revealed a large area of textile that had been preserved between the two copper alloy plates. Fortuitously the buckle plate also covered a seam illustrated in Figure 59. This textile seems to be a tabby weave, made from a vegetable fibre such as linen, and might be the remains of a lining to the sealskin cape or waistcoat.





*Figure 59: SF 793 Textile found under the buckle-plate, on the reverse side.*

#### **Grave 27 Copper alloy strap end SF 794**

The decoration on the copper alloy strap end SF 794 is optimally viewed in the X-radiograph (Fig. 60).



Figure 60: X-radiograph of strap end SF 794.

#### **Grave 27 Jet ring SF 805 and bracelet SF 792**

These two jet-like objects were found to be made from oil shale or canal coal when analysed (rather than Whitby jet which they closely resemble in colour and condition). The ring (SF 805) was found surrounded by glass beads (SF790, 791, 807 to 810) and may be part of the necklace rather than a finger ring.

## Grave 27 Neck ornament SF 806

Miscellaneous fragments of copper alloy that might have been part of a necklace clasp or pendant, but are in a poor condition and it is not possible to repair them.

## GRAVE 32

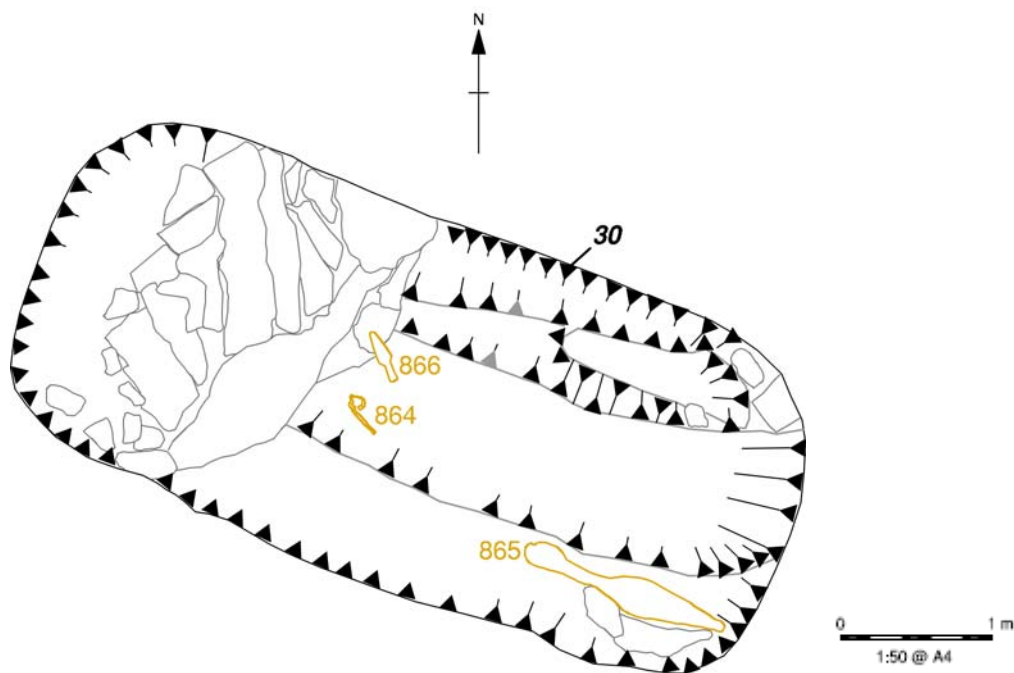


Figure 61: Grave 32 plan © OAN.

Table 4: Grave 32 conservation summary and X-radiograph numbers

SF No.	X-ray No	Material	Object	Notes
864	PI722, P2229	Copper alloy	Buckle	Buckle and decorated counter plate. A double layer plate copper alloy belt buckle. The plates are fragmentary, and the frame is broken into two; the plates have leather remain in between, and organic material on one surface. The two layers have small holes pattern, are joined with 5 rivets.
865	PI699, PI702, PI700, D5180, D5181, D5182	Iron	Spearhead	Large spearhead with wide blade; in 3 fragments. X-ray shows possible iron rivet traversing socket. Slightly blistered and highly mineralised.
866	PI724	Iron	Knife	In two pieces. Iron blade with horn handle. On blade are the possible remains of a leather sheath along with random fragments of plant stems.

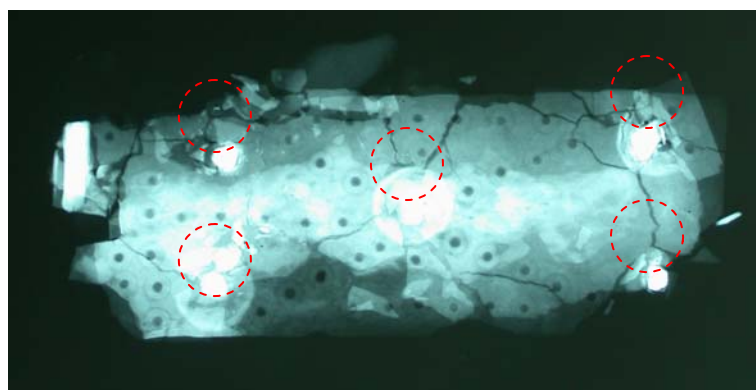


## Grave 32 Buckle SF 864

Copper alloy buckle and decorated counter plate, with associated mineral preserved organic materials (Fig. 62). The copper alloys are heavily corroded with no metal remaining in the thin plates of the counter plate and the decoration is most complete and clearly seen in the X-radiograph (Fig. 63) where the ring and dot motifs radiate out from a central copper alloy rivet. The decorated top plate and plain metal back plate are fixed to the leather belt by five copper alloy rivets, probably with domed heads but none have survived intact. On the front of the counter plate are the remains of a textile (Fig. 64), in a fine tabby weave made from plant fibres (Fig. 65).



*Figure 62: SF 864 Copper alloy buckle with decorated plate (top) and remains of the leather belt still preserved on the underside of the plate (bottom).*



*Figure 63: SF 864 X-radiograph of the buckle-plate illustrates the ring and dot decoration and the approximate position of the five rivet heads marked in red.*



Figure 64: SF 864 Textile on front of buckle plate.

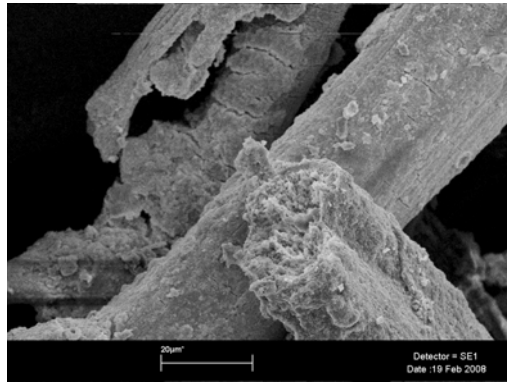


Figure 65: SF 864 Electron micrograph of plant fibres.

### Grave 32 Spearhead SF 865

Large spearhead in three fragments with a wide blade, although the shape is slightly distorted by corrosion blisters (Fig. 66). The X-radiograph shows a possible iron rivet traversing socket. Wood preserved in the socket identified as ash (*Fraxinus* sp.).



Figure 66: SF 865 Iron spearhead in three fragments.

### Grave 32 Iron knife SF 866

Iron knife with layers of mineral preserved organic materials (Fig. 67). On the tang are the traces of a horn handle and on the blade are the possible remains of a leather sheath, with textile preserved on top of the leather on one side along with random fragments of plant stems on the other.

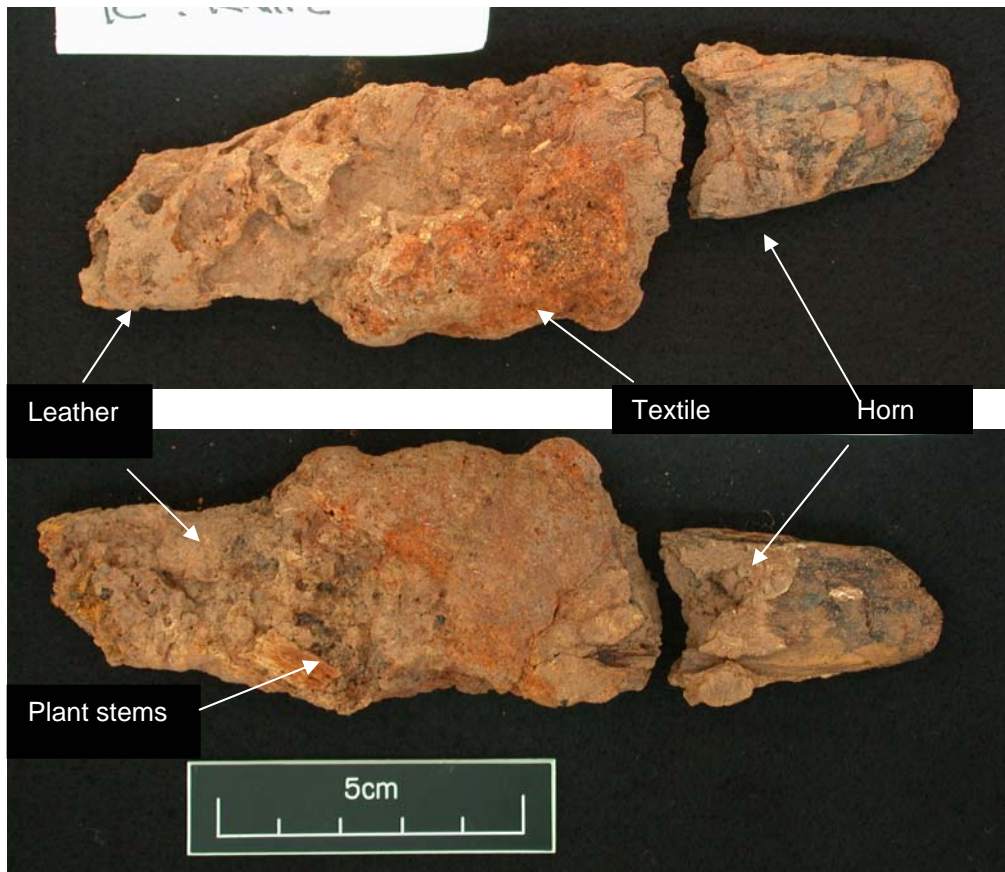


Figure 67: Iron knife with mineral preserved organic materials.

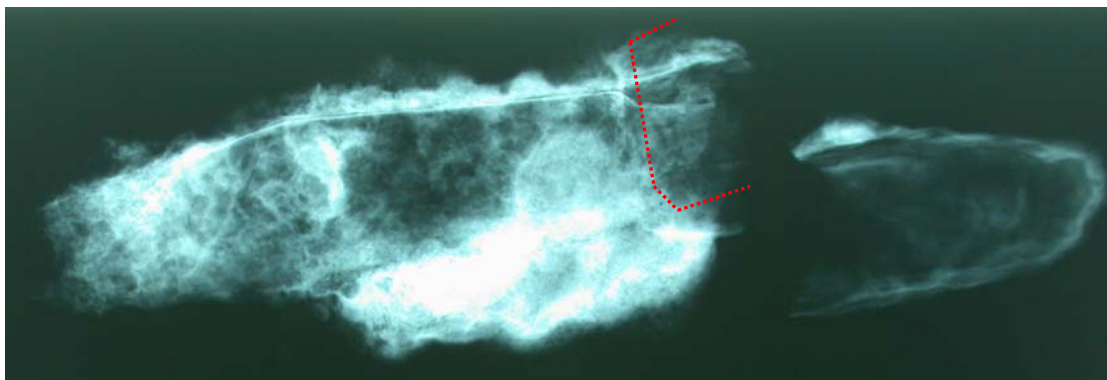


Figure 68: X-radiograph of iron knife with broken tang, the approximate position of the horn handle is outlined in red.

The X-radiograph (Fig. 68) illustrates the outline of the knife blade and tang, and it is also possible to see that the organic handle extends below the shoulder of the blade by a few millimetres.

## GRAVE 36

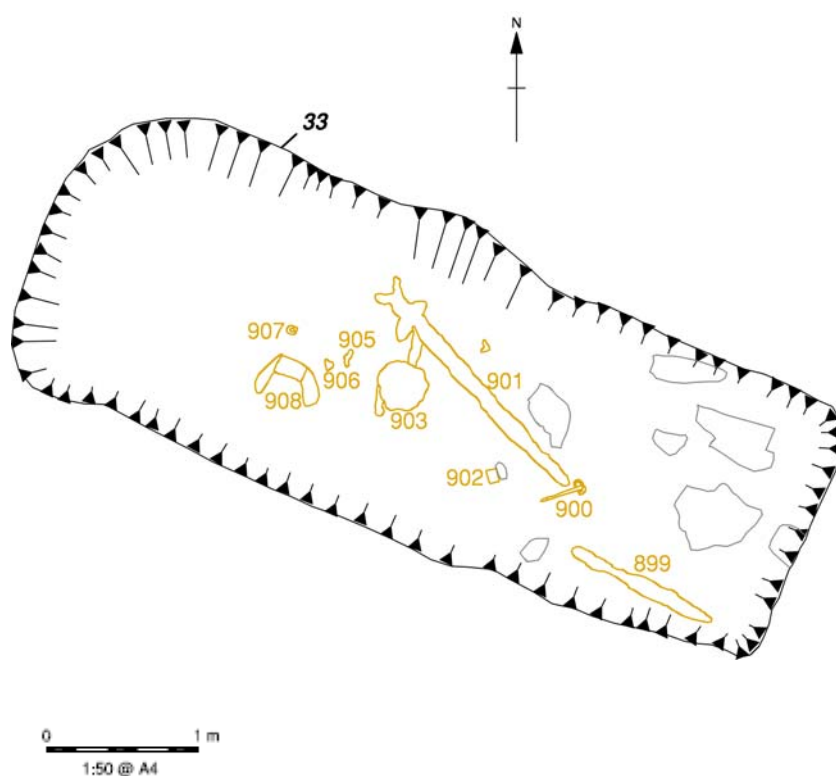


Figure 69: Grave 36 plan © OAN.

Table 5: Grave 36 conservation summary and X-radiograph numbers.

SF No.	X-ray No	Material	Object	Notes
899	PI703, PI728, PI979	Iron	Spearhead	Iron Spearhead, with a surface heavily corroded. A mineral preserved wood on the lower part of the spearhead, which could be either an evidence of the wooden shaft or an evidence of wooden object buried next to the spearhead. Wood: <i>Fraxinus</i> sp. (ash).
900	PI729	Copper alloy	Ring-pin	The ring-pin includes a long pin with a broken pointed needle and a kink or swelling into the shaft attached to a plain and annular ring. Mineral preserved textile on the pin.
901	PI756, PI757, PI758, PI917, PI941, PI942	Iron	Sword	Pattern welded sword in three pieces. Mineral preserved wood (SEM B896), leather and textiles are wide spread all over the sword surface.
902	PI793, PI794	Copper alloy	Sheet	Decorated sheet Seems to be a part of 908.

SF No.	X-ray No	Material	Object	Notes
903	PI756 to 1758, PI872, PI874, PI878, PI879, PI893, PI898, PI899, PI900, PI901, PI903, PI904, PI905	Iron	Boss	Hemispherical boss, the dome is a quite thick while the flange is thinner.
904		Iron	Nail	
905		Iron	Object	Seems to be associated with mineralised organics.
906		Flint	Flint.	Triangular
907		Glass	Bead	
908	PI973, PI980	Copper alloy	Buckle	Mineralised organics preserved textile.
1006	PI745, PI791, PI802, PI803, PI804, PI805, PI806	Iron	Axe	Large axe with wooden handle: <i>Buxus</i> sp. (box). A mineral preserved wood also on the cutting edge.
9063		Iron	Nail fragments	

### Grave 36 Iron spearhead SF 899



Figure 70: Iron spearhead SF 899.

Iron spearhead, with a heavily corroded surface (Fig. 70). A mineral preserved wood on the lower part of the spearhead could be either evidence of the wooden shaft or evidence of a wooden object buried next to the spearhead. Wood: *Fraxinus* sp. (ash) from mature timber (Fig. 71).

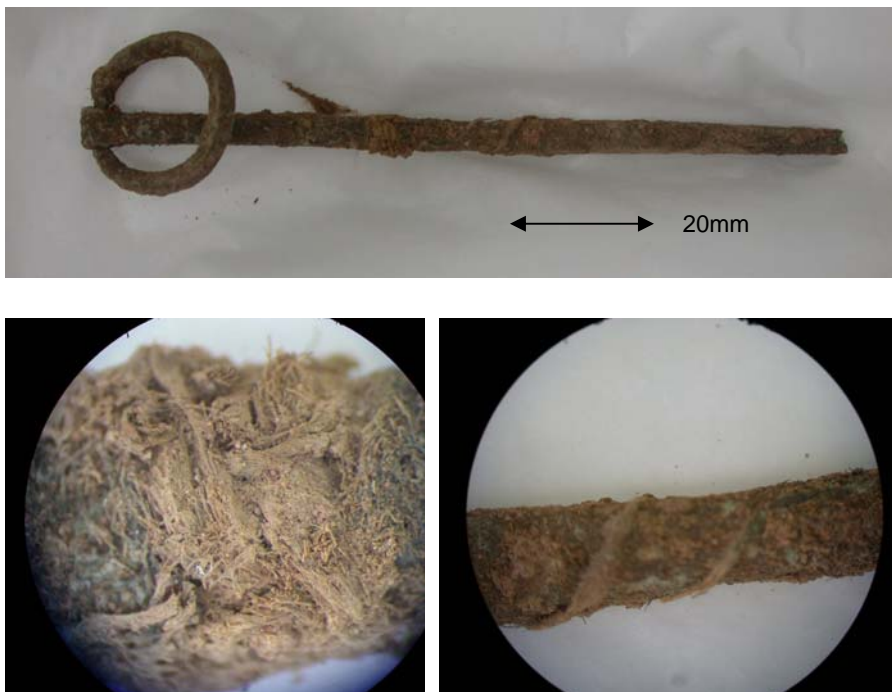


Figure 71: SF 899 Cross section of mineral preserved wood in spearhead socket.



### Grave 36 Ring-pin SF 900

Copper alloy ring-pin in good condition with textiles fibres preserved in two places along its length (Fig. 72).



*Figure 72: SF 900 Copper alloy ring pin and details of the textile fibres.*

### Grave 36 Sword SF 901

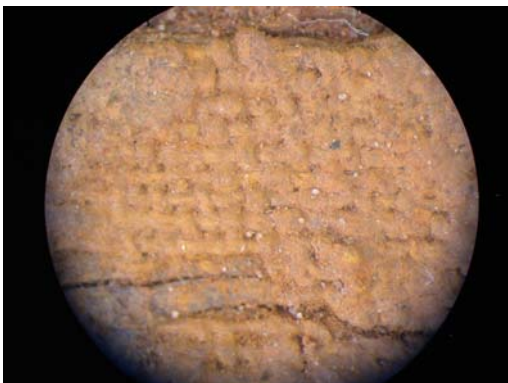
Sword SF 901 and shield boss SF 903 lay side by side in the grave and were lifted together in a soil block. The sword was in fragments and in places distorted by large corrosion blisters (Fig. 73). X-radiography revealed evidence of construction and pattern welding (Fig. 74) Mineral preserved leather, wood and textile (Fig. 75) from the scabbard are preserved on both sides of the blade. White organic material preserved along one side of the tang, suggest that the grip was made from bone or antler.



*Figure 73: SF 901 Both sides of sword hilt after conservation.*



*Figure 74: SF 901 X-radiograph of sword hilt clearly illustrating the form of the upper and lower guards and part of the pattern welded blade*



*Figure 75: SF 901 Textile lining from the scabbard preserved on the blade.*

### **Grave 36 Shield boss SF 903**

Small shield boss with a very narrow flange (Fig. 76). It is not clear even in the X-radiograph how it was attached to the shield board (Fig. 77). On the underside of the flange are areas of mineral preserved wood and textile from the shield board (Fig. 78).



Figure 76: SF 903 Heavily corroded shield boss as excavated from the soil block.

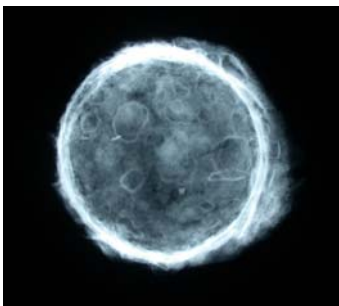


Figure 77: SF 903 X-radiographs in plan and side view.

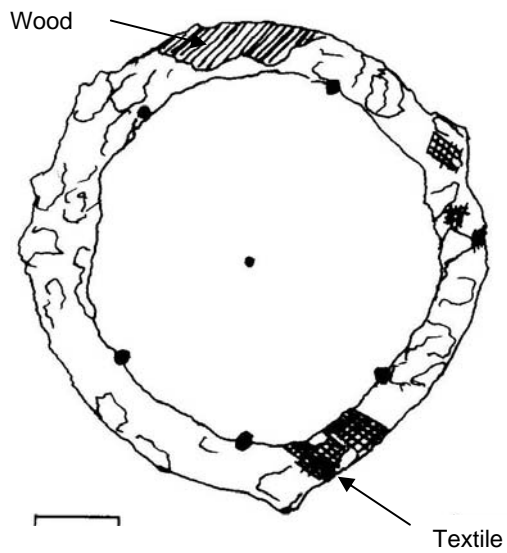


Figure 78: SF 903 Mineral preserved organic material on underside of flange.



### Grave 36 Iron object SF 905 and flint SF 906

Small iron object covered in mineral preserved organic material, and found close to a triangular shaped flint and could be the components of a basic fire-lighting kit (Fig. 79).

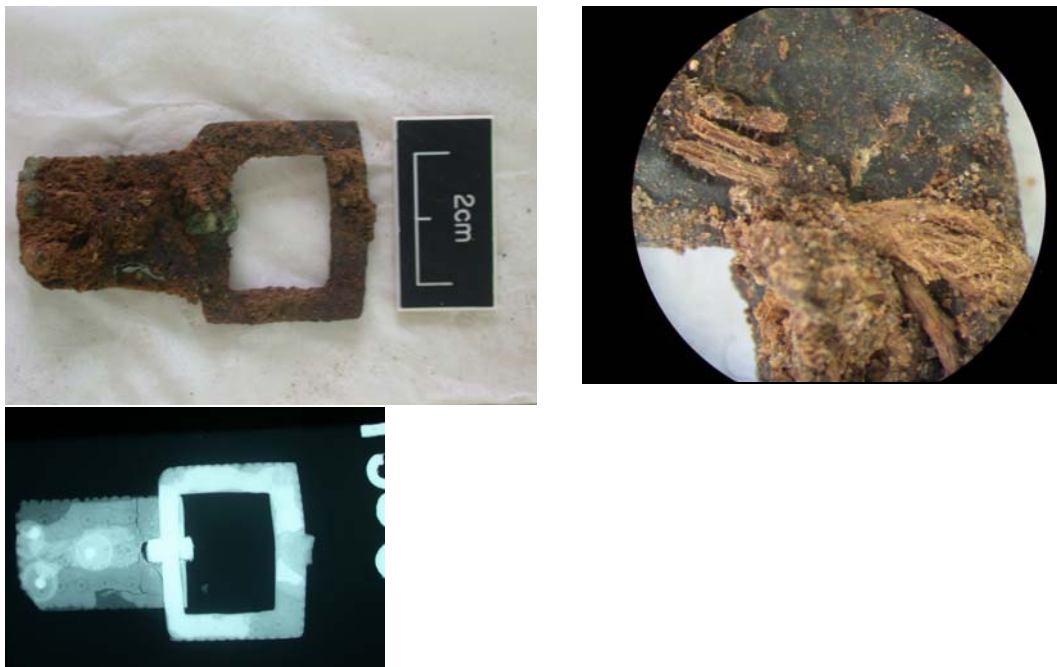


*Figure 79: Possible striker (SF 905) and flint (SF 906) from a fire-lighting kit.*

### Grave 36 Bead SF 907

One bead was found in this grave. The bead is dark coloured glass with white round decoration incorporated into it. It also has decorative carvings. No evidence for a bead string was found.

### Grave 36 Buckle SF 908 and Strap end SF 902



*Figure 80: Buckle SF 908, X-radiograph showing the position of the rivets, and detail of the fibres wrapped around the buckle loop.*

SF 908 copper alloy buckle and plate (Fig. 80) with SF 902 strap end (Fig. 81). They are very thin and fragile which has resulted in some of the edges breaking during the removal of soil and loose corrosion aimed at revealing the decoration (Fig. 82). The buckle has mineralised organic remains of textile (Fig. 80). XRF analysis indicated that the surface was originally tinned.

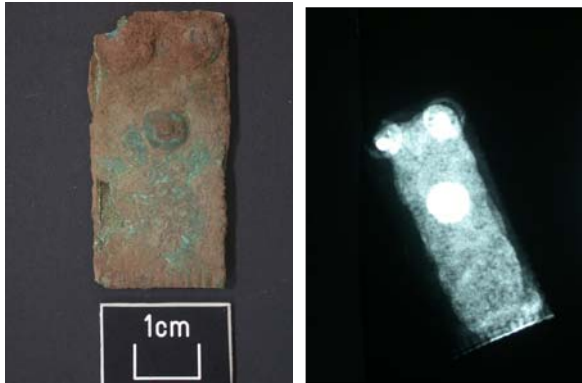


Figure 81: Strap end SF 902 and X-radiograph illustrating rivets and decoration.

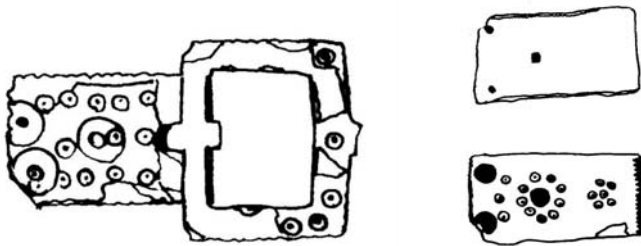


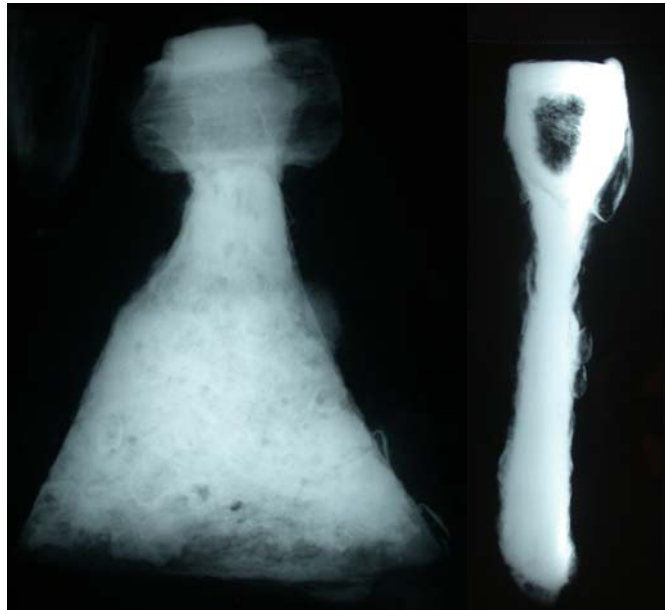
Figure 82: Decoration on the buckle (SF 908) and strap end (SF 902).

### Grave 36 Axe SF 1006

Large iron axe found underneath spearhead SF 899 in a soil block (Fig. 83). This substantial piece has the remains of its wooden handle in the tapered socket (Fig. 84), which was identified as *Buxus* sp. (box). Wood was also found preserved on the blade edge as if it was some type of protective guard (Fig. 85), but this was found to be oak (*Quercus* sp.) which might mean that it was embedded in a large piece of wood possibly even the grave wall?



*Figure 83: Large axe SF 1006*



*Figure 84: SF 1006 X-radiographs of axe illustrating the outline and shape of socket*



*Figure 85: SF 1006 Wood preserved on the edge of the axe blade.*

## GRAVE 85

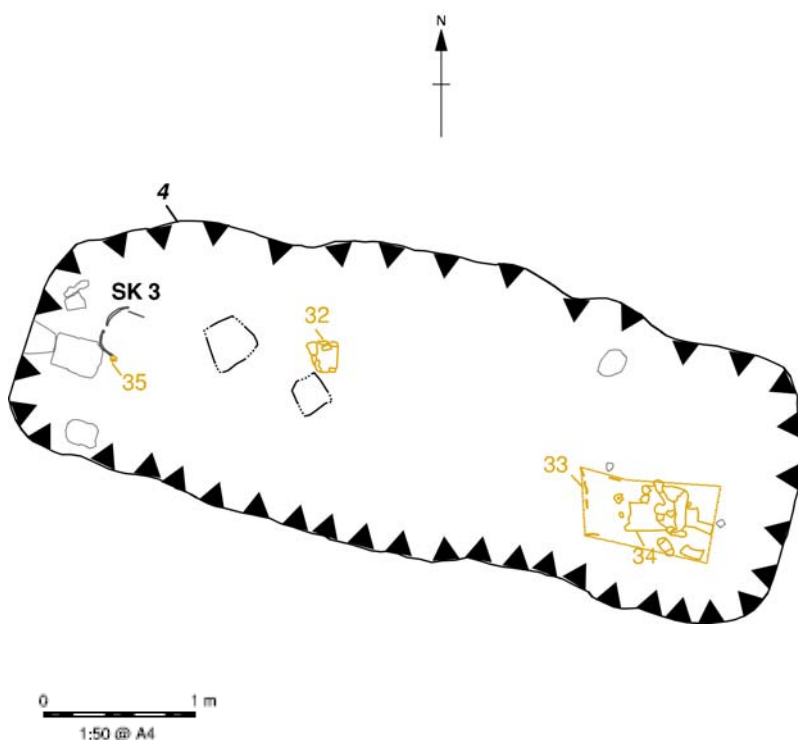


Figure 86: Grave 85 plan © OAN.

Table 6: Grave 85 conservation summary and x-radiograph numbers.

SF No.	X-ray No.	Material	Object	Notes
1	PI705	Copper alloy	2 tortoise brooches	2 gilded tortoise brooches, with iron preserved textile on both.
32	PI764	Iron	Possible knife handle	Inlaid with silver wire.
33	PI748a,b, PI751, PI752	Iron	Iron bound wooden box with contents.	
	PI748a,b, PI751, PI752	Glass	Linen smoother	Made from potash glass.
	PI748a,b, PI751, PI752	Iron	Shears	Shears with most of the antler comb preserved in the corrosion layers.
	PI748a,b, PI751, PI752		Needles	Possibly in a case
	PI748a,b, PI751, PI752	Lead	Spindle whorl	
			Iron	Rivets

SF No.	X-ray No.	Material	Object	Notes
34		iron	Object	From inside box.
35		glass	Bead	Translucent
9050	PI764, PI765	iron		26 fragments with mineral preserved wood, mostly fragments of box strapping and a key.
9051	PI764			12 fragments with mineral preserved wood.

### Grave 85 Tortoise Brooches SF I



*a. Brooch A, front.*



*b. Brooch B, front.*



*c. Brooch A, reverse.*



*d. Brooch B, reverse.*

*Figure 87: SF I The two tortoise brooches before conservation.*

The two tortoise brooches (in the following referred to as Brooch A and Brooch B) are of the same design. Both brooches are moderately corroded (Fig. 87a & b) and fine surface details are obscured. The lattice work decoration is however still recognisable through the corrosion. Gilding is visible in some places on the front of both brooches. Closer examination under the stereo microscope shows that protruding areas are abraded, surface loss has occurred here and an uneven, dark red surface is now visible. The pin itself, quite likely made of iron, has not survived. Iron staining can be found on the back of both brooches, especially around the pin hinges and curled-over catch plate (Fig. 87 c & d). Mineral preserved organic remains are located around the pin hinges. The



space underneath the lattice work and the mineral preserved organics are covered in loosely adhering sediment.

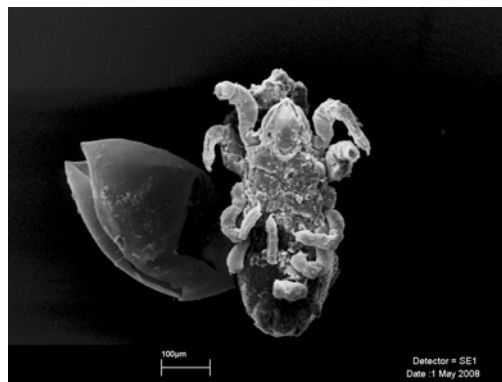
The brooches were analysed using XRD, XRF and FTIR. A detailed report can be found in Appendix A.

### Insect Remains

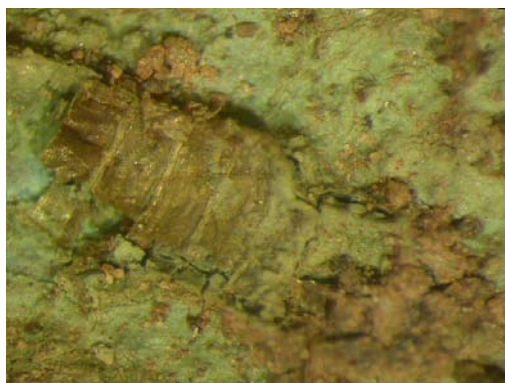
During the removal of loose soil surrounding the textile, insect remains were found (Fig. 88a). These were collected and examined using the SEM (Fig. 88b). Additionally pupa cases preserved in the corrosion products on the reverse and the imprints of insect bodies preserved in the corrosion products on the front could be observed (Figs. 88c and d). An identification of the insect remains was carried out by Harry Kenward of York University. According to H. Kenward most of the individuals collected are mites (*Acarina*), there is one chelicera of a false scorpion (*Pseudoscorpione*) and one possible louse, but identification in this case is not conclusive.



*a. Insect remains from back of Brooch A.*



*b. Mite (*Acarina*) under SEM examination.*



*c. Pupa case impression in the corrosion products, Brooch A, back.*



*d. Insect body in corrosion products, Brooch A, front.*

*Figure 88: SF 1 Insect evidence found in the corrosion on the brooches*

The insects provide an interesting insight into the decay pattern of this grave. Pupa cases as impressions in the corrosion were only found on the reverse. But insect impression of

deceased bodies could be observed on the front only. This indicates that breeding took place on the reverse and after hatching the insects spread over the whole brooch, where they eventually would cease and became encased in the corrosion products.

### Fibres

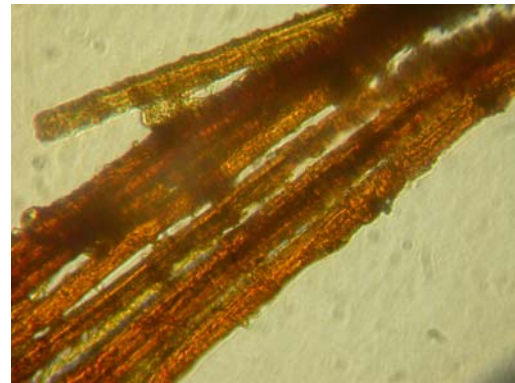
One textile fragment on the reverse of brooch A was loose and available for analysis (Fig. 89). The weave was identified as plain weave, from probably a Z-spun yarn. The fibre was identified as a bast fibre (such as flax (linen) or hemp), see Figs 90a and b. Besides the textile remains on both brooches the impression of felt or hair was observed near the catch plate of brooch B (Fig. 91).



*Figure 89: SF 1 Textile fragment from reverse of Brooch A.*



*Figure 90SF 1 a Bast fibre.*



*b Bast fibre.*

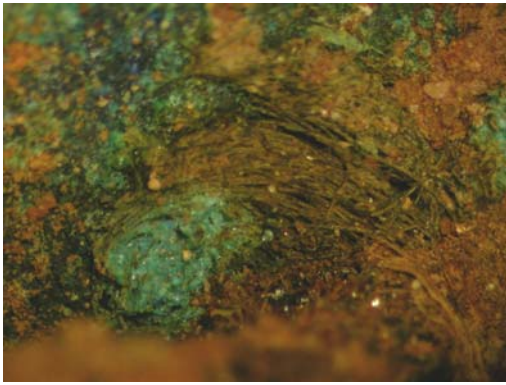


Figure 91: SF I Preserved hair on reverse of Brooch B.

### Construction

Both brooches consist of three individual segments: the border, the face plate and a backing plate. The individual fragments were probably soldered together. The state of preservation did however not allow for further analysis here. An additional connection was however made by the rivets of the bosses. The hole for the rivet in the boss is duplicated by a hole underneath it in the backing plate. In one instance the rivet has survived and protrudes past the backing plate, where it is secured with a little piece of metal (Fig. 92).

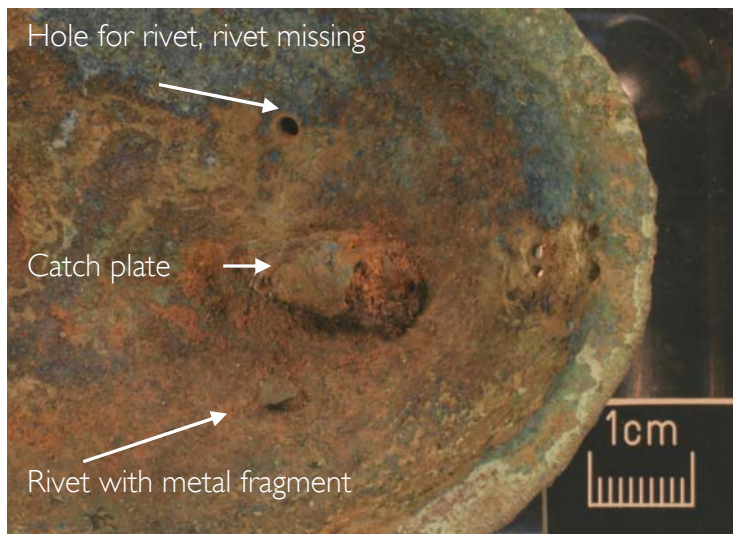


Figure 92: SF I Back of Brooch A, hole through back plate and rivet with metal fragment in back plate.

The metal of the brooches was identified as a copper-zinc alloy, brass. All three segments were gilded, including the backing plate underneath the lattice work. No traces of mercury were found. The border is divided into 8 long fields. Each field is again separated by 8 small fields of a white metal, which taper towards the top. These small fields differ in terms of the decoration (these fields display a geometric pattern, while the rest of the brooches are decorated in a woven band pattern), and composition as they are a lead-tin



alloy. Holes could be observed around these 8 small fields (Fig. 93a). The function of these holes could not be determined. A peculiar colouration on the back of Brooch A around these holes (Fig. 93b) gives reason for the assumption that something was attached to the back of the brooch, using the holes as points of fixture.



Figure 93a: Brooch SF I A front, holes around fields.



b: Brooch SF I A back, colouration around holes.

The four bosses on the face plate of each brooch are empty. However, the rivets and the soldering material are preserved in most cases (Figs 94a and b). The solder was identified as a lead-tin alloy. It can only be speculated as to what the decoration on these bosses might have been. Considering the very poor preservation potential of calcareous materials on site, it might have been bone, antler or shell.

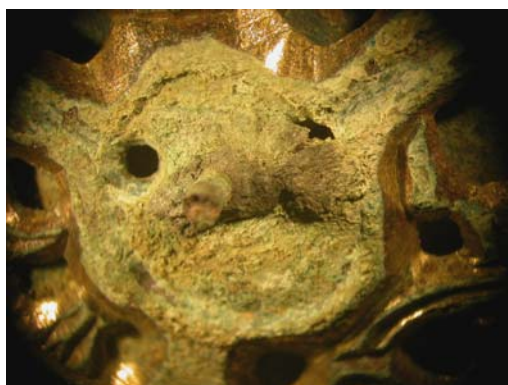


Figure 94a: SF I Boss with rivet and black soldering material, Brooch A.



b: SF I Rivet with black soldering material, Brooch A.

The fronts of the brooches are dominated by two diamond shapes. The four corners of each diamond connect two empty bosses with two protruding bosses and by doing so creating a connection to the central protruding boss. The diamond is formed by linear channels. No gilding could be found inside the channels. In a similar example of tortoise brooches it was suggested, that a precious metal such as silver might have been prevalent in these channels (Welander *et al*/ 1987, 154). Of interest are the holes at either end of

the channels, which might have provided a loop for a silver wire to be fed through to the next channel. But this has to remain speculation.

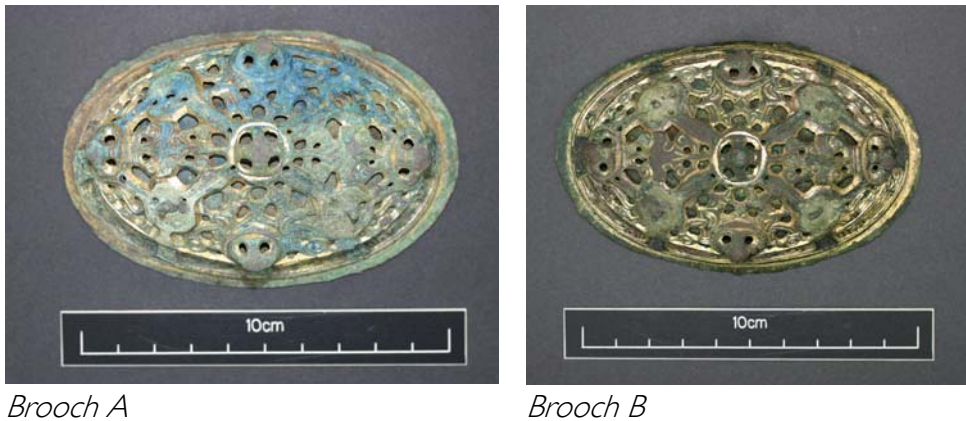
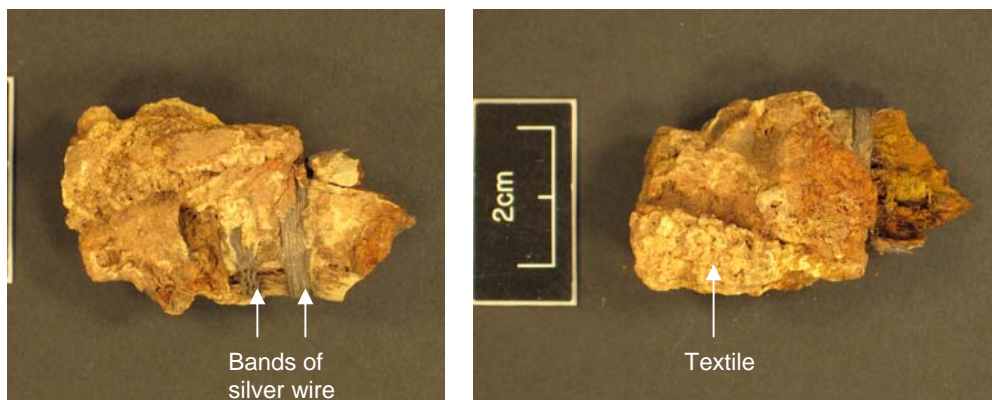


Figure 95: SF 1 Brooches after conservation.

### Grave 85 Knife handle SF 32

Broken iron knife tang with remains of a decorated wooden handle made from *Fraxinus* sp. (ash), fashioned from mature timber and bound or inlaid with silver wire (Fig 96a). Folds of mineral preserved textile are located on the top of the handle (Fig. 96b).



a. Knife handle illustrating the two sets of silver wire. b. Folds of textile on top of the handle.

Figure 96: SF 32 Knife handle.

### Grave 85 Box and contents SF 33

Box made from *Acer* sp. (maple), trapezoid in shape with decorated iron fittings (Fig. 97). Dimensions: Width 380mm at top, c.460mm base; height 200mm with feet c.20mm; the depth is less certain as the block appears to be compressed, but is probably between 110-160 mm. The box is basically made from a base comprising 5 pieces of wood, with a

lid made from a single piece carved into shape, and onto this basic shape ironwork in the form of a lock, hasp, hinges, two types of corner bracket, and narrow strapping have been added. As a significant amount of wood has been preserved on this ironwork, it has been possible to reconstruct what the original box might have looked like (Fig. 106).

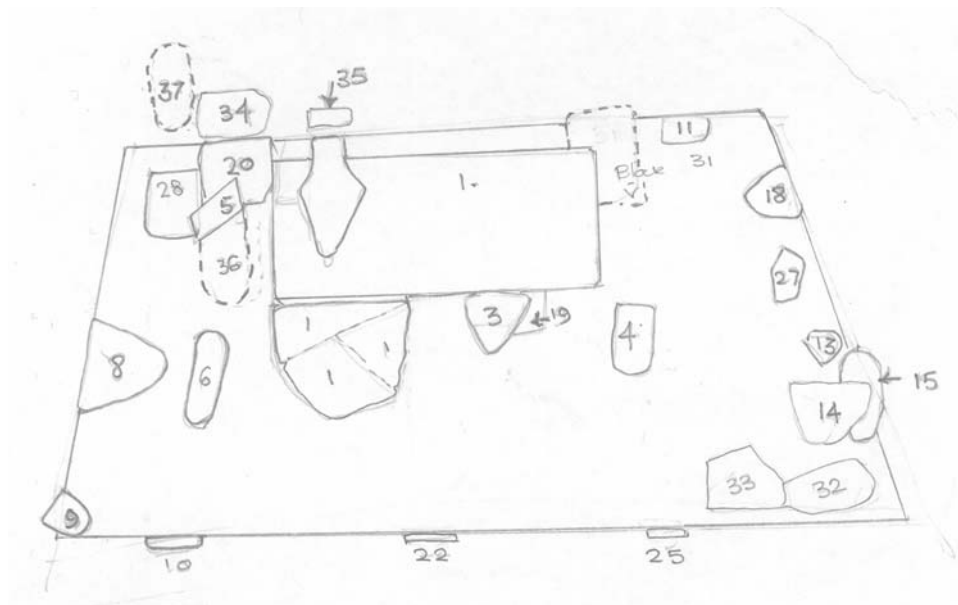


Figure 97: Plan of metalwork (numbered) that was originally attached to the front of the box.

#### Grave 85 Box: Lock plate and hasp

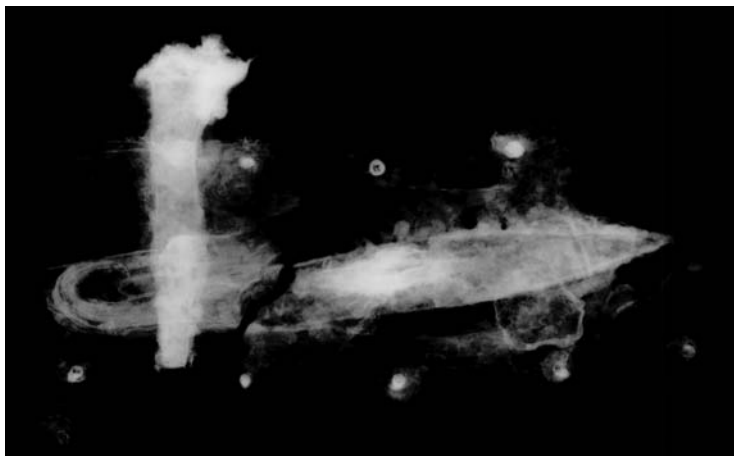


Figure 98: X-radiograph of lockplate, with hasp and lock mechanism.

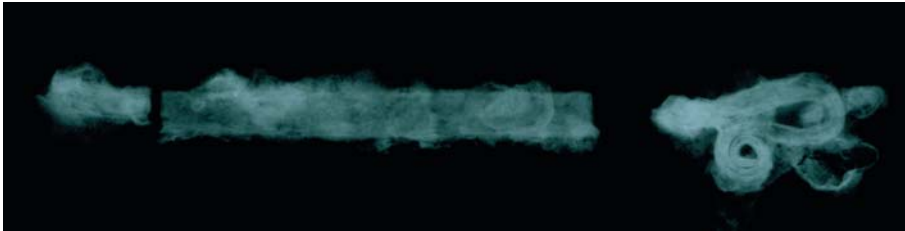
The lock plate was originally decorated and rectangular in shape, and attached to the front of the box with eight short nails. Positioned just below it were three triangular mounts, with their apex lowermost. The hasp was secured by a sliding bolt with a leaf-shaped

spring, and the lock mechanism can be seen in the X-radiograph (Figs. 98 and 99). Strangely, as a key was found in this grave, there appears to be no sign of a keyhole, so it is difficult to work out how the lock mechanism worked.

A substantial amount of mineral preserved wood remains attached to the lockplate and hasp, which indicates the shape of the lid and the minimum thickness of the front of the box. This also provides evidence that the front of the box was made from a board with a radial surface (RLS), and the grain aligned horizontally.

### **Grave 85 Box: Hasp or handle fragment**

Close to the lockplate was a crook-headed strip attached to the box by a loop-headed pin, along with two other fragments (Fig. 99). These could be the remains of the second hasp required to secure the lid to the front of the box or could be parts of a broken drop handle.



*Figure 99: X-radiograph of hasp or handle fragments.*

### **Grave 85 Box: Corner brackets with rebate**

The corner brackets on this box give a clear indication of the type of carpentry joints used to join the sides together. Rebated butt joints have been used where rebates of c.4mm have been cut into the front and back boards to hold the side boards in position while securing them with glue or dowels. The brackets have then been applied with either short-stemmed nails or longer ones with the tip folded over on the inside of the box. The preserved wood also indicates that the side boards were used with their grain running vertically.

Corner bracket <8> is the most complete example and details of the wood grain and the rebated joint reconstructed from this evidence can be seen in figures 100, 101 and 102.



Figure 100: SF 33 Corner bracket <8> with rebate to take side board (plan and side view).

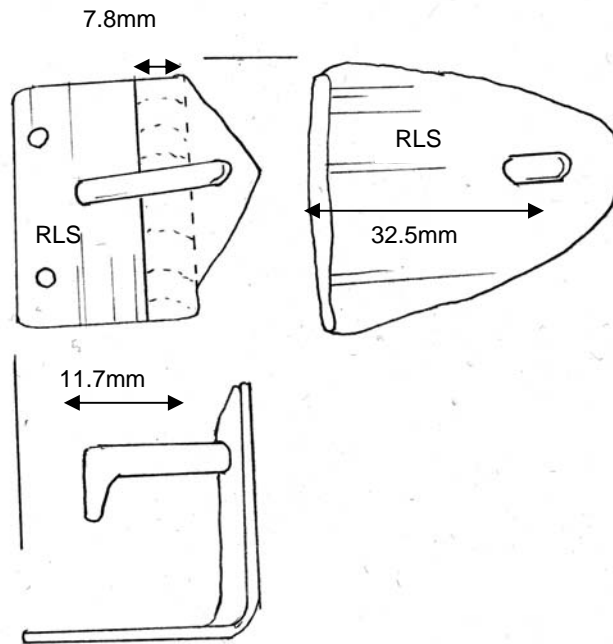


Figure 101: SF 33 Wood grain preserved on corner bracket <8>.

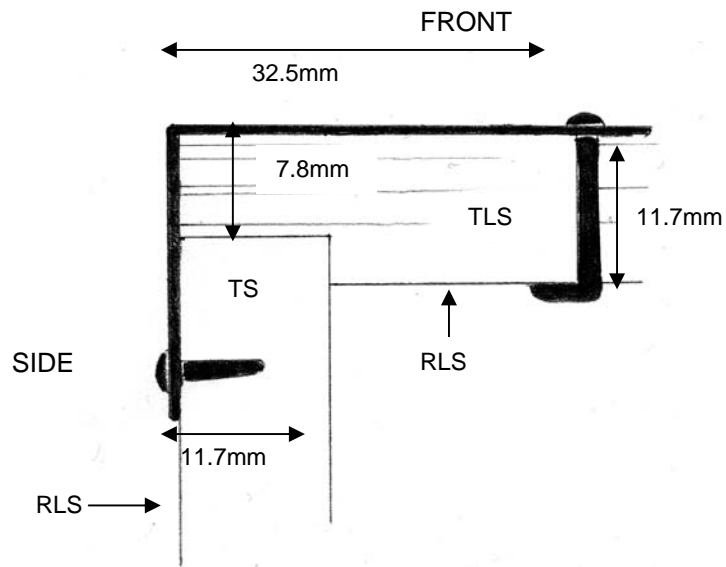
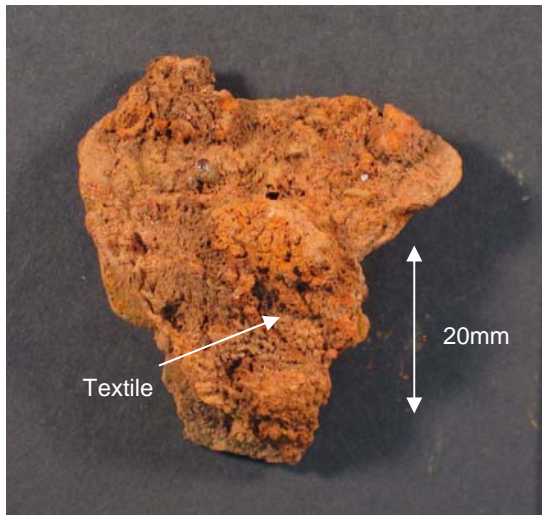


Figure 102: SF 33 Reconstruction of rebated joint preserved on corner bracket <8>.

#### Grave 85 Box: Hinges SF 9051 and <34>

The two hinges from the back of the box clearly illustrate the curvature of the lid and that it has been carved from a single piece of wood (Fig. 103). Both hinges are covered in layers of textile, which may mean that the box was wrapped before placing in the grave, or the floor of the grave was lined with textile.





*Box fitting SF 9051*



*SF9051 Side view*



*Box fitting <34>*



*<34> Side view*

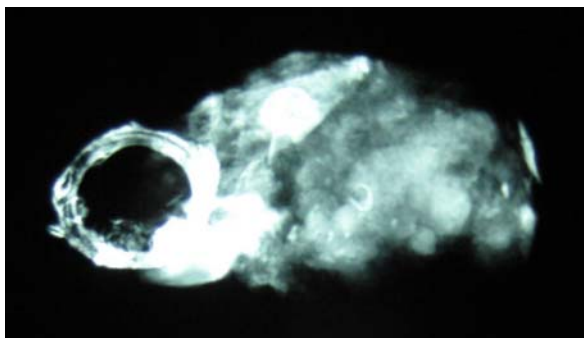
*Figure 103: The two hinges used to attach the lid to the back of the box; both have significant amounts of wood and textile preserved on them.*

### **Grave 85 Box: Ring mounts on the lid and side**

Two iron rings were found during the dismantling of the soil block, and both had originally been attached to the wooden box by means of loop headed pins, so that the ring could freely move. The ring on the lid (<block V>) was positioned above the narrow iron band that went all the way round the box, and the other appears to have been attached to a triangular mount on the side (<17>).



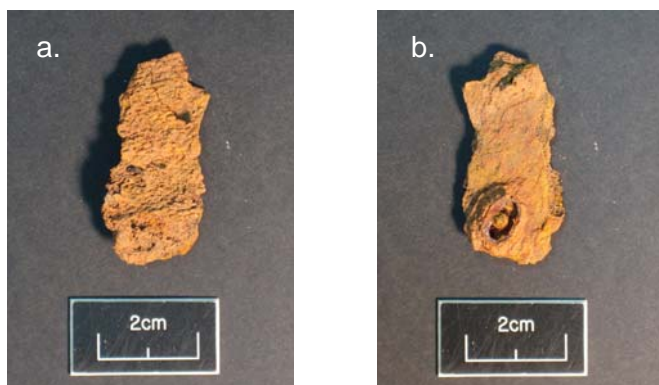
Neither ring appears to have been substantial enough to take the weight of the box and contents so are unlikely to be handles as such, although one could have been used to lift open the lid. It is also strange to have a ring mounted only on one of the sides, maybe there was a third ring originally but this has either been lost or was so badly corroded it was not recognised when deconstructing the block.



*Figure 104: X-radiograph of ring attached to iron binding on box lid.*

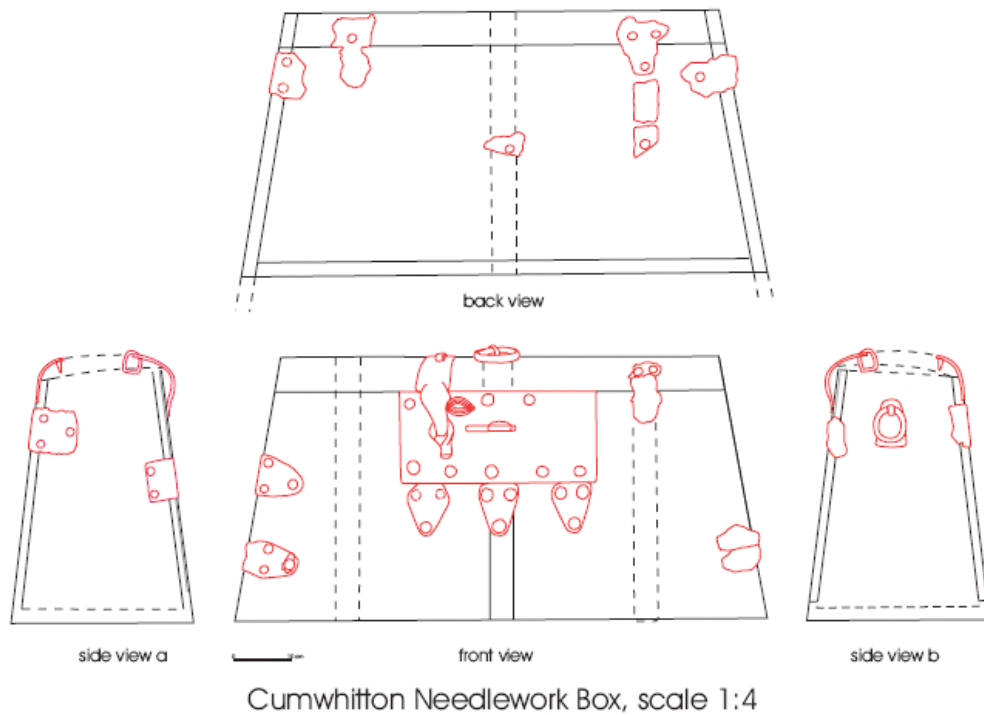
#### **Grave 85 Box: Narrow iron straps**

Many fragments of thin iron strapping, c. 21 mm wide, were located during the deconstruction of the soil block. All had mineral preserved wood on one side, which made it possible to orientate the piece with grain direction of the wooden side it was mounted on, and many also had textile preserved on the outer surface (Fig. 105).



*Figure 105: Iron strap fragment from exterior of box with textile (a) preserved on outside, and wood (b) on inside.*

Enough of this strapping was found to presume that it belonged to three bands that extended from the lid round to the front of the box (Fig. 106). This elaborate binding may have been additional fastening to hold the box together. This might be needed if the joints were just glued together rather than fixed with dowels or nails.



*Figure 106: Reconstruction of the wooden box with iron furniture.*

### Grave 85 Box contents

When buried this box was quite likely to be full of the tools required for various textile work. The position of the items that were found suggest that they were tightly packed in the box so that they would not move much when the box was placed on its back in the grave (Fig. 107). However, the burial conditions at Cumwhitton mean that only metalwork and some glass remain, albeit in a poor condition. Items made from organic materials are only preserved where they were in contact with metal, so this needlework box could have contained many more items of which no trace survives.

The following items were found (Fig. 107): glass linen smoother or slick stone (A), iron shears (B), iron rivets from a composite antler comb (C), lead spindle whorl (D), hollow cone-shaped iron object (E) and iron needles (F).

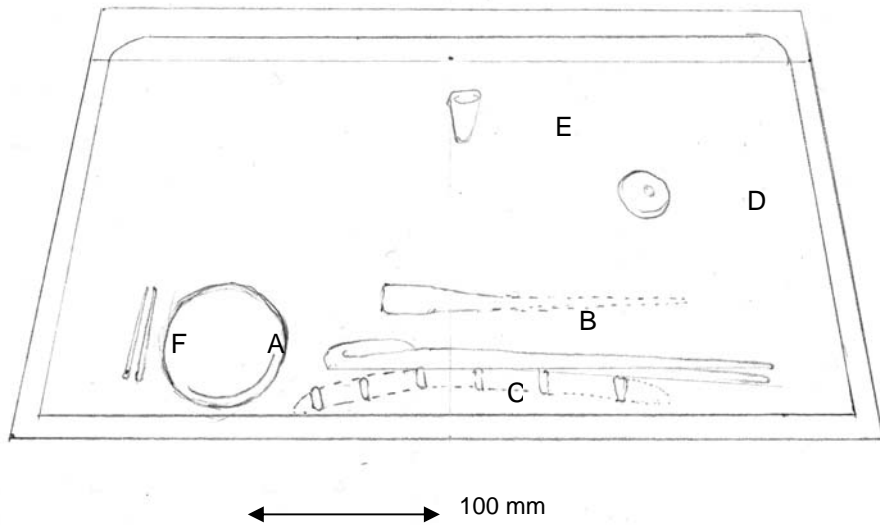


Figure 107: Box with the approximate position of contents. A: linen smoother or slick stone; B: shears; C: comb; D: spindle whorl; E: iron object; F: needles

**Grave 85 Box: <A> Glass linen smoother or slick stone**



Figure 108: SF 33 A Glass slick stone.



Underside with attachment point for handle.

Glass linen smoother, made from potash glass, when first exposed and still damp was a blue colour and had a wax like texture. On drying it discoloured to a cloudy brown, with a very friable surface (Fig. 108). XRF analysis showed that it was made from wood-ash glass which is very unstable in acid environments and accounts for the dramatic change it underwent on drying. Also the absence of metal compounds often used to colour or stabilise the glass means that it was not clearly visible on the X-radiograph of the soil block of the box contents, in fact one had assumed that the dark circular area might be jet bangle as this material is also X-ray transparent.

No recognisable trace was found of an organic smoothing board to go with this slick stone, although there was space for one in this box. Again the acidic conditions would not favour the preservation of such an object.

#### **Grave 85 Box: <B> Iron Shears**

The shears were located as heavily corroded fragments within the soil block, so it is not clear whether there were two pairs or just one large pair as it was impossible to repair most of the pieces. Corroded onto the blades are several of the iron rivets and part of the side plates of a composite antler comb (Fig. 109).



*Figure 109: SF 33 B Iron shears with fragments of an antler comb preserved on the blades, and the bow of another pair of shears.*

#### **Grave 85 Box: <C> Composite Antler comb**

All that remains are five, possibly six, iron rivets on or near the large iron shears and on these rivets are layers of mineral preserved antler that correspond to the teeth and side plates of the original comb (Fig. 117). However, not enough remains to suggest the original form of this comb.

#### **Grave 85 Box: <D> Lead Spindle whorl**

Pierced lead object, flat on one side and dome-shaped on the other resembles a spindle whorl and is made of almost pure lead (Fig. 110). No evidence of what it might have been attached to survives.



Figure 110: SF 33 D Lead spindle whorl – *Upper side*      *Underside*

#### Grave 85 Box: <E> Iron object

This iron object was found near the lid of this box, and resembles some type of ferrule. No organic material was preserved inside the socket that might have given some indication of what it was attached to or used for.

#### Grave 85 Box: <F> Iron needles

At least two iron needles were visible on the X-radiograph of the needlework box, but only the broken points could be found among the contents when the soil block was excavated. The needles were on the base of the soil block. It is likely that they were c.60mm long with the eye of one c.2mm in diameter (see Fig. 111).

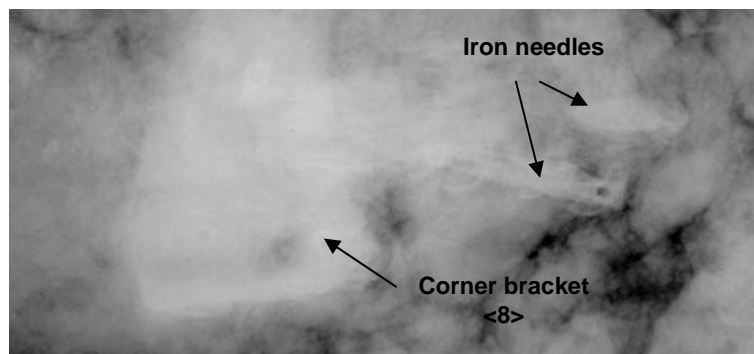


Figure 111: Needles visible in X-radiograph of needlework box.

The position of the two needles suggest that they might have been in a needle-case, but only a few slivers of wood were found nearby of maple or lime which could also have come from the main box.

## VIKING METALWORK FROM PLOUGH SOIL

*Table 7 Viking metalwork from plough soil conservation summary and x-radiograph numbers.*

SF No.	X-ray No.	Material	Object	Notes
29	PI829, PI833	Iron	Sword hilt	Handle nearly detached. MPO wood on blade and cross braces SEM B885 Wood SEM B886 Leather
31	PI828	Iron	Knife	
311		Iron	Spearhead	
402	PI984	Iron	Fragments of sword blade	SEM B888 Wood SEM B889 Leather
404	PI833	Iron	Knife	
405	PI984	Iron	Fragments of sword blade	SEM B888 Wood SEM B889 Leather
409	PI828, PI833	Iron	Fragments	SEM B890 Wood , leather?
634		Iron	Object	

### Plough soil Sword hilt SF 29



*Figure 112: SF 29 Both sides of the broken sword hilt.*

An almost complete sword hilt, along with the top part of the blade encased in fragments of the original scabbard. The hilt comprises a curved metal upper and lower guard, but the pommel is missing (Fig. 112). The grip appears to be bone, but only traces remain on the exposed tang so it is not possible to suggest the original shape. The overall length of the hilt is c.77mm.



Traces of the composite scabbard are preserved on the sword blade and it is possible to see the different layers of textile, wood and leather. Wooden stiffener made from *Salix sp.* (willow) or *Populus sp.* (poplar).

### Plough soil Iron knife SF 31

Iron knife tang with traces of a bone handle preserved along its length.

### Plough soil Iron spearhead SF 311

Spearhead with mineral preserved wood in the socket, *Fraxinus sp.* (ash) and made from mature timber.

### Plough soil Fragments of sword blade SF 402 and SF 405

Remains of the composite organic scabbard have been preserved along these sections of the sword blade and include wood, *Salix sp.* (willow) or *Populus sp.* (poplar) and a possible outer covering of leather.

### Plough soil Iron knife SF 404



Figure 113: Iron knife with fine pleats of textile preserved on one side.

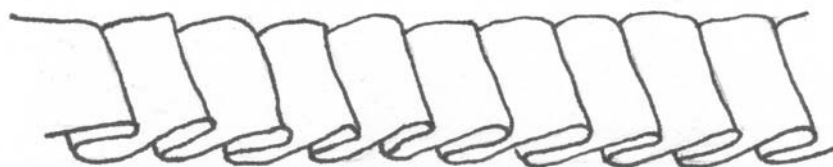


Figure 114: Illustration of the pleated cloth, the distance between the top of two pleats is c.5mm.

Broken knife blade with layers of organic material preserved on one side, which on initial examination appeared to be strips of leather on wood. Closer inspection revealed these to be fine pleats of textile, between 3-5mm wide on top of another layer of textile (Figs. 112 and 113). This textile has a fine and even tabby weave and the pleats are very sharp, so it was probably made from a vegetable fibre. The areas that look like wood are in fact iron corrosion that has taken on a fibrous form following the forging lines produced in the making of the blade.

### **Plough soil Iron fragments SF 409**

Several iron fragments with various organic materials preserved on them, unfortunately it is not clear what these pieces originally were.

### **Plough soil Iron object SF 634**

Possibly an iron knife as there are organic materials preserved along the length of the object that might be the remains of a leather sheath. However these organic layers might just relate to the context that this object was found in.

## **DISCUSSION**

The following discussion provides a general overview of the organic materials and alloys used for specific types of objects:

### **Swords**

There are at least four swords from the site, three of which were found in graves (24: SF 779, 25: SF 880 and 36: SF 901) and the fourth was found in many fragments in the plough soil (SF 29). Despite the damage to these objects from corrosion and ploughing it has still been possible to record the construction of the hilts and scabbards, although the blades are too distorted to look at the pattern welding in any detail.

The hilts are made of several components where all the sections are slotted over the tang and interlock with each other to ensure that there is no movement when used. The Cumwhitton examples have three or four parts: lower guard, grip, upper guard (on three) and pommel, all except for the grips are made in metal and some with decorative inlay. The grips are usually made from an organic material such as horn, bone or antler but this has only been preserved on two SF 29 (bone) and SF 779 (horn).

The composite scabbards found on all four blades appear to be made of the same materials with wooden stiffeners made of *Salix sp.* (willow) or *Populus sp.* (poplar), lined

with layers of plain weave textile, and the whole construction held together with an outer covering of leather in one piece or as strips bound round the wooden stiffeners. According to Cameron (2000, p.59), this is the normal construction for Viking swords. The scabbard on sword SF 29 is slightly unusual in that the wooden stiffener appears to be made from a single piece of wood that only encompasses one side and both edges of the blade (Fig. 115), a construction paralleled in Iron Age swords from North Yorkshire (Watson and Edwards, 1992) where it was thought that this might be a more robust scabbard worn across the back by riders

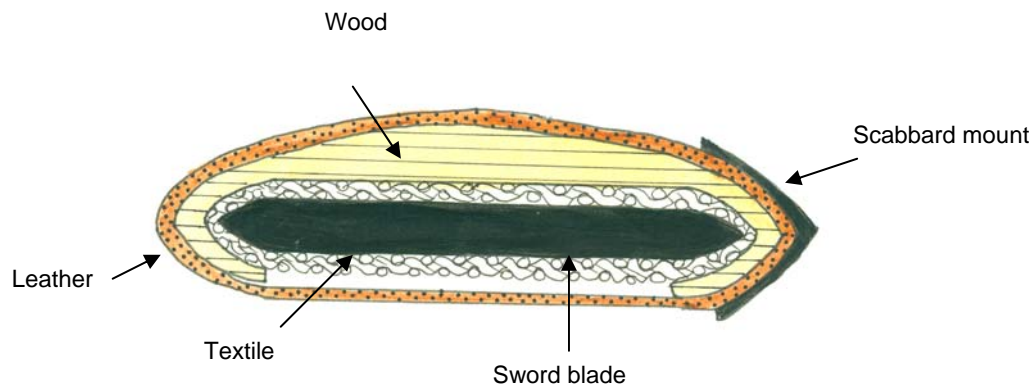


Figure 115: Cross section of sword scabbard SF 29 illustrating the different layers.

## Spearheads

Most of the spearheads have mineral preserved wood remaining in the sockets, where they could be identified, were found to be ash. This is a continuation of the selection of this wood during the Anglo-Saxon period for spear shafts as ash is a flexible wood, and the use of mature timber improves its handling qualities. Ash is a native tree to the British Isles and southern Scandinavia, so it is not possible to identify any imported items on this basis.

## Axe

The battle-axe (SF 1006) was found underneath the spearhead (SF 899) in grave 36. It is hafted with *Buxus* sp. (box), a dense and resilient wood traditionally used for hammers and other tools where the handle has to absorb the impact of hitting hard materials and not snap under the pressure. Box is native to the south of England and parts of north western Europe, and more common in southern Europe, so would not have been readily available in Cumbria at this date (Hather 2000, 78).

Wood is also preserved on the blade edge that may represent a guard. Alternatively, as it is oak, the axe may have been embedded into the grave structure or some other piece of timber.

## Shield

Only one shield was identified in grave 36 (SF 903), but no organic materials from the shield board were identified.

## Knives

Knives in a variety of shapes and sizes have been found in the six graves at Cumwhitton. Some of the materials associated with them include leather sheaths, and organic handles, some embellished with silver wire. The knife from grave 85 has a handle made from ash with decorative bindings of silver wire, very like an example from grave 22a, Fyrkat, Denmark, where the handle is made from *Prunus* sp. (Bullace) and decorated with silver wire (Roesdahl 1977, 119). The other knife with an inlaid handle was found in grave 25 made from horn with small filigree pieces of wire arranged in a pattern.

## Shears

There are two, possibly three pairs of shears located in the female graves 27 and 85. In grave 27 the shears appear to have been placed at the side of the grave in a leather bag along with an antler comb and an iron sickle. In grave 85 the shears were placed on top of an antler comb inside the 'needlework box'.

## Needlework box

It has been possible to produce a detailed reconstruction of the box from grave 85, and the results show similarities with other Scandinavian boxes, but none are identical *see* table 8. The size and type of wood used for this box compares closely with a similar box found at Scar, Orkney (Smith 1999); but the decorated lockplate is very like one found on the casket in Grave 4, Fyrkat, Denmark (Roesdahl 1977). The shape of the box and the joints used in its construction are like the examples from Scar and Mästermyr, Sweden (Arwidsson and Berg 1999).

Both the Cumwhitton and Scar boxes are made from maple which sets them apart from the Scandinavian examples which are recorded as being made from oak. Maple has been used for boxes placed in Anglo-Saxon graves, so the choice of this wood might be an English tradition and it would have a different appearance to one made from oak. The availability of maple may also account for its choice in these examples as *Acer campestre*, or field maple, is native to mainland Britain and SE Ireland but not Scandinavia; whereas *Acer platinoides*, Norway maple is not native to the British Isles (Hather 2000 128). It is very difficult to distinguish between the two species anatomically, but the type of ray identified in the Cumwhitton sample are more indicative of *Acer campestre* than *platinoides*, which might suggest that this box could have been made locally.

Table 8: Construction details of Viking caskets

Site	Width	Height	Depth	Thickness of sides	Other details
Cumwhitton, Cumbria	380mm (top), c.460mm (base)	230mm + feet	c.110 – 160mm	Tc.12mm with 4mm rebate	Trapezoid shape with curved lid, wood: maple.
Scar, Sanday, Orkney (Smith 1999)	250-300mm	uncertain	100-150mm	c.12mm with rebate	Badly preserved. Wood: maple.
Mästermyr, Sweden (Arwidsson and Berg 1999)	860mm (top), 885mm (base)	200mm + 20mm feet	260mm	18 – 25mm	Trapezoid shape. Base joined to ends with mortise and tenon joints. The ends extend below the front and back by 20mm, which act as feet. Wood: oak.
Birka, Denmark Grave 639 (Arbman 1940 and Arbman 1943)	450mm	~ 160mm	~ 115m	side ~ 12mm, lid ~ 14mm	Plain rectangular box with flat lid and base.
Birka, Denmark Grave 849					Trapezoid shape with curved lid
Fyrkat, Denmark Grave 4 (Roesdahl 1977)	240mm				Plain rectangular box. Woods: oak, with repairs in poplar. Contains shears in willow/poplar case.
Oseberg, Norway 149 (Almgren <i>et al</i> 1995)	1080mm (top), 1130mm (base)	380mm inc. feet	290mm (Top), 320mm (base)		Trapezoid shape, wood: oak
Oseberg, Norway 156	1040mm	410mm	280mm (top), 365mm (base)		Probably trapezoid shape, wood: oak.
Oseberg, Norway 178	620mm (top), 665mm (base)	310mm	210mm (top), 240mm (base)		Trapezoid shape, wood: oak.

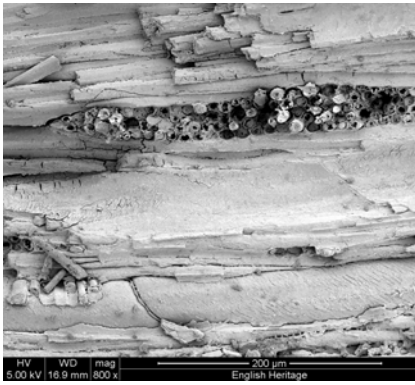


Figure 116: SF 33 SEM B898a mineral preserved wood from needlework box seen in TLS with ray vessel elements.

## Combs

There are no intact examples from this cemetery, all that remains are the iron rivets in grave 85, SF 33 (Fig. 117) and fragments of antler preserved on other iron objects such as shears in graves 27 (SF 785) and 85 (SF 33). In the case of the comb from grave 27 enough is preserved of the antler to give an indication of the shape and decoration of the original.

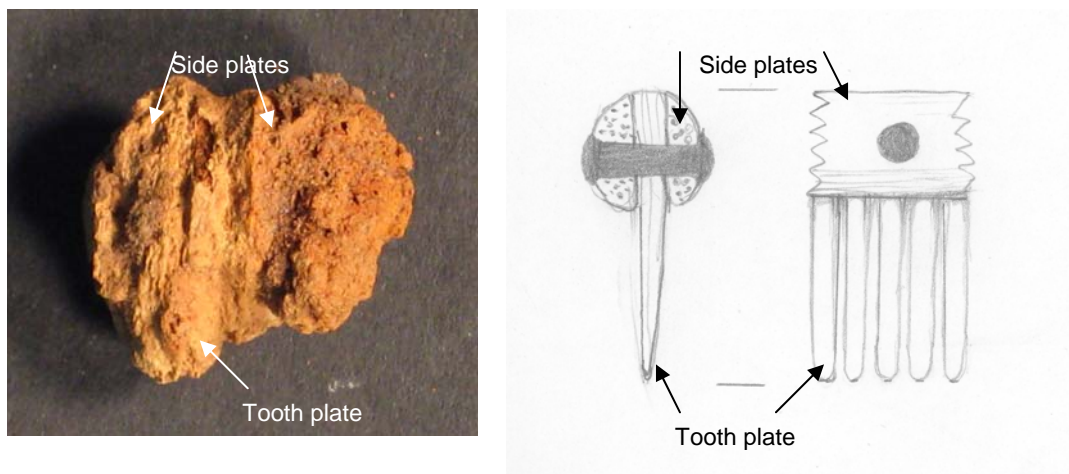


Figure 117: SF 33 Comb rivet with mineral preserved sections of antler and illustration of the comb sections they represent.

## Drinking horns

Two copper alloy mounts for drinking horns have been identified in graves 25 (SF 889) and 27 (SF784).



## Buckles

Most of the copper alloy buckles appear to have been made from non-specific copper/tin alloys or bronzes that are too de-cuprified to classify properly. Some also have tinned surfaces which has protected them a little from the acidic soil conditions. Many have decorated plates often with the remains of the leather belt between two thin sheets of metal.

Buckle SF 793 in grave 27 has preserved a large area of textile and pelt which may have come from a sealskin garment.

## SUMMARY

Despite the poor condition of the assemblage, it was possible through investigative conservation to reveal and record information about the finds relating to materials and construction details including the reconstruction of objects from fragmentary evidence.

The burial conditions were not conducive to the preservation of organic material. However, evidence of horn, antler, wood, leather, textile and hair was found as mineral preserved organic material on iron and copper alloy objects. A wooden box was reconstructed from wood preserved on iron brackets, hinges, strapping and a lockplate located in the largest soil block. The box contained various tools for textile working and is referred to as a needlework box.

It has been possible to identify some of the wood to species level: in the case of the needlework box, it was made from maple, probably *Acer campestre* (field maple) native to the British Isles rather than *Acer platanoides* (Norway maple) which was common in Scandinavia. Although the box is identical in construction with similar iron-bound chests found in Scandinavian cemeteries, the choice of wood could indicate that this one was made locally, rather than brought from abroad.

Other wood species identified include *Salix sp.* (willow) or *Populus sp.* (poplar), *Buxus sp.* (box), ash (*Fraxinus sp.*) and oak (*Quercus sp.*) all of which were native to the British Isles and Northern Europe during this period. Textile evidence included a potential sealskin cape lined with textile (a vegetable fibre: linen). The corrosion products also preserved evidence of mites (*Acarina*), false scorpion (*Pseudoscorpione*) and possible louse which provided an insight into the decay patterns within one grave.

Investigative conservation of the metalwork revealed evidence of tinning, non-ferrous inlays, pattern welding and solders. Some of this information is only evident in the X-radiographs (pattern welding) whilst for other objects it was possible to confirm through XRF analysis. For the great majority of the objects, the investigative conservation process involved the recovery of trace evidence through the use of imaging techniques, the careful

removal of corrosion products to clarify detail and the targeted use of analytical techniques. At the time of writing the finds and archive are being analysed and prepared for final publication by Oxford Archaeology North.

## REFERENCES

- Almgren, B, Blindheim, C, de Bouard, Y, Capelle, T, Christensen, AE, Eldjam, K, Perkins, RM, Ramskou, T, Sawyer, P and Henning, I 1995 *The Viking: The Settlers, Ships, Swords, and Sagas of the Nordic Age*. New York: Barnes & Noble
- Arbman, H 1940 *Birka I: Die Graber (Tafeln)*. Almqvist & Wiksells
- Arbman, H 1943 *Birka I: Die Graber (Text)*. Almqvist & Wiksells
- Arwidsson, G and Berg, G 1999 *The Masternyr Find*. Larson Publishing Company
- Arwidsson, G. and Thorberg, T. 1989 '23. Kästen und schachteln', in Arwidsson, G (ed) *Systematische Analysen der Gräberfunde, Birka II: 3*, 113-121
- Brennand, M 2006 Finding the Viking dead, *Current Archaeology*. 204, 623-629
- Cameron, E 2000 *Sheaths and Scabbards in England AD 400-1100*, Oxford: British Archaeological Report series 301
- Giangrande, C 1987 "Identification of Bronze Corrosion Products by Infrared Absorption Spectroscopy", in J Black (ed), *Recent Advances in the Conservation and Analysis of Artifacts*. London: Summer School Press, 135-148
- Hather, JG 2000 *The Identification of Northern European Woods*. London: Archetype Publications.
- Hunter, F 2008 'Jet and related materials in Viking Scotland.' *Medieval Archaeology* 52, 103-117
- IRUG 2000 *Infrared and Raman User Group*, [www.irug.org](http://www.irug.org) (accessed: March, 2006)
- MacGregor, A 1985 *Bone, Antler, Ivory and Horn: Technology of Skeletal Materials Since the Roman Period*. London: Croom Helm
- Oxford Archaeology North 2008 *Townfoot Farm, Cumwhitton, Cumbria. Post-Excavation Assessment Report*. Unpublished report

Penton, S 2008 *Cumwhitton, Cumbria: analytical investigation of jet-like objects from a Viking cemetery* RDRS report 18-2008. Portsmouth: English Heritage.

Roesdahl, E 1977 'Brackets and other fittings for boxes' in *Fyrkat. A Viking fortress in Jylland. II. The finds and the cemetery*, Nordiske Fortidsminder. Ser B in quarto, 4, Copenhagen, 95-99, 114-124.

Scott, DA 2002 *Copper and Bronze in Art: Corrosion, Colorants and Conservation*. Los Angeles: The Getty Conservation Institute, 39

Selwyn, L 2004 *Metals and Corrosion: a Handbook for the Conservation Professional*, Canada: Minister of Public Works and Government Services

Smith, A 1999 'The Box fittings' in Owen, O and Dalland, M, *Scar: A Viking Boat Burial on Sanday, Orkney*. East Linton: Tuckwell Press, 96-100

Watson, J and Edwards, G 1992 *The identification of organic material preserved on ironwork from Burton Fleming, North Yorkshire*. AML Report Series, 67/92. London: English Heritage.

Welander, RDE, Batey, C and Cowie TG, 1987 'A Viking burial from Kneep, Uig, Isle of Lewis', *Proceedings of Society of Antiquaries for Scotland*, 117, 149-174

## APPENDIX A: ANALYSIS OF TORTOISE BROOCHES

### Introduction

This report covers the analytical work undertaken to establish what metals the SF I tortoise brooches were made from, as well as identifying the brightly coloured corrosion products to see if they were the result of unusual burial conditions.

The objectives of the research include the following:

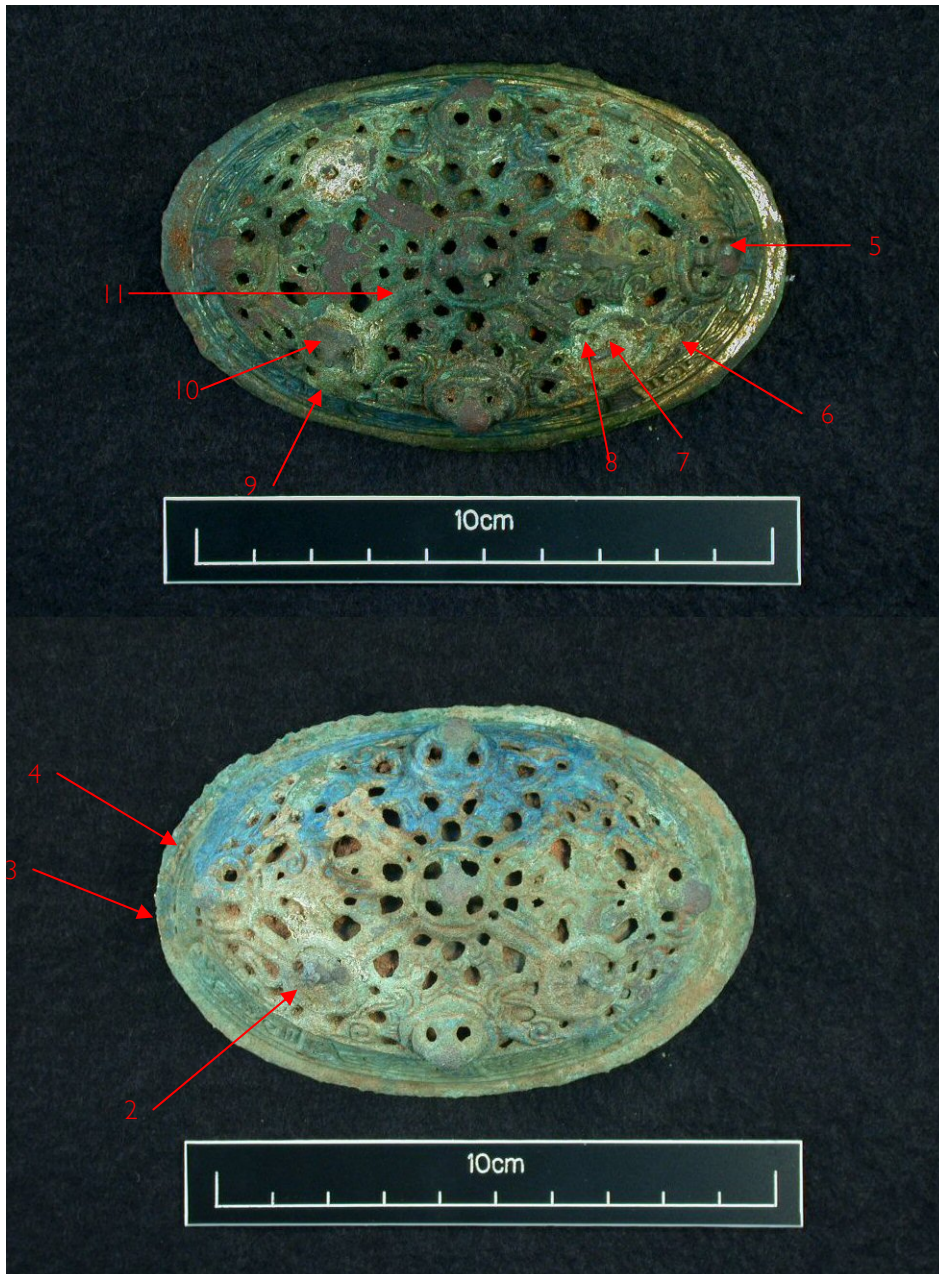
1. To find out information about the material type of the brooches, the decorative technology, and manufacture evidences.
2. To identify the different copper alloy corrosion products present on the brooches, and to identify the coating material on one of the brooches.

### Methodology

Energy dispersive x-ray fluorescence (XRF-ED) was used to perform a quick and non-destructive analysis. It is however worth noting that only a very thin layer of the surface of the samples can be detected, one therefore needs to be careful with the interpretation of the data. Ten spots on the two brooches were selected as analysing locations, and they were listed in Table 1, as well as marked in Figure 118.

*Table 9: Locations of the XRF analysis on the brooches.*

Location	Description
2	Solder material, near the rivet
3	Brooch body covered with blue corrosion
4	White metal at the 8 corners of the border of brooch A
5	White metal at the 8 corners of the border of brooch B
6	Gilded surface
7	White corrosion product near a rivet
8	One of the rivets
9	White metal at the 8 corners of the border of brooch B
10	Solder material, near the rivet
11	Brooch body covered with green corrosion product



*Figure 118: Locations of the XRF analysis on the brooches. Top: brooch B; bottom: brooch A.*

X-ray diffraction (XRD) powder analysis was used to identify the corrosion products, and Fourier Transform Infrared Spectroscopy (FTIR) was also used to confirm the results from XRD analysis. There are at least two types of corrosion products visually distinguishable on the brooches, one bright blue and the other green (Fig. 118). Powder samples were taken using a scalpel from the reverse side of the brooch A, and after XRD analysis, the powder samples were mixed with potassium bromide (KBr) and pressed to be pellets for FTIR analysis.

FTIR was also used to identify the coating material on the brooch B. A small lump of the white material, trapped in a decorative hole of the brooch, was sampled and prepared for analysis.

## Results and conclusions

### XRF analysis of the ten locations on the brooches

The spectrums of XRF analysis on the ten locations are presented in Figures 119 to 128. The spectrums suggest that:

1. The metal of the brooches is copper and zinc alloy, that is brass;
2. The four missing bosses of each brooch were riveted to the brooch, and the solder material is lead – tin alloy;
3. The rivet is possibly copper, tin and lead alloy, but this is not conclusive because the analysing location is very close to the solder material which is rich in tin and lead;
4. The brooches were gilded, but no mercury was detected;
5. The white metal, which is more clearly visible at the eight corners of the border of each brooch, seems to be lead – tin alloy, but uncertain if this is a type of plating or not.
6. White lead corrosion products were detected around the rivets, and it is probably from the solder material, or fillers.

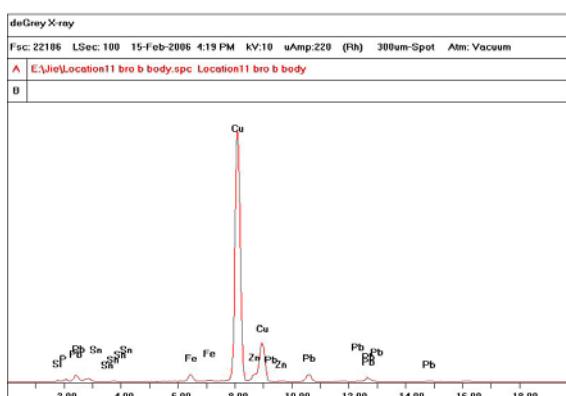


Figure 119: SF I Brooch B Location 11. Brooch body covered with green corrosion product

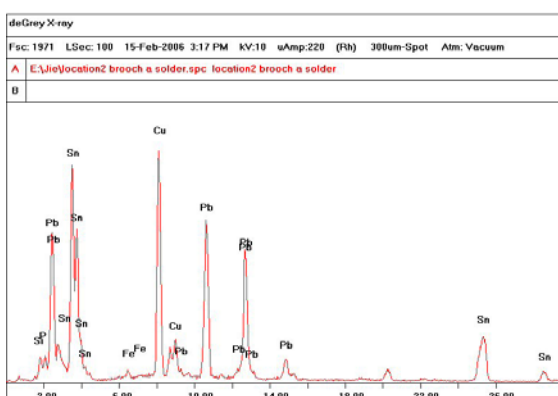


Figure 120: SF I Brooch A Location 2. Solder material, near the rivet



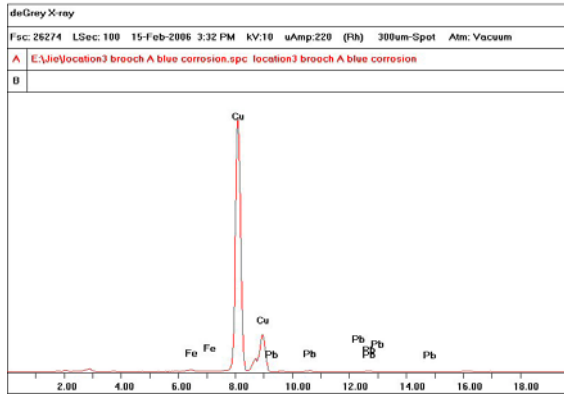


Figure 121: Brooch A Location 3. Brooch body covered with blue corrosion

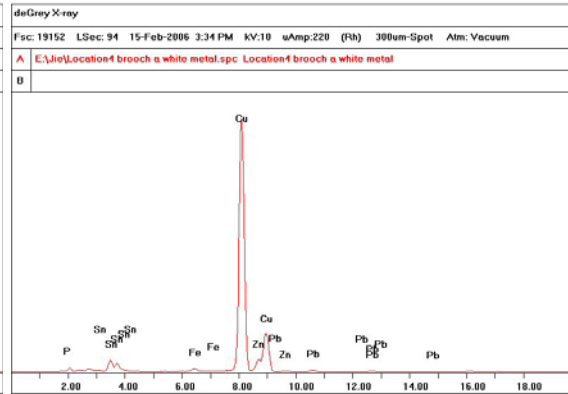


Figure 122: Brooch A Location 4. White metal at the 8 corners of the border of brooch A

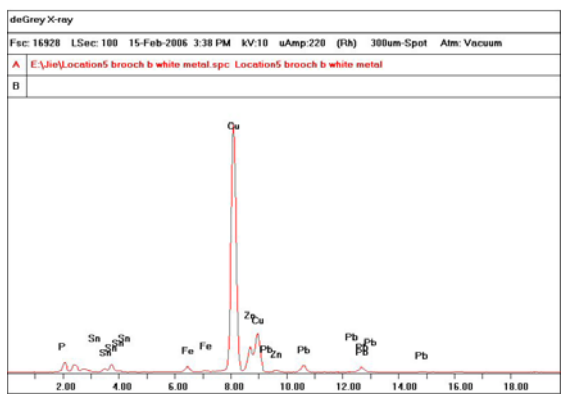


Figure 123: Brooch B Location 5. White metal at the 8 corners of the border of brooch B

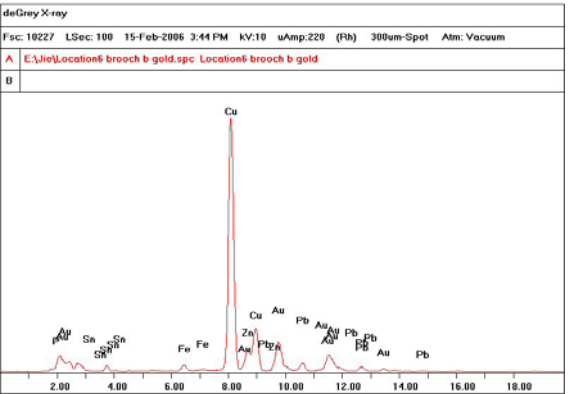


Figure 124: Brooch B Location 6. Gilded surface

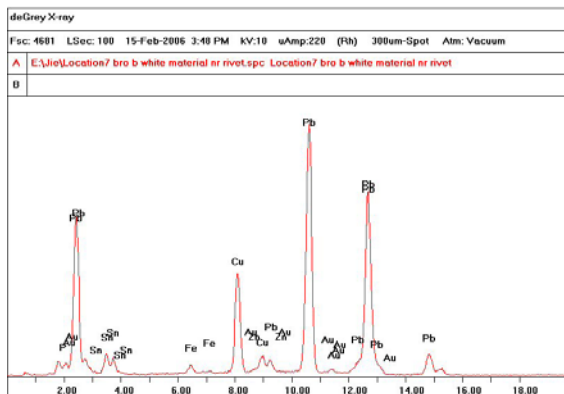


Figure 125: Brooch B Location 7. White corrosion product near a rivet

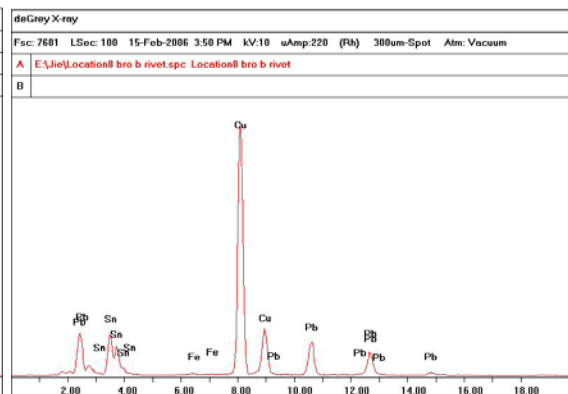


Figure 126: Brooch B Location 8. Rivet.

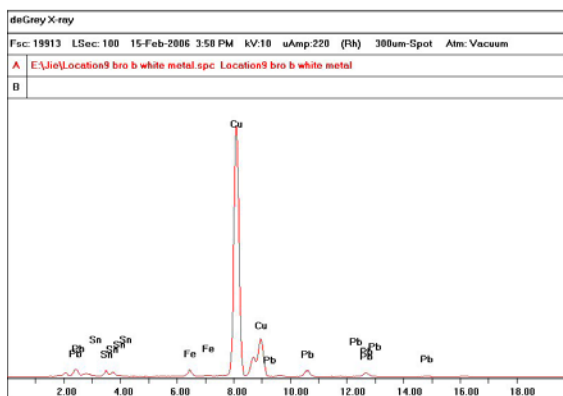


Figure 127: Brooch B Location 9. White metal at the 8 corners of the border of brooch B.

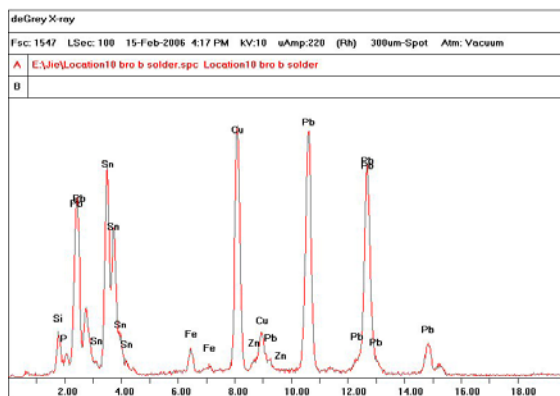


Figure 128: Brooch B Location 10. Solder material, near the rivet

### XRD and FTIR analysis of the corrosion products

The XRD spectrums of the blue corrosion samples were identified using Philip PC-Identity Database, and Figure 129 shows the best matching reference as azurite. Probably because the corrosion product in the sample was mostly amorphous, the analysis did not obtain a spectrum that is convincing enough, but gave an idea of what would be expected in the FTIR analysis.

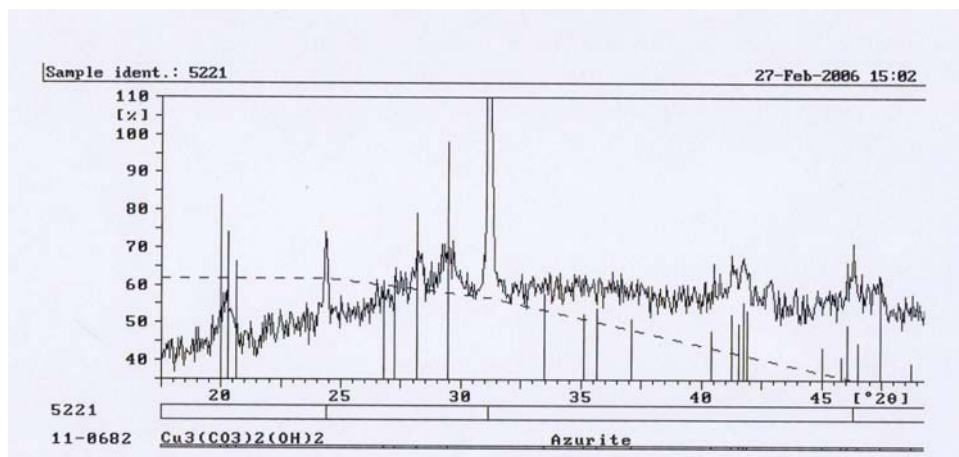


Figure 129: The XRD spectrum of blue corrosion product.

The analysis on the green corrosion unfortunately did not give an informative result. The spectrum contained no peaks other than quartz.

Figure 130 shows the infrared spectrums of the corrosion products with the main peaks labelled.

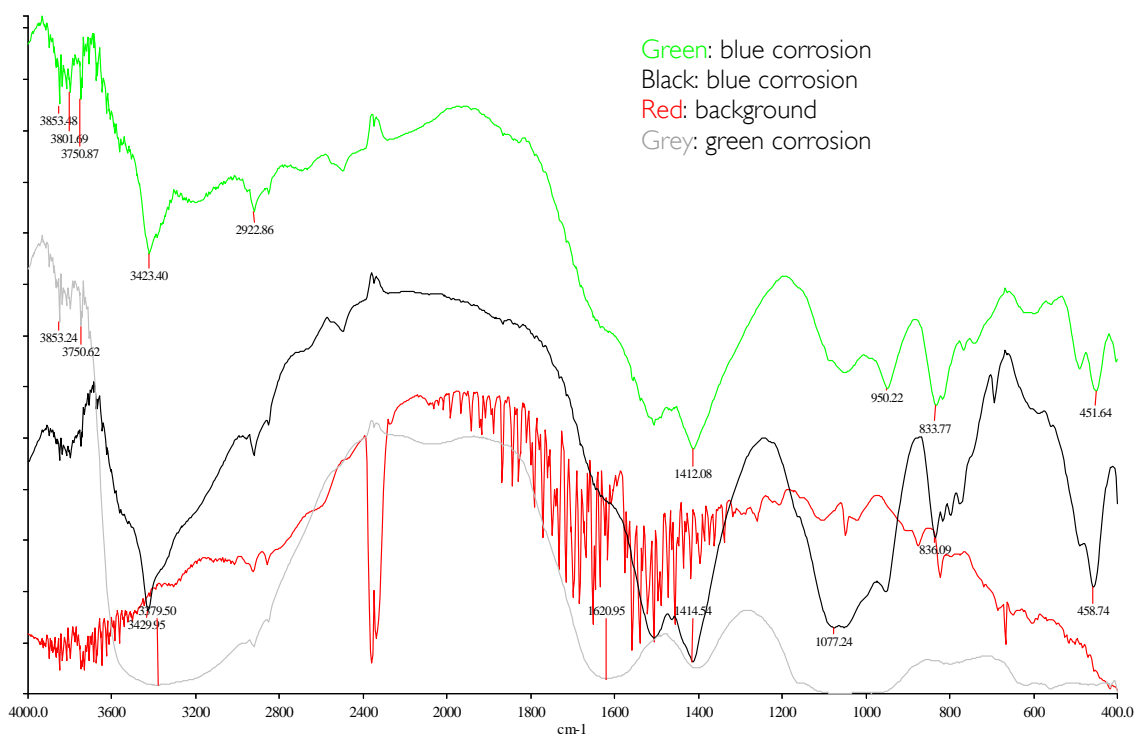


Figure 130: The FTIR spectrums of the corrosion products.

The absorptions at different frequencies in the infrared spectrums correspond to different chemical compounds in the samples. When interpreting the data, there are three features of the peaks that need to be examined: the frequencies, the shape of the peaks, and the strength of the absorptions.

The spectrums of the blue corrosion products, which are indicated as green and black lines in Figure 130, were compared with the spectrum of azurite obtained from online Infrared and Raman User Group (IRUG). The frequencies of the bands match with those of corresponding bands of azurite, but the shape and strength of bands are not perfectly matching, probably due to the impurity of the unknown sample and its preparation. Cathy Giangrande has performed experiments on the identification of copper alloy corrosion products using FTIR, and developed a method of interpreting the peaks of the spectrums (Giangrande 1987). The spectrums of the blue corrosion again match with that of azurite in her paper (Table 10).

Table 10: Peaks comparison between the blue corrosion and azurite.

Peaks of Azurite	Peaks of the blue corrosion samples	
	Green line in Fig.3	Black line in Fig.3
3430 strong/sharp	3423 strong/sharp	3430 strong/sharp
3370 shoulder	3370 shoulder	3370 shoulder
1495 strong/ broad	1500 weak/broad	1495 weak/broad
1465 weak	1465 very weak	1465 very weak
1415 very strong	1412 very strong	1415 very strong
1090 weak	1080 weak	1077 weak
950 strong/sharp	950 strong/sharp	950 weak
835 strong/sharp	834 strong	836 strong/sharp
820 medium/strong, shoulder	820 weak/shoulder	820 weak/sharp
770	Not obvious	Not obvious
745		
615		
495		
455 strong/sharp	452 strong/sharp	459 strong/sharp
405	Not present	

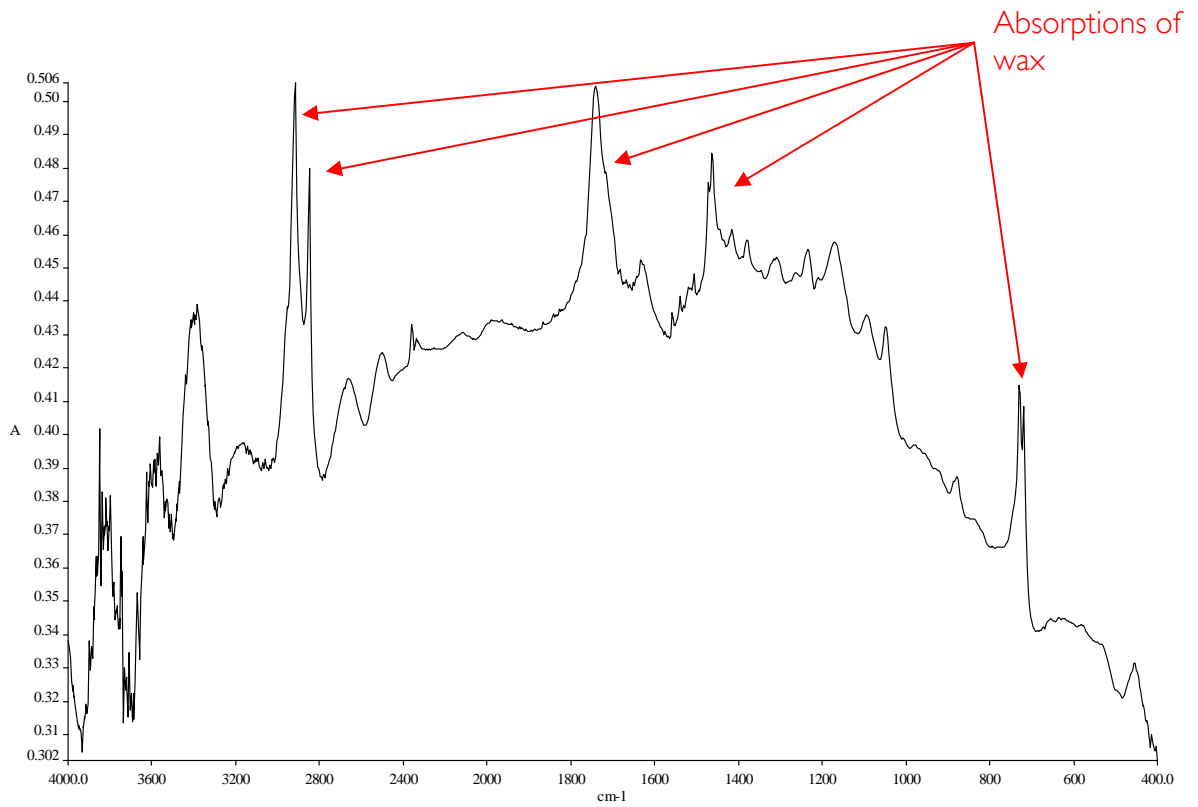
The spectrum of the green corrosion product does not contain informative peaks.

By combining the results from both XRD and FTIR analysis, it is possible to conclude that the blue corrosion product probably contains mainly azurite (copper carbonate hydroxide). As the brooches were recovered from a grave in association with organic materials, the presence of carbonates is expected, and the mechanism of azurite formation in buried environments is discussed in Selwyn (2004).

No conclusion about the green corrosion product could be made based on the analytical results. The visual structure of the corrosion products on the brooches however suggests that the green corrosion product could be of similar material but much less crystallized.

### Identification of the coating material with FTIR analysis

Figure 131 shows the infrared spectrum of the coating material sample. The group of bands marked with red arrows in Figure 131 shows the absorption pattern of wax. It is difficult to identify it as a particular type of wax, because most of the waxes have similar infrared absorption patterns according to the database in IRUG



*Figure 131: Infrared spectrum of the coating material sample from brooch B*



## **ENGLISH HERITAGE RESEARCH AND THE HISTORIC ENVIRONMENT**

*English Heritage undertakes and commissions research into the historic environment, and the issues that affect its condition and survival, in order to provide the understanding necessary for informed policy and decision making, for sustainable management, and to promote the widest access, appreciation and enjoyment of our heritage.*

*This research provides English Heritage with capacity in the fields of buildings history, archaeology, and landscape history. It brings together seven teams with complementary investigative and analytical skills to provide integrated research expertise across the range of the historic environment. These are:*

- \* Aerial Survey and Investigation*
- \* Archaeological Projects (excavation)*
- \* Archaeological Science*
- \* Archaeological Survey and Investigation (landscape analysis)*
- \* Architectural Investigation*
- \* Imaging, Graphics and Survey (including measured and metric survey, and photography)*
- \* Survey of London*

*These teams undertake a wide range of investigative and analytical projects, and provide quality assurance and management support for externally-commissioned research. We aim for innovative work of the highest quality which will set agendas and standards for the historic environment sector. In support of this, and to build capacity and promote best practice in the sector, we also publish guidance and provide advice and training. We support outreach and education activities and build these in to our projects and programmes wherever possible.*

*We make the results of our work available through the Research Report Series, and through journal publications and monographs. Our publication Research News, which appears twice a year, aims to keep our partners within and outside English Heritage up-to-date with our projects and activities. A full list of Research Reports, with abstracts and information on how to obtain copies, may be found at [www.english-heritage.org.uk/publications/research-reports/](http://www.english-heritage.org.uk/publications/research-reports/)*

*For further information visit [www.english-heritage.org.uk](http://www.english-heritage.org.uk)*

