



Historic England

The Application of Building Information Modelling (BIM) within a Heritage Science Context

Carl Brookes

Discovery, Innovation and Science in the Historic Environment

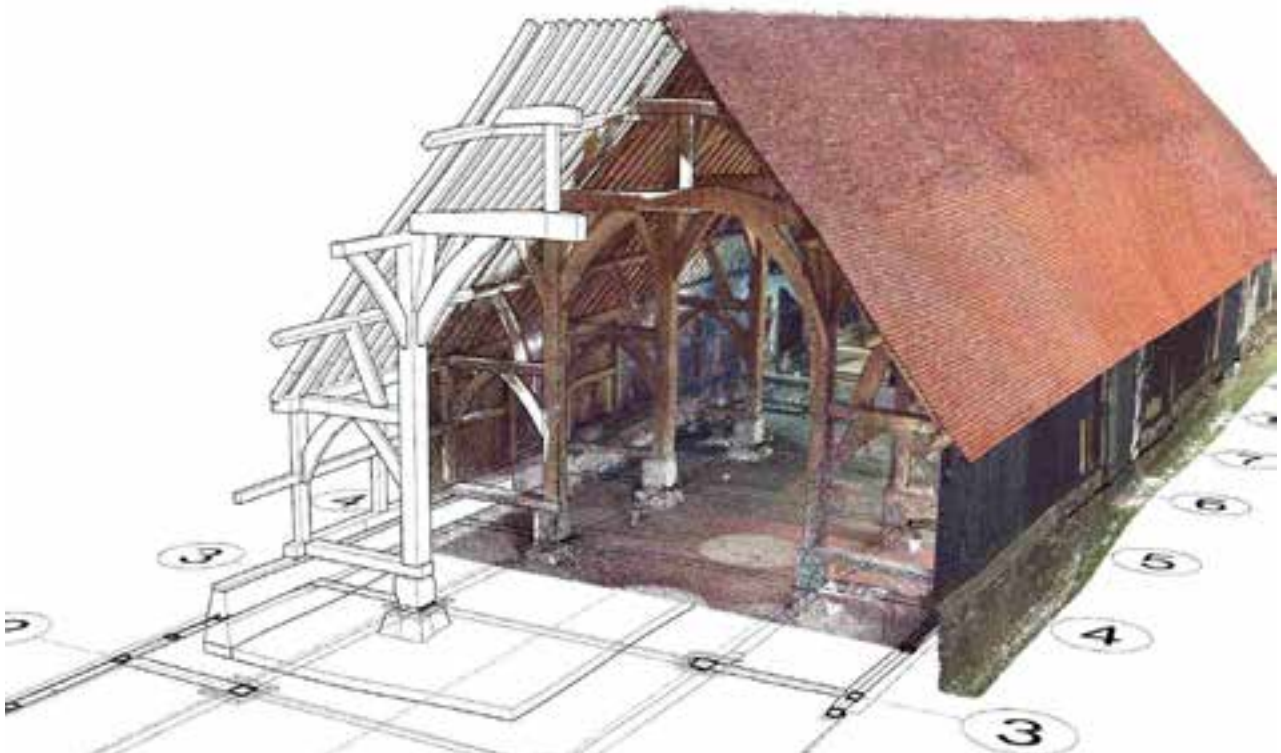

Intended for
Historic England

Document type
Report

Date
January, 2017

THE APPLICATION OF BUILDING INFORMATION MODELLING (BIM) WITHIN A HERITAGE SCIENCE CONTEXT

PROJECT NUMBER 7351

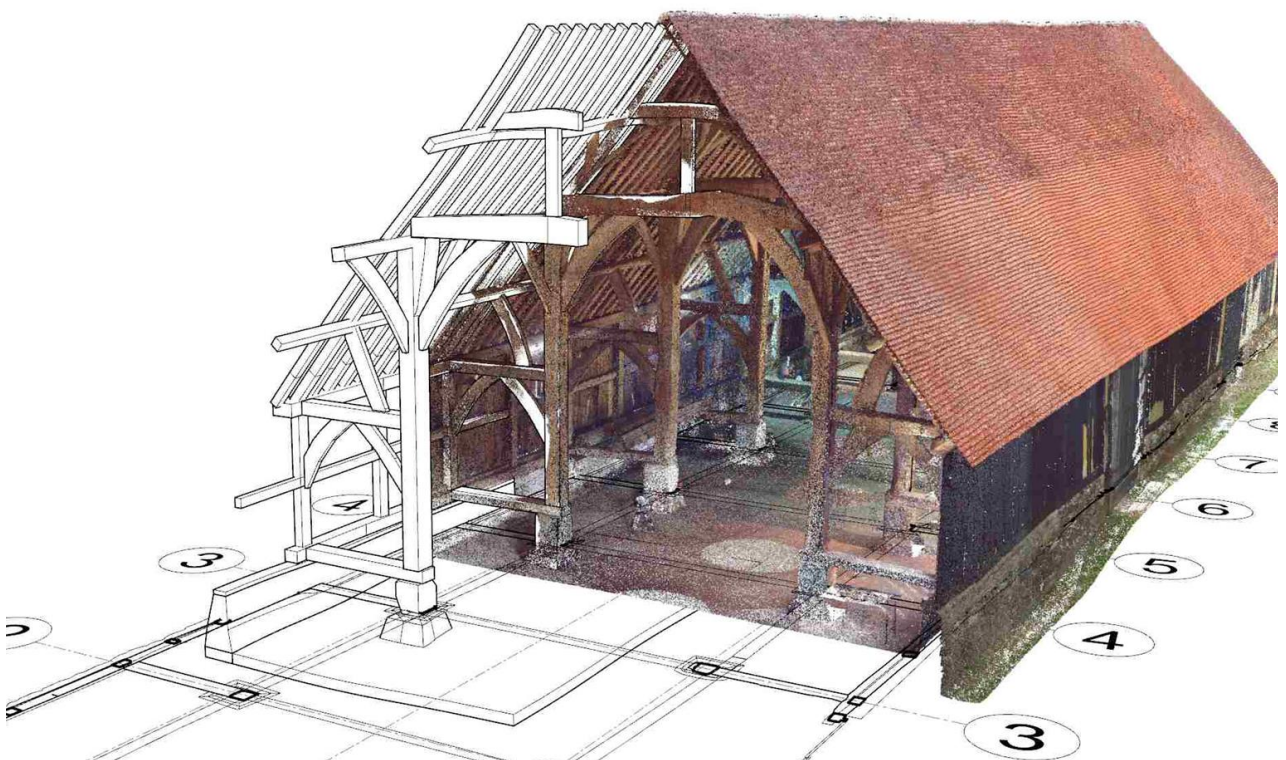

**THE APPLICATION OF BUILDING INFORMATION
MODELLING (BIM) WITHIN A HERITAGE SCIENCE
CONTEXT
PROJECT NUMBER 7351**

Revision **Final**
Date **27/01/2017**
Made by **Carl Brookes**

Checked by **Tiziana Meciani, Daniel Niziolek**

Approved by **Carl Brookes**

Description **Report**

Ref 1620001834/R01

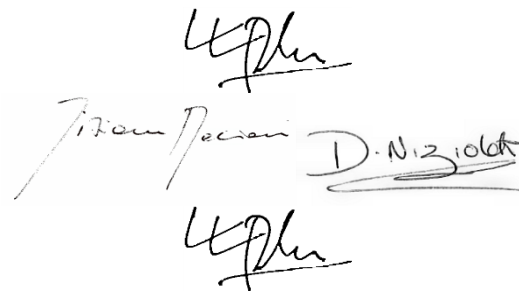

Document Control Grid	
Project Name and HE reference number	The application of building information modelling (BIM) within a heritage science context Project No: 7351
Author(s) and contact details	Carl Brookes, carl.brookes@ramboll.co.uk Tel. 07918 054817
Origination date	27 January 2017
Reviser(s)	
Version	
Date of last revision	
Summary of changes	

CONTENTS

1.	SUMMARY	1
2.	INTRODUCTION	2
2.1	General	2
2.2	Brief	2
2.3	Abbreviations	3
2.4	Sources of information	4
2.5	Software	4
2.6	Models produced	5
3.	BACKGROUND	6
3.1	CAD	6
3.2	BIM	7
4.	NEW BUILD	8
4.1	Construction	8
4.1.1	Industry Foundation Class	10
4.2	Asset Management	10
5.	EXISTING ASSETS	11
6.	HERITAGE ASSETS	12
6.1	Conservation emphasis	12
6.2	English Heritage asset management system	14
7.	LEVEL OF MODEL DEFINITION	15
7.1	General	15
7.2	New-build	15
7.2.1	Level of Detail	16
7.2.2	Level of Information	18
7.3	Heritage Assets	19
7.3.1	Level of Detail	19
7.3.2	Level of Information	20
7.3.3	Heritage Significance	20
8.	HERITAGE - LEVELS OF DETAIL	20
8.1	General	20
8.2	Classification of surveys	21
8.3	Level of detail	22
9.	HERITAGE – LEVEL OF INFORMATION	28
10.	BIM DATASETS	30
10.1	Positioning	30
11.	HARMONDSWORTH BARN	31
11.1	General	31
11.2	Modelling and LoD	32
11.3	360 degree imagery	38
11.4	Monitoring and comparisons	43
11.5	Handheld scanning dataset	46
12.	THE IRON BRIDGE	52
12.1	General	52

12.2	Modelling and LoD	52
12.3	Hybrid modelling	57
12.4	360 degree imagery	59
13.	CONCLUSIONS	60
13.1	General	60
13.2	Recommendations	61
14.	REFERENCES	62

TABLES

Table 2-1 Datasets provided for Harmondsworth Barn and The Iron Bridge	4
Table 2-2 Modelling software used to develop datasets.....	4
Table 2-3 Models developed for Harmondsworth Barn	5
Table 2-4 Models developed for The Iron Bridge	5
Table 7-1 Level of model definition, new-build simple illustrations.....	15
Table 7-2 AEC (UK) BIM Protocol suggested Levels of Detail (LoD).....	16
Table 7-3 NBS suggested Level of Detail.....	17
Table 7-4 NBS suggested Level of Information	18
Table 7-5 Historic England Metric Survey suggested Levels of Detail (LoD)....	19
Table 7-6 English Heritage classification for buildings	20
Table 8-1 Classification of survey techniques and processes	21
Table 8-2 Level of Detail - Harmondsworth Barn example	23
Table 8-3 Level of Detail, 2D information - Harmondsworth Barn example	24
Table 8-4 Level of Detail, Hybrid environments - Harmondsworth Barn example	25
Table 8-5 Proposed level of Detail – The Iron Bridge example.....	26
Table 8-6 Level of Detail, 2D information – The Iron Bridge example.....	27
Table 8-7 Level of Detail, Hybrid environments – The Iron Bridge example ...	27
Table 11-1 Example Model Data	34
Table 11-2 Example Element Data	35

FIGURES

Figure 3-1 BIM maturity levels (reproduced from PAS 1192-2:2013).....	8
Figure 4-1 Information delivery cycle (reproduced from PAS 1192-2:2013)....	9
Figure 4-2 CIC BIM Cyclic diagram	10
Figure 4-3 Asset management delivery cycle (reproduced from PAS 1192-3).11	
Figure 5-1 Relationship of AIM with asset management systems	12
Figure 6-1 Emerging HBIM framework cyclic diagram	13
Figure 6-2 Proposed heritage topics mapped to CIC stages	14
Figure 9-1 BIM LoI conservation influencing factors.....	29
Figure 10-1 Screen shots from GIS GUI showing site positions	31
Figure 11-1 GIS for Harmondsworth Barn site	32
Figure 11-2 Images of the Harmondsworth Barn 3D model	33
Figure 11-3 Sample LoD 2 BIM model.....	34
Figure 11-4 Edgewise model with and without the point cloud	36
Figure 11-5 Agisoft and ReCap models	37
Figure 11-6 Model produced by ReCap and viewed by AutoDesk ReMake	38
Figure 11-7 360 degree image navigation pages at Harmondsworth Barn	39
Figure 11-8 Example 360 degree photos of Harmondsworth Barn	40
Figure 11-9 Screenshots of the ReCap 360 Real View data	41
Figure 11-10 Images of the 360 imagery of Harmondsworth Barn Hybrid Models.....	42
Figure 11-11 Baseline compared to Pre conservation (2013)	43
Figure 11-12 Large differences between 2013 and baseline	44
Figure 11-13 Baseline to external photogrammetry	45
Figure 11-14 REVO Trajectories, top: 20 minute survey, bottom: 2 minute survey	46
Figure 11-15 20 minute REVO survey to baseline.....	47
Figure 11-16 2 minute REVO survey to baseline	48
Figure 11-17 Section through baseline, 20 and 2 minute surveys.....	49
Figure 11-18 3D view of 20 minute REVO (left) and 2 minute REVO (right) ...	49
Figure 11-19 Views of the 3D model created from the 20 minute REVO survey	50
Figure 11-20 REVO point cloud shading	51
Figure 11-21 REVO data with RGB and grayscale colour from post conservation data	51
Figure 12-1 GIS for the Iron Bridge site.....	52
Figure 12-2 Iron Bridge 3D model displayed by Autodesk 360	53
Figure 12-3 Sections cut through the Iron Bridge model in Autodesk 360.....	53
Figure 12-4 Structured model data and 3D markers	54
Figure 12-5 Markers linked to a report.....	55
Figure 12-6 Markers linked to a Hub Page	56
Figure 12-7 IFC file imported into Revit 2016	57
Figure 12-8 3D Marker object in Revit	58
Figure 12-9 Repair detail modelled in Revit to fit the point cloud.....	58
Figure 12-10 Examples of Iron Bride 360 degree imagery	59

APPENDICES

Appendix 1 LOD VISUAL EXAMPLES

1. SUMMARY

Aware of the Significance of BIM in construction and facilities management, Historic England have commissioned Ramboll to identify relevant processes and datasets that would potentially allow their heritage sites to be managed using BIM procedures. Ramboll Engineering Simulation and Heritage Teams have examined the more established New-Build BIM processes, including reviewing existing standards, to map out those that have particular relevance to conservation activities. References to standards have been largely based on UK guidelines.

To provide examples, Historic England have selected two important Grade I listed sites to focus the work and provided the relevant datasets; the oak framed Harmondsworth Barn built in 1426, and The Iron Bridge over the river Severn built in 1779. Unlike New-Build there is no design process that directly leads to a model and information environment. Consequently, measurement and data capture technologies are particularly relevant to be able to consider using a BIM environment.

Using the existing datasets for these two sites the headline objective has been to determine how a BIM environment would benefit the heritage science process. This has involved building examples to illustrate established BIM metrics such as level of modelling definition, level of detail (graphical information) and level of information (non-graphical information), albeit in a heritage context, but also measurement classification to achieve the required model fidelity. In so doing topics such as BIM Levels, GIS, laser scanning, UAVs, digital photogrammetry, LAM®, monitoring and interaction with datasets in various formats, have been explored. Also briefly discussed is the English Heritage estate assessment management system and how this could be an important interface with BIM.

To assist in determining the most appropriate adoption of BIM for individual heritage projects, tables have been produced that firstly classify different survey technologies for different scales of project, and secondly set out different levels of detail for different heritage and conservation activities. An important method of working involving a hybrid environment where point clouds and BIM objects are used together is also introduced into these tables. Hybrid environments have many modelling and cost benefits although they are not yet adequately supported by main stream modelling software products. Illustrations of models at each level of detail have also been included in these tables to help show the expected detail and potential usages. The scope of work for this project was also slightly extended to include a hand held laser survey of Harmondsworth Barn including comparisons with traditional laser surveys as this emerging technology is likely to be a significant factor in developing BIM datasets in the future.

In parallel to this report a web domain has also been purchased to provide working examples based on the two sites. These examples are entirely Cloud based so that only a web browser is required to run these examples; no software has to be installed. The software that has been used for this work, to develop models, is listed in this report and the corresponding datasets have been issued electronically.

The overall finding of this project is that BIM within a heritage context is likely to be more complex than for New-Build as it nearly always involves measurement to establish any kind of model, the coordination of different types of legacy information and the organisation of often unique objects. Many of the advantages that are immediately apparent with new-build, for instance that an asset information model is handed over after construction, do not exist for BIM for heritage. However, this project has demonstrated how simple environments can be used to organise information and geometry and that BIM processes do have the potential to make heritage work more efficient. More detailed conclusions are presented on specific aspects of modelling and implementation of BIM, but another important observation is that a Cloud based implementation is likely to be most effective for heritage work. This will reduce the investment required for modelling software, computer hardware and developing specialist modelling skills

which is of particular benefit to small to medium asset owners. It should also make accessing a common data environment easier for different organisations.

Recommendations for further work have been made including a study to see how the English Heritage estate asset management system could be used to help facilitate BIM in a standardised way, perhaps even fully integrating BIM with this system. Much of the information required to link to the model (non-graphical data) may already exist in an organised way which may greatly accelerate BIM development. It is also recommended that more work is required to set out the different levels of information required for different conservation activities to echo the more easily defined levels of graphical detail that it has been possible to suggest.

2. INTRODUCTION

2.1 General

This research study titled "The application of Building Information Modelling (BIM) within a heritage science context", project number 7251, and was awarded to Ramboll by Historic England by successfully winning a tender competition.

The Historic England Project Assurance Officer was Paul Bryan.

This work has been carried out in accordance with Historic England's standard Heritage Protection Commissions Funding Agreement, dated May 2016.

An extension to this work was made by HE to survey Harmondsworth Barn using a hand held laser scanner. This was carried out on 7 June 2016 by Ramboll and provided a series of additional point cloud datasets.

2.2 Brief

The principal activities that were proposed for this research project fall mainly under three headings as follows.

Research

- 1 Research and analyse existing guidelines on BIM relating to heritage application. Necessary to this activity has been the review of new-build BIM guidelines which, whilst still being developed, are far more mature than those suggested for heritage assets.
- 2 Research the heritage science and heritage conservation processes applicable to historic structures through consultation with relevant stakeholders. This has mostly involved input from Ramboll heritage specialists, members of the BIM4Heritage special interest group, and discussions with participants during the BIM4Heritage Ramboll/COTAC conference held on 9 December 2016.

Collate existing datasets

- 3 Collate existing survey and BIM-ready datasets for Harmondsworth Barn and The Iron Bridge.
- 4 Determine scope of BIM generation including site visits to both projects. As part of the site visit to Harmondsworth Barn additional datasets were obtained by several handheld laser scanner surveys.

BIM production and verification

- 5 Undertake BIM production for both sites. Work here has been adapted given the level of non-graphical information available. Although an understanding of the software applications and primary asset database system English Heritage use has been gained it has not been possible to link existing heritage information with the datasets provided. Instead, various illustrations have been completed using partly developed BIM environments which set out different paths to reach an understanding of various BIM processes and levels which have useful applications for asset management within a heritage context.
- 6 Undertake field checking of derived BIM data to quantify degree of fit, level of completion and presence of voids.
- 7 Undertake testing of derived models against specific heritage science and heritage conservation processes.

2.3 Abbreviations

AIM	asset information model
BEP	BIM execution plan
BIM	Building information modelling
CAD	Computer aided design
CapEx	Capital expenditure
CDE	Common data environment
CIC	Construction Industry Council
CMP	Conservation Maintenance Programme
COTAC	Council on training in architectural conservation
EH	English Heritage
EIR	employer's information requirements
GIS	Geographic information system
GUI	Graphical user interface
HE	Historic England
HBIM	BIM for heritage assets
LAM	Laser aided modelling
LoD	Level of detail
LoI	Level of information
LoMD	Level of model definition
NBS	National Building Specification
OpEx	Operational expenditure
PAS	Publically available specification
SLAM	Simultaneous Localisation and Mapping
UAV	Unmanned aerial vehicle

2.4 Sources of information

Table 2-1 lists the datasets that have been used during this research project to develop illustrative BIM datasets. With the exception of some material already available at Ramboll on Iron Bridge, all datasets were provided by HE.

Table 2-1 Datasets provided for Harmondsworth Barn and The Iron Bridge

Site	Type	File Format(s)	Source date	Description
Harmondsworth	Point cloud	XYZ (zipped)	May 2014	Cyark
Harmondsworth	Point cloud	POD, E57, FLS	March 2015	Post conservation
Harmondsworth	Point cloud	FLS	June 2013	Pre conservation
Harmondsworth	Point cloud	FLS	November 2012	Pre conservation
Harmondsworth	Documents	PDF,DWG,JPG	N/A	Various reports, spheroidal imagery
Harmondsworth	Photogrammetry	JPG,PSZ	November 2012	Photogrammetry
Iron Bridge	Point cloud	POD,FLS,TXT	February 2012	Iron-Bridge
Harmondsworth	Photogrammetry	JPG,PSZ,TXT	November 2012	Photogrammetry plinths
Harmondsworth	Report	PDF	Jan 2012	Condition survey
Iron Bridge ⁽¹⁾	3D model	3DM	March 2013	Strength assessment model
Harmondsworth	Point cloud	LAS. PLY, TXT	June 2016	Handheld laser survey
Notes				
1. This model was already available within Ramboll following an earlier project on The Iron Bridge				

2.5 Software

Table 2-2 lists the modelling software packages that have been used to develop the datasets provided for Harmondsworth Barn and The Iron Bridge.

Table 2-2 Modelling software used to develop datasets

Software Name	Version(s)	URL	Notes/Uses
Autodesk Revit	2015 & 2016	http://www.autodesk.co.uk/products/revit-family/overview	
Autodesk ReCap 360	Pro Photo to 3D A360 Meshing Real View	http://www.autodesk.com/products/recap-360/overview	Pro is desktop app to import and edit datasets Photo to 3D is a cloud based photogrammetry software A360 meshing is a cloud based software to automatically mesh point cloud data Real View is a panoramic view of each laser scan
Autodesk ReMake		https://remake.autodesk.com	Used to view and edit multi-million triangle 3D meshes
Autodesk 360	N/A	https://a360.autodesk.com/	Cloud storage and model viewing
Rhinoceros	5 SR 13	https://www.rhino3d.com/	3D modelling
Bentley Pointools V8i	Select Series 1	https://www.bentley.com/en/products/product-line/reality-modeling-software/bentley-pointools?skid=CT_PRT_POI_NTOOLS_B	Point cloud editing, rendering

Software Name	Version(s)	URL	Notes/Uses
CloudCompare	2.7.0	http://www.danielgm.net/cc/	Cloud to cloud comparisons, colouring REVO data
Edgewise BIM Suite	5	http://www.clearedge3d.com/products/edgewise-bim-suite/	Automatic 3d modelling & export to Revit
Pannellum	2.2.0	https://pannellum.org/	Open source web hosted panoramic image viewing software
ArcGIS Online	N/A	https://www.arcgis.com/home	Web based GIS tools
Adobe Photoshop	CS 2015	http://www.adobe.com/uk/products/photoshop.html	Photo editing, batch processing
In-house software	N/A	N/A	Point cloud processing including sampling, histograms, intensity normalisation and contouring. Panoramic viewer using WebGL and HTML5.

2.6 Models produced

Various models of the two sites have been developed to help illustrate different aspects of BIM, for instance different levels of detail, and these are listed in Table 2-3 and Table 2-4. These models have also been issued electronically to HE.

Table 2-3 Models developed for Harmondsworth Barn

File name	Format/type	Description
Harmondsworth-Barn.rvt	Revit 2016 model	Sample model of bays 11 and 12 of the barn to a LoD 2 (see Table 8-2 in the report 1620001834-R01)
Block Model.3dm	Rhino 5 model	Sample 3d model to LoD 1 (see Table 8-2 in the report 1620001834-R01)
Harmondsworth.rvt	Revit 2016 model	Unfinished Revit model of 2 bays to LoD 3 (see Table 8-2 in the report 1620001834-R01). Medium Detail Model.3dm supersedes this model.
High Detail Model - joint.3dm	Rhino 5 model	Sample 3d model to LoD 4 (see Table 8-2 in the report 1620001834-R01)
Medium Detail Model.3dm	Rhino 5 model	Sample 3d model to LoD 3 (see Table 8-2 in the report 1620001834-R01)
Mesh Test-C-ZZ-OSO-MLS-DN-R1.rcm	ReCap Mesh	3D automatic mesh of a half-frame, created from REVO data
Harmondsworth Plinth.rcm	ReCap Mesh	3D mesh generated by ReCap 360 Photo to mesh service
revo-model.3dm	Rhino 5 model	Test model of a sample area of the barn from the REVO data

Table 2-4 Models developed for The Iron Bridge

File name	Format/type	Description
Iron Bridge.ifc	IFC 2x3 model	Export of the Rhino model to IFC format
Iron Bridge.rvt	Revit 2016 model	Revit format version of the Iron Bridge model
The_Iron_Bridge_Full_Model.3dm	Rhino 5 model	Rhino model of the bridge

File name	Format/type	Description
The_Iron_Bridge_Full_Model.dwg	AutoCAD model	AutoCAD export of the Rhino model above
Iron Bridge Hybrid Model Demo.rvt	Revit 2016 model	Revit model referencing the ReCap point cloud, with 2 model objects: a repair detail and a cuboid used to contain relevant to information
BlockModel.3dm	Rhino 5 model	Sample 3d model to LoD 1 (see Table 8-5 in the report 1620001834-R01)
LOD2.3dm	Rhino 5 model	Sample 3d model to LoD 2 (see Table 8-5 in the report 1620001834-R01)
LOD3.3dm	Rhino 5 model	Sample 3d model to LoD 3 (see Table 8-5 in the report 1620001834-R01)

3. BACKGROUND

3.1 CAD

CAD software such as Autodesk AutoCAD(1) allows users to draw lines, arcs, circles, splines etc such that technical drawings can be created. This was originally limited to 2 dimensions, but nowadays most CAD software is 3D, enabling users to create 3 dimensional surfaces and solid objects. This allows a more complete picture of the design intent to be realised and tested prior to construction.

Over the last decade a new technology has emerged whereby a survey is carried out with an instrument that uses a laser to accurately measure hundreds of thousands of points every second. The resulting dataset, comprising millions, or even billions of individual x, y and z coordinates is called a point cloud. When viewed in a CAD system, the point cloud has so many points and is so dense that objects appear solid. CAD systems that support it, allow users to create 2D and 3D features by directly interacting with the point cloud.

One of the biggest issues with using point cloud data in a heritage context is that building a CAD model from it is a manual, time consuming and therefore costly task. More recently new tools that can automatically or semi-automatically extract geometry from a point cloud have been released. Whilst these tools are promising, they are very much in their infancy and are not necessarily applicable to heritage projects, where features are non-uniform and often unique.

A middle ground has been proposed, called Hybrid Modelling where the point cloud and CAD can be used in conjunction with each other. In this process the point cloud data, which may have been created in a number of ways, would form the baseline and new CAD data can be added to show the intent of new works such as repairs or replacements. Accordingly the point cloud can be edited to remove the now defunct points. The process is much faster and cheaper as only what is necessary is modelled. The decisions required to simplify geometry for CAD creation are also avoided.

Although point clouds are generally associated with 3D laser scanning surveys they are also produced by other measurement and modelling techniques, for instance digital photogrammetry, bathymetric acoustic surveys, and ground penetrating radar. These point clouds may have different densities because of the different physics involved in measurement, but can be used and processed all in the same way.

Another form of hybrid CAD involves automatically meshing the point cloud with triangular surfaces between sets of 3 points. The number of triangles in the resulting mesh is often too large for CAD software to use but this can be reduced, lowering the accuracy of the resulting 3D model, but making it easier to use in CAD software. Some software that specialises in this task can optimise the mesh reduction such that flat areas get larger facets whereas a feature such as an edge fillet will get smaller facets. This method creates a model that can be more easily

manipulated in CAD software than working with point clouds but some geometry approximation is involved.

The use of CAD systems to aid the design and conservation process is now fairly common place on heritage projects. However Hybrid modelling is not yet wide spread mainly because major CAD systems do not fully support this method of working.

3.2 BIM

It has been found that existing processes to develop our built environment are confusing, poorly co-ordinated, un-structured often unnecessary, and design/construction information difficult to find. Buildings are typically designed, redesigned and constructed with poor handovers of information and with many repeated activities. It has been shown that this can add 20-25% to costs, and it has been recognised for some time that more clarity in these design processes would lead to more efficiency, which would lead to reduced cost and construction time.

BIM is the name given to these improved processes. BIM includes both non-graphical (spreadsheets, databases) and graphical (2D drawings, 3D geometry models) information linked through a common data environment, and used by all parties to create an easily accessed environment for collaboration.

In attempting to adopt BIM it was recognised from the outset that considerable effort would be required so that processes would adopt a standardised philosophy so that true collaboration would be possible. With this aim, a BIM task group was set up by the UK government to set out a construction strategy and embark on a programme of activities for the industry to adopt BIM. According to the BIM Task Group:

- BIM is essentially value-creating collaboration through the entire life cycle of an asset, underpinned by the creation, collation and exchange of shared 3D models and intelligent, structured data attached to them.
- The Government Construction Strategy was published by the Cabinet office on 31 May 2011. The report announced the government's intention to require collaborative 3D BIM (with all project and asset information, documentation and data being electronic) on its projects by 2016. Essentially the UK government has embarked with industry on a four year programme for sector modernisation with the key objective of reducing capital cost and the carbon burden from the construction and operation of the built environment by 20%. Central to these ambitions is the adoption of information rich Building Information Modelling (BIM) technologies, process[es] and collaborative behaviours that will unlock new, more efficient ways of working at all stages of the project life cycle.

Moving to BIM would be undertaken in stages depending project complexity and value, and the technology maturity of the organisations involved. Understanding that this would be the case different BIM maturity levels were defined to help manage the transition from established processes. These different BIM maturity levels including the associated principal standards are shown in Figure 3-1.

The government strategic objective has been set to achieve maturity Level 2 BIM on all public sector asset procurement, with equal applicability to private sector building, infrastructure, and refurbishment and new-build projects. PAS 1192-2:2013(2) *Specification for information management for the capital/delivery phase of construction projects using building information modelling* defines BIM Level 2. A summary of the key initial activities required to lead to collaborative working in an information management framework, and that aims to achieve the government objective in a standardised way, are as follows.

- Provision of employer's information requirements (EIR)(4)
- Development of BIM execution plan (BEP)
- Provision of a single environment to store shared data and information

- Information developed using a combination of discipline-based software with varying degrees of interoperability.

In Figure 3-1 the red line indicates the government target maturity level to be achieved for 2016.

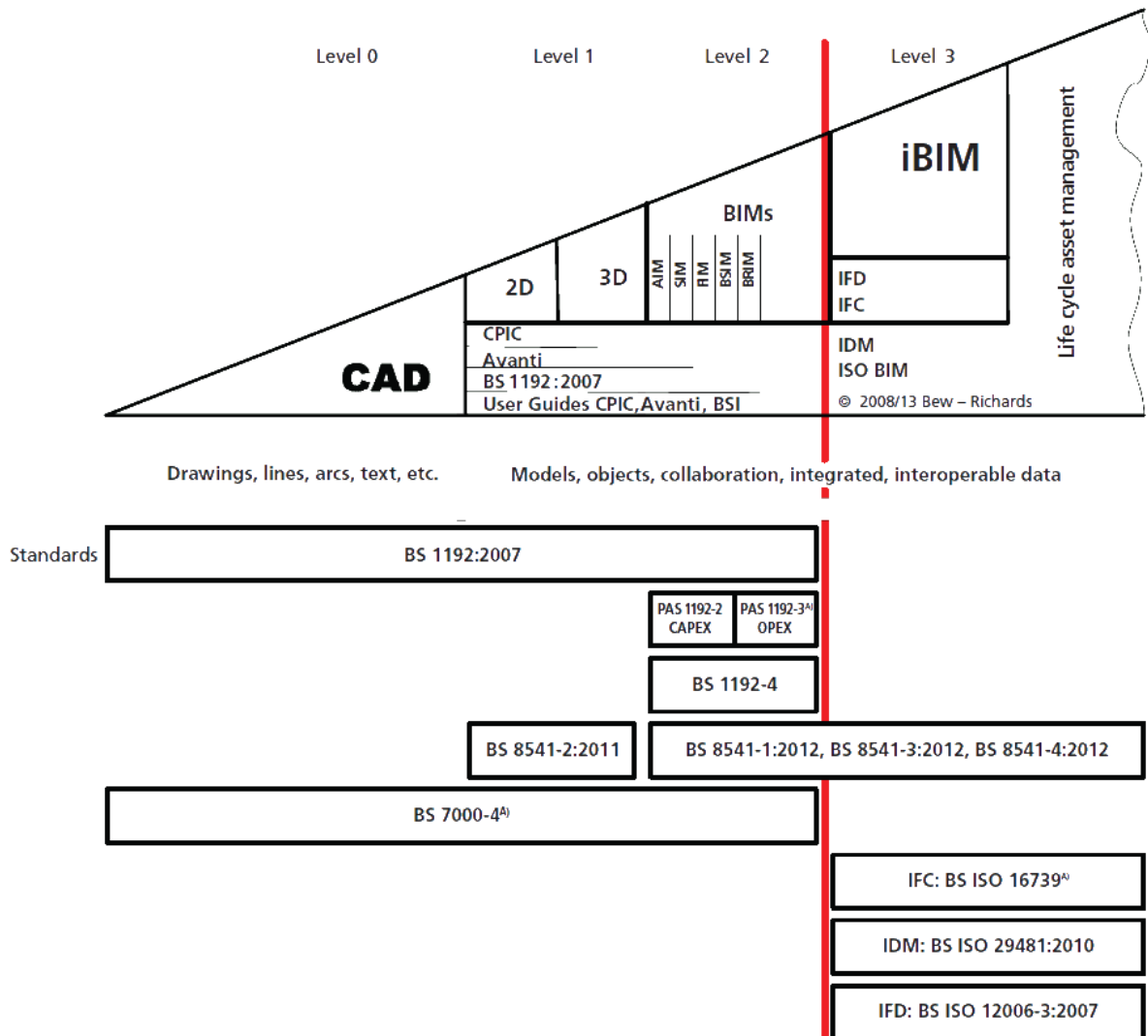

Figure 3-1 BIM maturity levels (reproduced from PAS 1192-2:2013)

4. NEW BUILD

4.1 Construction

BS 1192(5) *Collaborative production of architectural, engineering and construction information - Code of practice* predates most BIM guidance. Recognising technology enabled processes it aimed to set standards to aid automation of drawing and document production processes, indexing and searching project material, filtering and sorting, and quality checking and document comparisons. Perhaps the key objective was to set a CDE based on standard folder and file naming conventions, and common metadata.

The specification for information management for the capital/delivery phase of construction projects using BIM is set out in PAS 1192-2:2013. Although this is geared towards standalone new-build projects there is acknowledgement that the same processes can be used for parts of estates and existing structures and buildings. This is indicated by different starting positions in the project life cycle shown in Figure 4-1. New-build starts in the blue box labelled NEED which is also the start of CapEx (cost of developing a new asset). Existing assets would be subject to the

processes starting at the blue box marked ASSESSMENT and within the OpEx (operational expenditure covering the ongoing cost of running/maintaining an asset) period.

The intended audience for this PAS are organisations responsible for the procurement, design, construction, delivery, operation and maintenance of buildings and infrastructure assets. The PAS sets out the different information delivery stages starting with Assessment and Need. By progressively working through the various stages of the information delivery cycle, the requirements within this PAS culminate in production completion and the as-constructed asset information model (AIM).

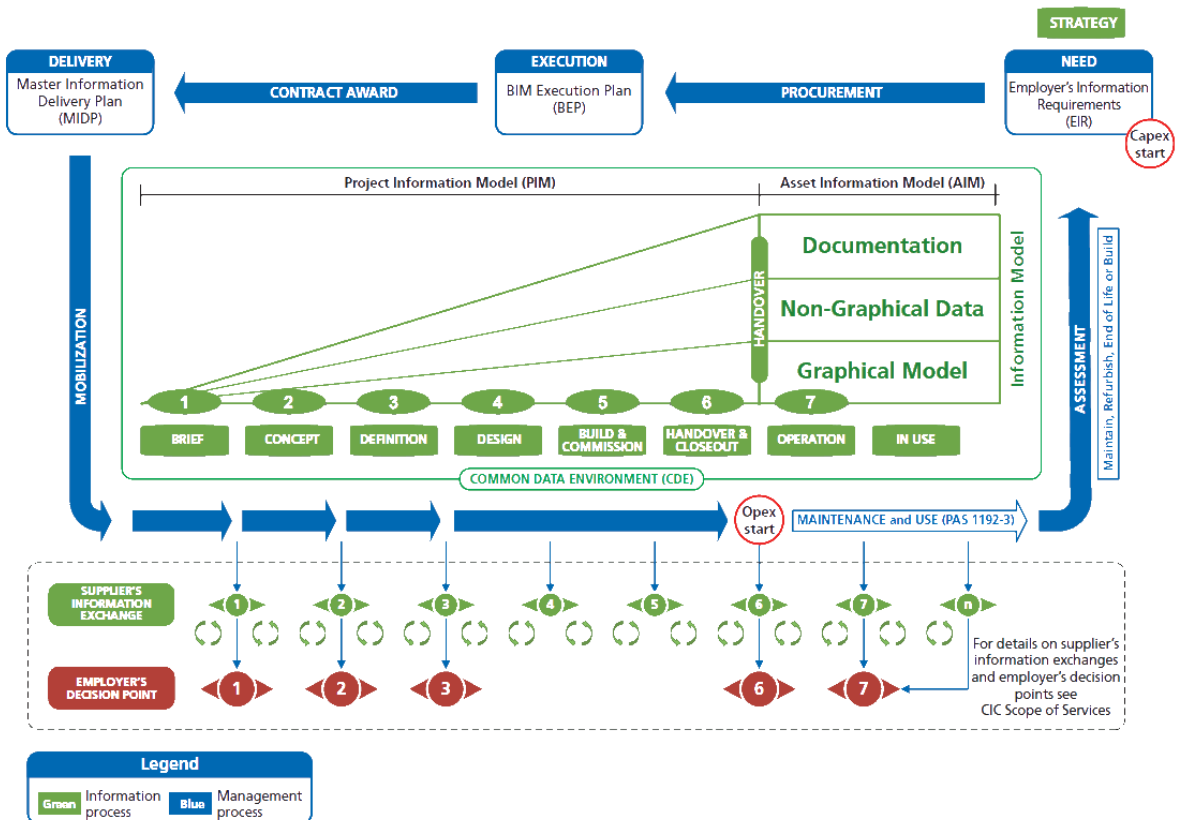

Figure 4-1 Information delivery cycle (reproduced from PAS 1192-2:2013)

A simplified form of the information delivery cycle, based on the Construction Industry Council (CIC) scope of services project stages, produced by COTAC(6), is shown in Figure 4-2. PAS 1192-2 covers the construction stages 1 to 6 leading to handover. Stage 7 is concerned with the operation of the asset, which is more relevant to the maintenance and operation processes of heritage assets, and is discussed in Section 4.2.

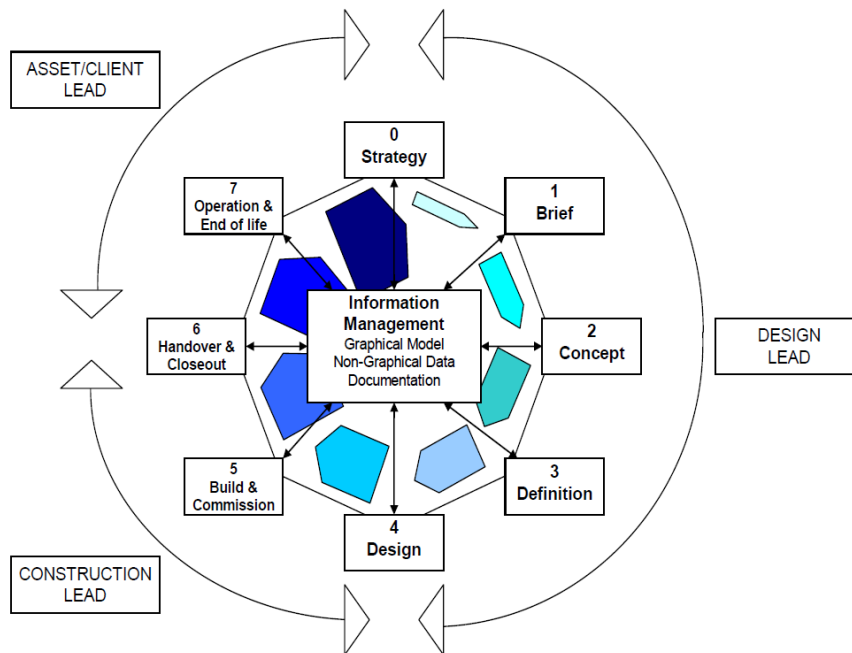

Figure 4-2 CIC BIM Cyclic diagram

4.1.1 Industry Foundation Class

Industry Foundation Classes (IFC) are all about sharing of information between project team members and across different software applications used for design, construction, procurement, maintenance and operations. BuildingSMART(7) has developed a common open data file format (IFC) that makes it possible to hold and exchange relevant data between different software applications. The aim is to facilitate interoperability in the architecture, engineering and construction industry, and is a commonly used collaboration format in BIM. The IFC model specification is open and available and is registered by ISO and is an official International Standard ISO 16739:2013. Various file formats have been developed.

4.2 Asset Management

The specification and principles for information management for the operational phase of assets using BIM is covered by PAS 1192-3:2014(8) *Specification for information management for the operational phase of assets using building information modelling*. The operational phase of an asset follows on from the construction phase as set out by PAS 1192-2:2013 and is marked by the handover of the Project Information Model (PIM). In some respects the PIM describes the initial conditions for the management of the asset which is then developed through the life of the asset and evolves into the Asset Information Model (AIM). Clearly, the effective use of BIM in the operational management of a new asset will be greatly influenced by the availability and integrity of the AIM.

An obvious difference between the construction and asset management phases is that more flexible sequences of activities are required throughout the asset life cycle, whereas, construction according to PAS 1192-2 is able to follow a clear sequence of project stages. Asset management as described by PAS 1192-3 applies across a mixture of planned and unplanned events in the life of an asset that can happen in any order between handover and disposal. Of course in the context of a heritage, asset disposal is less likely to be an option. To reflect this the information delivery cycle developed for construction is adapted for asset management and is shown in Figure 4-3.

The AIM first inherits the PIM and then during operation of the asset may include maintenance, minor and major works activities, and even include change of ownership. These activities are

indicated in the asset management delivery cycle by green ellipses marked "n". Major works, such as a new building in an estate, could spawn a new construction cycle and supplementary PIM which in due course would be adopted by the AIM.

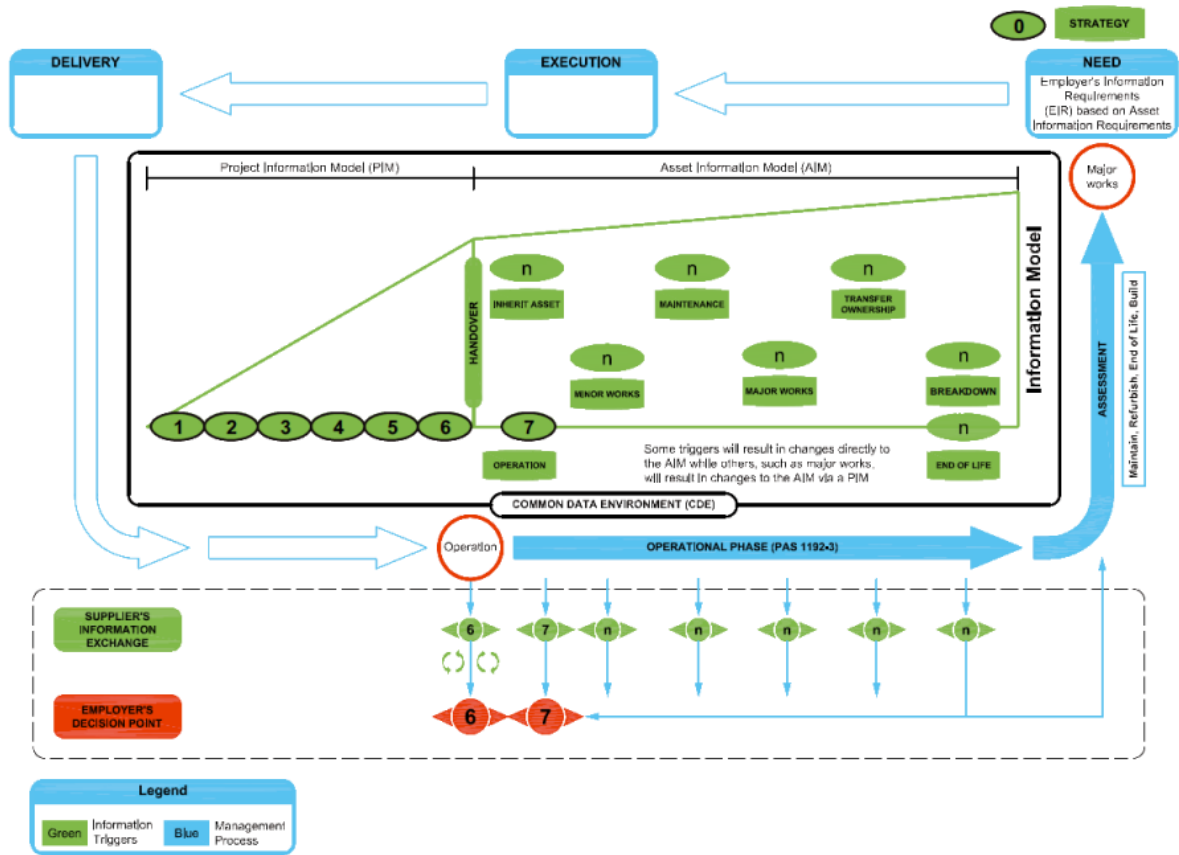

Figure 4-3 Asset management delivery cycle (reproduced from PAS 1192-3)

5. EXISTING ASSETS

It is very unlikely that existing assets will have non-graphical and graphical information set up electronically in a way that immediately aligns with the requirements of PAS 1192-3. In other words an AIM does not exist. This is even more likely the case with heritage assets which are likely to have associated documentation filed in many traditional formats that have been accumulated over many years and stored in various locations. However, it is likely that large estates will be using modern asset management systems although these are most likely holding non-graphical information which is not linked to a spatial and/or positioning environment. It is understood that English Heritage are successfully operating a large estate asset management system and this is briefly discussed in Section 6.2.

Although PAS 1192-3 advocates the use of BIM even when an AIM is not available, little advice is provided on how this can be achieved. In New-build BIM the PIM develops by following the CIC BIM staged processes with little additional overhead and culminates at handover by providing the AIM from which the asset management systems (referred to as linked enterprise systems in BIM standards) can be integrated. This is shown in Figure 5-1 reproduced from PAS 1192-3. Information is then pushed and pulled between the AIM and asset management system.

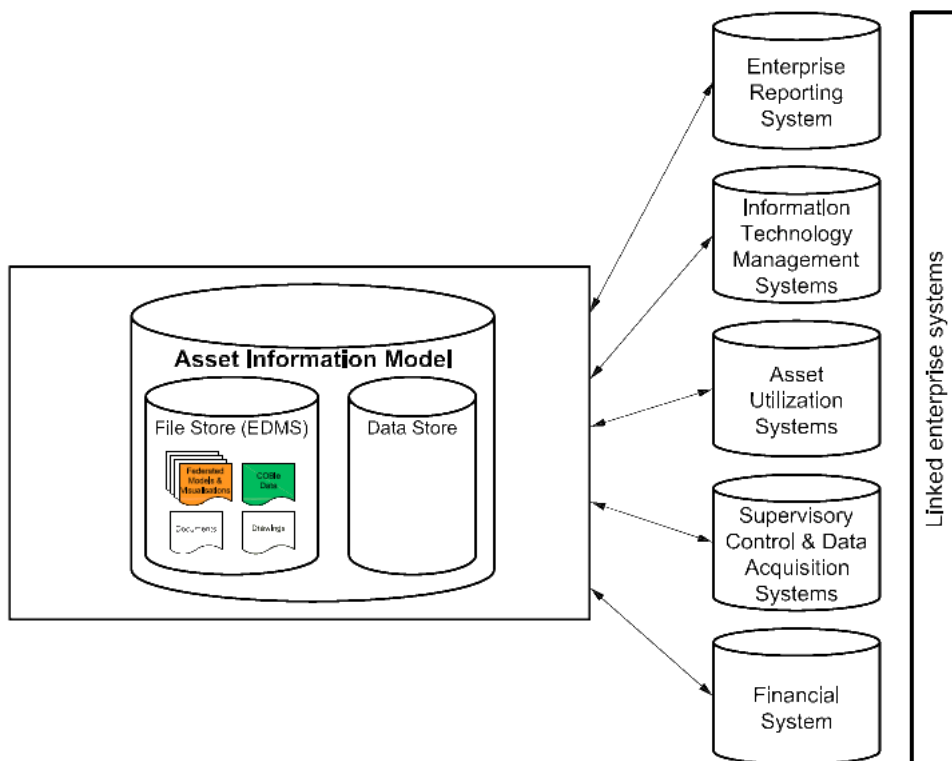

Figure 5-1 Relationship of AIM with asset management systems

For existing assets there is potentially a massive overhead in establishing an AIM at the same fidelity expected from new-build. To be cost effective the level of model definition, discussed in Section 7, has to be established that is sufficient for the envisaged operational processes. This will involve the organisation of some kind of graphical data, and measurement and modelling activities the extent of which could vary enormously depending on the value and operational complexity of the asset. For instance, the graphical data could comprise a simple 3D geometry model indicating spatial relationships and linked to non-graphical information, or could be a highly detailed 3D model developed from a precisely measured point cloud including detailed 3D objects with many volumetric and positional attributes and many two way links to external non-graphical information.

The challenge for existing assets is pitching the level of model definition used for BIM for the envisaged asset management processes as and when required. For Heritage assets this is even more challenging because of their significance, complexity and demanding financial constraints.

6. HERITAGE ASSETS

6.1 Conservation emphasis

COTAC(6) have suggested adapting the CIC BIM cyclic diagram for application to heritage assets with stage headings slightly altered to reflect a conservation emphasis. This is reproduced in Figure 6-1.



Figure 6-1 Emerging HBIM framework cyclic diagram

An exercise of correlating conservation topics with the CIC construction stages was also proposed. The correlation articulates, perhaps for the first time, the headline topics that have to be considered in the continued conservation of heritage assets in a way that directly maps to the construction stages that are becoming well established in New-Build BIM. The resulting diagram is shown in Figure 6-2.

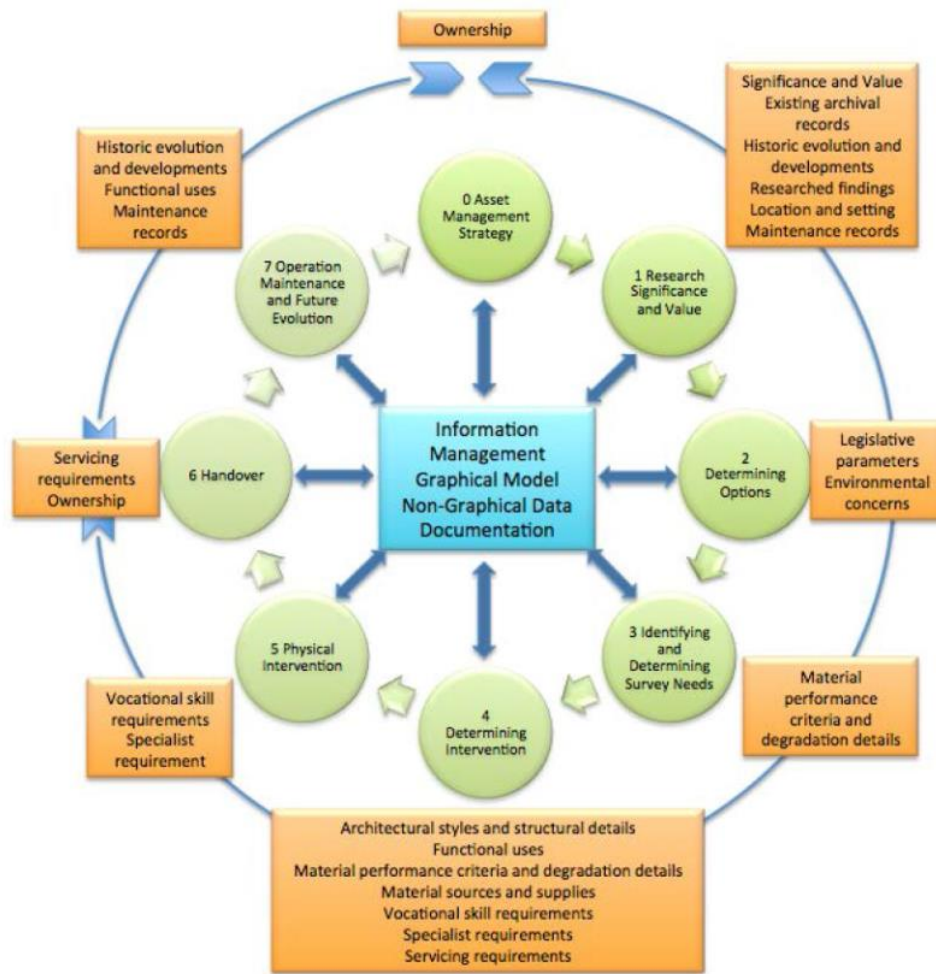

Figure 6-2 Proposed heritage topics mapped to CIC stages

In many respects the whole cycle shown in Figure 6-2 corresponds to stage 7 in the CIC BIM cyclic diagram and the activities shown would be repeated for ongoing conservation and maintenance, as well as for distinct and more major conservation projects.

6.2 English Heritage asset management system

The English Heritage (EH) Conservation Maintenance Programme (CMP) 2015/16 to 2022/23(9) gives some information on the K2 asset management system that is currently being used. As explained in Section 5 the integration of the asset management system with BIM is an important aspect of the wider implementation of BIM across an estate. Unfortunately, it has not been possible to discuss the operation of K2 with the AMP National Survey Manager, but the following information based on the CMP gives headline capabilities and how it is used.

K2 is produced by Tribal, is a database system, an off-the-shelf product and has been implemented with some bespoke development for EH. It is an interactive and integrated facilities asset management system. It is modular with 24 modules and those key to EH operations are Condition (to capture survey data), Maintenance (preventative maintenance tasks and scheduling) and Help Desk (captures and tracks response). CAD and GIS modules are available which may be relevant to the adoption of BIM but it is not known whether these are being used.

The adoption of K2 has been the final step in a process spanning several years to fully survey all 400 plus historic sites using a standard condition survey. In effect, this has loaded the K2 database so that it has become a virtual estate. This is now being used to plan maintenance and forecast funding scenarios.

The integration of BIM with existing K2 datasets would seem to be a logical direction to go, but it has not been possible, nor is it within the scope of this study, to discuss the feasibility of this in this report.

7. LEVEL OF MODEL DEFINITION

7.1 General

Establishing the appropriate level of model definition (LoMD) and how this is linked to the asset management system are the key factors that have to be considered in order for BIM to be useful and cost effective. Within this section the standardisation that has been developed for new-build, and the emerging guidelines focused on heritage assets are reviewed.

Proposed methods of dealing with the two parts of LoMD for heritage assets are presented in Section 8 and Section 9. The two parts of LoMD as developed for new-build are now explained.

7.2 New-build

For new-build, LoMD are progressively refined in relation to advancing CIC construction stages, and defined as a combination of level of information (LoI) and level of detail (LoD). LoI relates to non-graphical information, and LoD refers to level of graphical information. This relationship could be expressed as a virtual equation.



$$\text{LoMD} = \text{LoD} + \text{LoI} = \text{function (CIC stage)}$$



The logic behind separating these two sets of levels is that the graphical appearance of assets and contained objects can be completely independent of the associated information. For instance a symbol indicating location might be all that available for LoD, but with a linked detailed specification, cost schedule and manufacturing data providing a high LoI. So a further relationship may, but not always, be as follows.

$$\text{LoD} \neq \text{function (CIC stage)} \text{ and } \text{LoI} \neq \text{function (CIC stage)}$$

Table 7-1, partly reproduced from PAS 1192-2, uses a simplistic building to help illustrate different LoMDs.

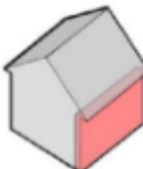
Table 7-1 Level of model definition, new-build simple illustrations

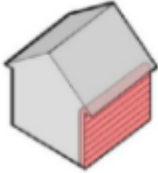

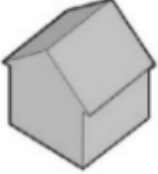
LoMD	Visual example	How the model can be used
1		Model information communicating the brief, performance requirements, performance, and site constraints
2		Models which communicate the initial response to the brief, aesthetic intent and outline performance requirements. The model can be used for early design development, analysis and co-ordination.
3		A dimensionally correct and co-ordinated model which communicates the response to the brief, aesthetic intent and some performance information that can be used for analysis, design development and early contractor engagement.

LoMD	Visual example	How the model can be used
4		A dimensionally correct and coordinated model that can be used to verify compliance with regulatory requirements. The model can be used as the start point for the incorporation of specialist contractor design models and can include information that can be used for fabrication, co-ordination, sequencing and estimating purposes.
5		An accurate model of the asset before and during construction incorporating co-ordinated specialist subcontract design models and associated model attributes. The model can be used for sequencing of installation and capture of as-installed information
6		An accurate record of the asset as a constructed at handover, including all information required for operation and maintenance.

7.2.1 Level of Detail

Although PAS 1192-2 establishes LoMD and provides examples, little advice is given individually on either quantifying or visualising LoI and LoD. However, the AEC (UK) BIM Protocol committee(10) do provide a grading system for LoD as reproduced in Table 7-2. In some respects the authors of this system appear to be concerned with appearances on drawings and so graphical scale features in defining how much detail is contained in objects. This may be useful in gaining some understanding of the concept, but given that BIM and LoD relate to a virtual model in a true coordinate system, scale and the inferred drawing space is irrelevant.

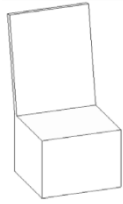
Table 7-2 AEC (UK) BIM Protocol suggested Levels of Detail (LoD)

Grade	Visual example	Description
G0	Chair	Symbolic (not representative of the physical object) This might be used for electrical symbols or an object which is modelled the same regardless of scale
G1		Low resolution conceptual placeholder (e.g. 1:500, 1:200)
G2		Medium resolution detailed component for design/construction (e.g. 1:100, 1:50 max)

Grade	Visual example	Description
G3		High resolution, fully detailed object. Typically only used for visualisation.

Hence, LoD is level of model resolution ranging from a symbolic place holder to a virtual prototype suitable for manufacture.

LoD = function (Modelling fidelity)

The NBS(11) have produced more detailed guides on LoD and LoI and the interaction between them. LoI is discussed in more detail in Section 7.2.2. An example of the NBS suggested Levels of Detail is shown in Table 7-3.

Table 7-3 NBS suggested Level of Detail

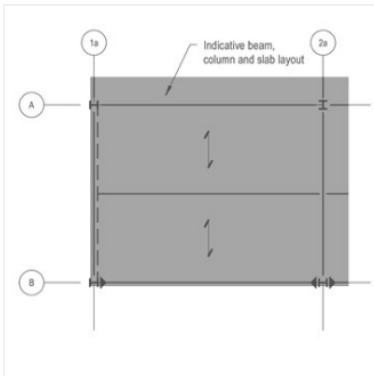
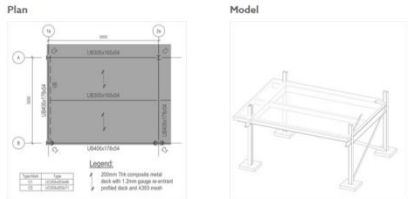
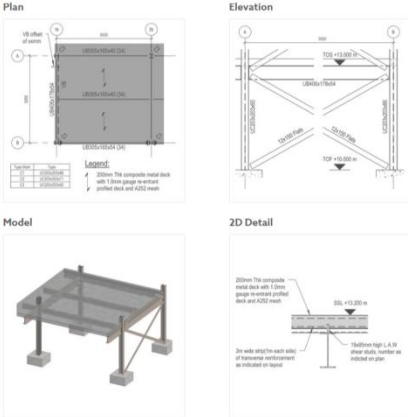
LoD	Visual example	Description
2	<p>Plan</p> 	A visual representation of the concept design showing the proposed arrangement and its relationship to surrounding context.
3	<p>Plan Model</p> 	As above but now with more developed principles of the design in higher detail. It is expected by this stage to be coordinated with other disciplines, as well as showing the spatial relationship between the elements to be constructed. This LoD could form a brief for a specialist contractor to develop a detailed design for fabrication.
4	<p>Plan Elevation</p> 	As above except now the design should be ready for procurement. The model should be dimensionally accurate indicating primary performance characteristics. It would be coordinated with other disciplines. Likely would include drawings showing setting out, loading and installation details.

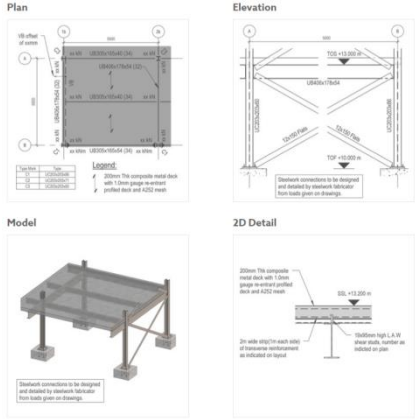
LoD	Visual example	Description
5	 <p>The visual examples for LoD 5 include: <ul style="list-style-type: none"> Plan: A top-down view of the steel structure with dimensions and annotations. A legend notes: '2D shows the composite steel deck with three-ply concrete profiled deck and A325 nuts'. Elevation: A side view showing the structural members and their connections. A note states: '2D shows connections to be designed and detailing shown in separate from each plan or drawing'. Model: A 3D perspective view of the steel structure on supports. A note states: '2D shows connections to be designed and detailing shown in separate from each plan or drawing'. 2D Detail: A close-up view of a connection point. Annotations include: '2D shows the composite steel deck with three-ply concrete profiled deck and A325 nuts', '2D shows connections to be designed and detailing shown in separate from each plan or drawing', and '2D shows height L.L. & H.H. steel deck, shown as indicated on plan'. </p>	<p>As above except now the design is ready to support construction. The model should be fully coordinated between all parties. Model should be dimensionally correct including enough supporting drawings for manufacturing each element of the design. Supporting drawings and details to support setting out and installation.</p> <p>The LoD 5 model should be updated throughout construction to reflect the as-built condition and in so doing enable the handover of an AIM.</p>

7.2.2 Level of Information

PAS 1192-2(2) describes LoI as the description of non-graphical content of models at each of the stages defined for example in the CIC Scope of Services, but is a little vague about the actual non-graphical information that is expected.

In general terms the LoI covers subjects such as what the BIM can be expected to be relied upon at each CIC stage including, output, parametric information, critical interfaces, construction requirements, project costs, project logistics and off-site activities, project facilities (welfare, IT infrastructure, security etc.) on site and off site, and notes and associated project documents.

The NBS(3) describes LoI by looking at a brick wall. The geometry of the BIM model would only include the height, length and width of the wall. The information associated with the wall object would explain everything else about that wall such as the type of brick used including its strength, density or the properties of the mortar.

The BIM Task Group(4) state that as part of the appointment for a BIM project the employer would supply the EIR, which should set out what models need to be produced, to what LoD and LoI, and at what stages of the project these are required. As such for New-build BIM it is up to the client to determine what information is required in the model.

The NBS LoI examples for the same steel structure as shown in Table 7-3 are summarised in Table 7-4, below.

Table 7-4 NBS suggested Level of Information

LoI	Description
2	An outline description of the design intent.
3	More detailed information relevant to the performance of the design such as design criteria, loading data and standards requirements.
4	At this stage the information should start identifying the type of products that could be used, such as the type of steel sections, typical connection products, fixings, flooring type and movement joints.
5	At this stage the information should be complete enough such that the contractor can procure and construct the elements. Information includes section sizes and quantities, connection details, fixings.
6	For this stage the model and its information is ready for handover for client operation. As such information should include user manuals, maintenance details, warranty details, expected life, manufacturer, part numbers, material, finish, colour, bar codes etc.

7.3 Heritage Assets

With heritage assets the effective use of BIM is far more complex than new build and the benefits less obvious.

- In new-build a BIM model naturally evolves by following the CIC stages and a PIM then AIM is handed over to become the chief resource for asset management. There is no AIM for existing heritage assets.
- The asset exists and some amount of measurement is required to provide geospatial context and graphical information
- Some sort of modelling process will need to be carried out based on the graphical information to build the AIM
- There is less opportunity to reuse modelled objects as these are more likely to be unique
- Information already exists in many forms, possibly stored in different locations and in various formats
- The significance of assets will vary and the budgets and processes for conservation scaled accordingly
- The benefits of a BIM framework and the selection of LoMD to collate new information will need to be evaluated, initially but also for ongoing conservation projects

It is clear that LoMD of heritage assets cannot relate to construction stages as the heritage aspect of building has already been completed, but there are similarities with new-build LoD and LoI. The LoMD for heritage assets will still be a combination of LoD and LoI. However, each may take different levels based on other factors such as significance. For instance, a heritage site may have a low LoD but high LoI. LoMD could also apply in a similar way to new-build to alterations to historic assets, be it introduction of new elements, refurbishment/addition of new build elements. There are lots of 'hybrid' interventions in which new developments happen within historic assets.

LoD relates to the modelling detail used for graphical information and is true for both new-build and heritage, except that for heritage there is an extra activity requiring measurement. Similar LoI covers both new-build and heritage, but the information is different. For instance, for new-build information might include a performance specification for new equipment whereas for heritage this could be a catalogue of previous conservation activities.

The following sections consider the emerging guidelines for BIM on heritage assets and other metrics that are likely to be important in developing LoD and LoI usage guidelines for BIM. Section 8 considers how a LoMD could be developed for heritage assets.

7.3.1 Level of Detail

The Metric Survey Specifications for Cultural Heritage(12) produced by HE describes the general requirements for various types of metric survey, and provides standards specific to image-based, measurement and topographic surveys as well as standards for laser scanning and BIM. The aim of the Chapter on BIM is to provide a specification for the creation of a BIM-ready dataset. Unlike the New-build standards this specification includes the required level of geospatial measurement data that has to be captured to achieve different LoDs, and as a simple equation.

LoD = function (measurement fidelity)

Table 7-5 reproduces the four LoD definitions given by the Metric Survey. If required, a further level is indicated which if used should be accompanied by a separate LoD description.

Table 7-5 Historic England Metric Survey suggested Levels of Detail (LoD)

Level	Description
1	basic outline of the building/structure represented as a solid object using representative component information but with no architectural detail depicted
2	outline of the building/structure represented as a solid object with principal architectural features included using generic components
3	outline of the building/structure represented as a solid object with all architectural features and

	major service detail included using generic components
4	detailed survey of the building/structure represented as a solid object including all architectural detail, services and custom developed components to accurately represent fabric type
Other	Specify

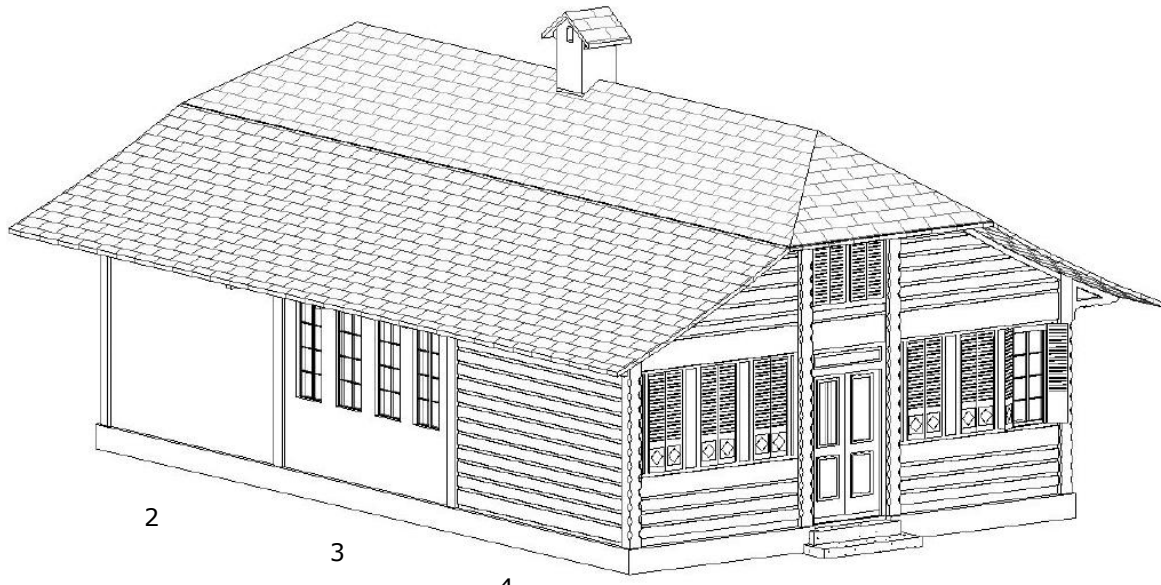

Equal thirds of the building developed to Levels 2, 3 and 4 as indicated

7.3.2 Level of Information

As has been discussed, the LoI for new-build like LoD tends to follow the CIC stages although it is accepted that this may not always be the case with, for example, low LoD and high LoI is possible. Within a heritage context, accepted recommendations for mapping out different levels of LoD for BIM do not yet exist and like LoD are likely to be more variable and complex than those for new build. However, progress is being made, and COTAC(13) have begun to identify a range of issues and influences that should be considered in the development of BIM for heritage. These will be considered in more detail in considering an approach to LoI for heritage in Section 9.

7.3.3 Heritage Significance

Unlike new-build and ordinary existing assets the heritage significance of an asset is another factor that could be used to determine appropriate LoMD, LoD and LoI when using BIM. The English Heritage classification for buildings is reproduced in Table 7-6. This will be considered in the proposed classifications described in Section 8.

Table 7-6 English Heritage classification for buildings

Grade	Description
I	Grade I (one) indicates that the building is of "exceptional interest"
II*	Grade II* (two star) indicates that "buildings are particularly important...of more than special interest"
II	Grade II (two) indicates that buildings are "of special interest, warranting every effort to preserve them"

8. HERITAGE - LEVELS OF DETAIL

8.1 General

As stated in Section 7.2, LoMD for new-build follows closely the CIC construction stages although the development of LoD and LoI considered individually may vary. For heritage assets, as the

construction is complete, LoMD will vary according to the type of asset, the significance of that asset, and the management and conservation processes that are required. There is no AIM and any kind of modelling to represent the graphical information will, therefore, require one or more measurement surveys to develop the required LoD for the planned BIM environment. Many surveying technologies are available and their specification for heritage work is provided by the Metric Survey Specification(12). To assist in the selection of survey for varying levels of LoD a survey classification system has been proposed as part of this work and this is described in Section 8.2.

Using examples developed from the datasets of both The Iron Bridge and Harmondsworth Barn, models taken from selected parts of the datasets have been developed to show different LoDs. The different levels broadly correspond to those in the Metric Survey Specification and are described in Section 8.3.

8.2 Classification of surveys

To develop appropriate LoD for heritage BIM applications, different survey technologies have been classified. The technologies chosen are those known to be most amenable to 3D geometry modelling, although can still be used for 2D work, and generally involve point clouds. The classification system is shown in Table 8-1, and is based on indicative cost bands, measurement range, and cloud density. Potential uses are also listed.

Table 8-1 Classification of survey techniques and processes

Class	Process (example equipment)	Range [m] (typical point cloud density [mm])	Typical Cost	Potential Uses
L0	Laser measuring (1D) device (Leica DISTO D1)	0.2 – 30 (≤3 discrete measurements)	Low	Sketches and 2D drawings (typically plan only)
L1	Ground based photogrammetry	1 – 20	Low	Facades, impressions of surface features/sculptures, simple building forms
L2	UAV based photogrammetry	5 – 50	Low	3D site topography, roofs, building footprints/layouts
L3	Low resolution, medium range handheld laser scanners (GeoSLAM Zeb-Revo)	2 – 30 (≤10)	Low	3D building interior layout, close range externals
M1	3D Topographical survey	2 – 200	Medium	3D site topography, ground level services, building footprints/layouts, floorplans
M2	High resolution, close range handheld laser scanners (Faro FreeStyle)	0.1 – 2 (≤1)	Medium	Small scale, local details where high detail is needed
M3	Static tripod supported laser scanners (Z+F Imager 5016)	2 – 150 (≤5)	Medium	3D site topography, complex building forms,
M4	Long range static tripod supported laser scanners (Riegl VZ-6000)	100 – 6000 (≤100)	Medium	Terrain, landscape, archaeology, geological monitoring
M5	UAV based LIDAR	5 – 200 (≤20)	Medium	Terrain, 3D site topography, complex building forms, roofs, site services (powerlines etc), penetration of vegetation

Class	Process (example equipment)	Range [m] (typical point cloud density [mm])	Typical Cost	Potential Uses
H1	Aerial LIDAR	500 – 4000 (≤50)	High	Terrain, 3D landscape topography, land usage, archaeology, penetration of vegetation
<p>Notes:</p> <p>According to the Metric Survey(12) minimum sized features that can be digitised/modelled should be around 1x to 10x the average point cloud density.</p> <p>In very broad terms typical survey cost for measurement of heritage assets (building, structure, landscape) translate as follows; low – Less than £2,000; medium £2,000 to £10,000; high above £10,000. This is for commissioning the measurement survey and not purchasing just the data.</p> <p>Point cloud density developed from digital photogrammetry depends on sensor quality, range and several photographic parameters and, therefore, the density relates to the method used for post processing images. Given this, typical densities are not given.</p>				

8.3 Level of detail

Different LoDs suggested for asset and conservation management activities are listed in

Table 8-2 to Table 8-7. These cover both 3D, and 2D graphical information including archive material. Also included is the hybrid method described in 3.1. This avoids explicit modelling of existing fabric relying instead on point cloud data to provide geometry, but using BIM objects for new fabric additions. This method can be particularly cost effective.

The different LoDs will depend on the envisaged conservation work and potential uses for the BIM environment, and this in turn will dictate the most appropriate model tolerance and survey class. In addition, the survey class will depend on the type and scale of the asset whether it is an artefact, building, bridge, landscape etc. For example, there would be little merit in using an expensive long range laser scanner to measure the inside of a room even though the model tolerances could probably be achieved.

The heritage significance based on listing, summarised in Section 7.3.3, is also likely to be an important factor in deciding the LoD. In the LoD tables, listings are also suggested for different LoDs. The reasoning is that higher significance might justify the increased cost associated with higher LoDs.

Visual examples are based on Harmondsworth Barn and The Iron Bridge datasets, and because one is a building the other a bridge slightly different options for survey classes are suggested. Images at a scale more like icons are included in these tables to help illustrate LoD. Larger and clearer versions are included in the Appendix.

Table 8-2 and Table 8-3 show the likely range of different LoDs for 3D and 2D graphical representations of LoD respectively for Harmondsworth Barn. Table 8-3 includes archive information which it is anticipated could be vast and in hard copy form. Ideally this would be scanned so that it could be held in a CDE, but more reasonably given cost constraints, digital references would be sufficient. If the English Heritage estate asset management system, see Section 6.2, is populated the information that is held could be referenced by BIM models and this would be good start to LoD 1.

All LoDs could be used in a CDE so that Level 2 BIM as shown in Figure 3-1 is achieved but this would require considerable IT infrastructure to be provided. More likely is that BIM Level 0 and 1 would be the first steps using these LoDs.

Table 8-2 Level of Detail - Harmondsworth Barn example

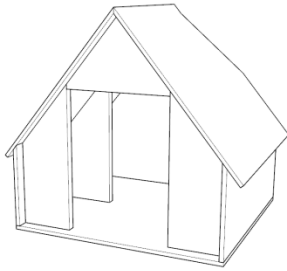
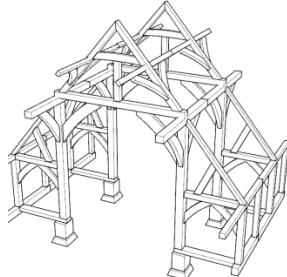
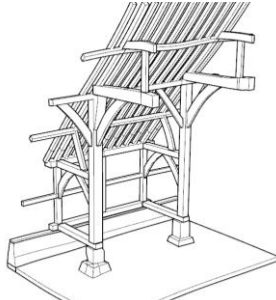
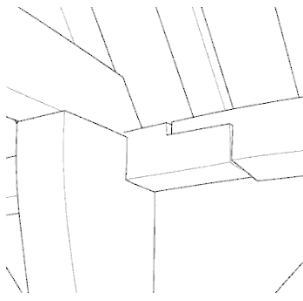
LoD	Description	Visual example (model tolerance)	Survey Class (listing grade)	Potential Uses
1	<p>A simplified representation of the overall size and arrangement</p> <p>Includes walls and floors/ceilings</p> <p>No doors or windows</p> <p>Modelled as single or multiple objects</p> <p>Information/data potentially tagged to locations and/or simple objects</p>	 <p>(Simplistic)</p>	<p>L1 L2 L3 (any)</p>	<p>Simplest way of providing spatial context to building/site</p> <p>Linking Asset management data using information tagged to locations</p>
2	<p>Primary features are represented in a simplified form</p> <p>Window and door openings</p> <p>Most objects modelled as correct category wherever possible</p> <p>Most objects modelled as individual forms of approx. correct size, shape and location</p> <p>Information/data can be attached to each part</p>	 <p>(low)</p>	<p>L1 L2 L3 M1 M3 (any)</p>	<p>Site orientation and single coordinate system for positioning</p> <p>Geometry complete enough to plan conservation projects</p> <p>Asset management data added to representative individual objects</p>
3	<p>Most building features are represented using illustrative family types or modelled-in-place elements of correct type where possible</p> <p>Windows and doors as families/components in the style of the actual objects</p>	 <p>(medium)</p>	<p>L2 L3 M1 M3 (II*,I)</p>	<p>Site orientation and single coordinate system for positioning</p> <p>Geometry complete enough to plan in detail conservation projects</p> <p>Asset management data added to representative individual objects</p> <p>Accurate Visualisation</p> <p>Clash detection</p>
4	<p>As many features as possible represented as realistically as possible</p> <p>Potentially using custom built families</p> <p>Walls potentially showing inclined and/or bowed profile</p> <p>Beams and columns showing actual shape (i.e. loaded shape)</p> <p>Connection details to be included</p>	 <p>(high)</p>	<p>M2 M3 M5 (I)</p>	<p>As LoD 3 but geometry modelling detailed enough to fabricate, fit and manufacture repairs/restoration of parts</p> <p>Geometry models good enough for 3D printing technology</p>

The suggested listing grade is very much indicative as it is appreciated that there will be many exceptions. There might be other reasons why less important buildings might require high LoD,

for instance, a complicated insertion of new structure within historic envelope. The listing grades are perhaps a better guide for recording purposes.

Table 8-3 Level of Detail, 2D information - Harmondsworth Barn example

LoD	Description	Visual example (drawing tolerance)	Survey Class (listing)	Potential Uses
0a	Archive drawings, sketches and photographs Scanned media	(unknown)	n/a (any)	May provides vital information on original construction, repairs, earlier conservation processes and where future work is to be targeted
0b	Scanned media and hand sketches	(low)	L0 (any)	Simplest way of often capturing arrangements in the field
0c	2D CAD	 (medium)	L0 L3 (any)	The simplest way of producing correctly proportioned and scalable drawings Produced by slicing through 3D point cloud data and is often an alternative to LoD 2

Table 8-4 shows LoDs and the hybrid method of modelling for both 2D and 3D representations that avoids costly modelling of the existing asset. To show that LoD is being represented with this hybrid approach an H prefix is given to the level code, for example LoD H1 is the same as LoD 1 except hybrid information is being used.

The hybrid method also overcomes the problem of using new-build BIM software such as AutoDesk’s Revit and Bentley’s MicroStation to represent historic buildings where floors and walls are not plane, and not either horizontal or vertical. Developing historic buildings and other heritage structures and sites with such idealised shapes may compromise the amount of valuable information captured by the surveys and could introduce errors where high LoD is being used; moreover; repairs and renovations do not fit an idealised geometry.

Another hybrid method is to automatically generate triangular meshes from point clouds. Depending on the survey method and goal, these meshes can vary from capturing very fine surface detail to a more simplified mesh of a large ground surface. Like point clouds these meshes cannot be directly developed into objects but, depending on their size (number of triangles in mesh), they can be read into conventional BIM software.

Table 8-4 Level of Detail, Hybrid environments - Harmondsworth Barn example

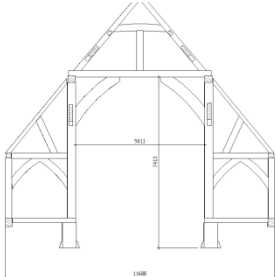



LoD	Description	Visual example (drawing/model tolerance)	Survey Class (listing)	Potential Uses
H 0c	Orthographic point cloud projections/elevations with/without CAD outlines	 (medium)	L3 M3 (any)	A rapid way of producing correctly proportioned and scalable drawings with surface detail Produced by a prescribed volume of the 3D point cloud in 2D drawing space More information than LoD 0c and an alternative to LoD 2
H 1	Avoids the effort required for even simple modelling. Ideal for tagging information to spatial locations	 (medium)	L3 M3 (any)	Linking Asset management data using information tagged to locations (red objects in example) within the point cloud Similar uses to LoD 1
H 3	Avoids the considerable effort required to CAD and create 3D objects of existing asset Includes LoD 3 for new conservation work (new tie beam added in the example) Information/data potentially tagged to locations and/or simple objects	 (medium)	L3 M3 (any)	Provides all the uses of LoD 3 for new conservation projects Existing detail and usage is LoD H 1
HM 3	Automatic meshing of point cloud to varying densities Includes LoD 3 for newly added elements as H 3. Information/data potentially tagged to locations and/or simple objects	 (medium)	L3 M3 (any)	Provides all the uses of LoD 3 for new added elements Existing detail and usage is LoD H 1 Good viewing options
HM 4	Automatic very fine meshing of point cloud to varying densities Includes LoD 4 for newly added elements. Information/data potentially tagged to locations and/or localised detailed objects	 (high)	L1 M2 M3 (any)	Provides all the uses of LoD 4 for new added elements. Extremely high level of detail allows surface detail to be represented including carving, markings, texture and structure, erosion Good viewing options

Table 8-5 and Table 8-6 show the likely range of different LoDs for 3D and 2D graphical representations of LoD respectively for The Iron Bridge, and Table 8-7 shows the hybrid method for both 2D and 3D LoD.

Table 8-5 Proposed level of Detail – The Iron Bridge example

LoD	Description	Visual example (model tolerance)	Survey Class (listing)	Potential Uses
1	<p>A simplified representation of the overall size and arrangement</p> <p>Includes position of frames and bridge deck.</p> <p>No connection details</p> <p>Modelled as single or multiple objects</p> <p>Information/data potentially tagged to locations and/or simple objects</p>	 <p>(Simplistic)</p>	<p>L1 L2 L3 (any)</p>	<p>Simplest way of providing spatial context to building/site</p> <p>Linking Asset management data using information tagged to locations</p>
2	<p>Primary features are represented in a simplified form</p> <p>Includes connections and variable width of parts.</p> <p>Most objects modelled as correct category wherever possible</p> <p>Most objects modelled as individual forms of approx. correct size, shape and location</p> <p>Information/data can be attached to each part</p>	 <p>(low)</p>	<p>L1 L2 L3 M1 M3 (any)</p>	<p>Site orientation and single coordinate system for positioning</p> <p>Geometry complete enough to plan conservation projects</p> <p>Asset management data added to representative individual objects</p>
3	<p>Most bridge features are represented using illustrative family types or modelled-in-place elements of correct type where possible</p> <p>Members and connections are families/components in the style of the actual objects</p>	 <p>(medium)</p>	<p>L2 L3 M1 M3 M4 (II*,I)</p>	<p>Site orientation and single coordinate system for positioning</p> <p>Geometry complete enough to plan in detail conservation projects</p> <p>Asset management data added to representative individual objects</p> <p>Accurate Visualisation</p> <p>Clash detection</p>
4	<p>As many features as possible represented as realistically as possible</p> <p>Potentially using custom built families</p> <p>Frame connections potentially showing bolts and wedges</p> <p>All frame and bridge parts showing actual shape.</p> <p>All connection details to be included</p>	 <p>(high)</p>	<p>M2 M3 M4 M5 (I)</p>	<p>As LoD 3 but geometry modelling detailed enough to fabricate, fit and manufacture repairs/restoration of parts</p> <p>Geometry models good enough for 3D printing technology</p>

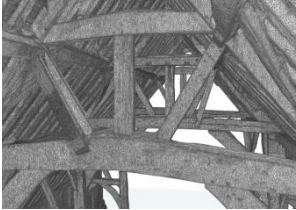
Table 8-6 Level of Detail, 2D information – The Iron Bridge example



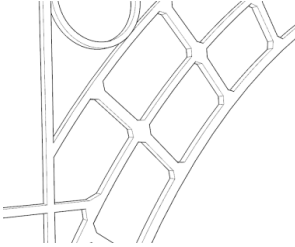
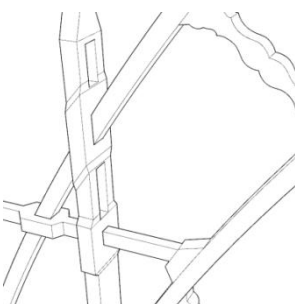
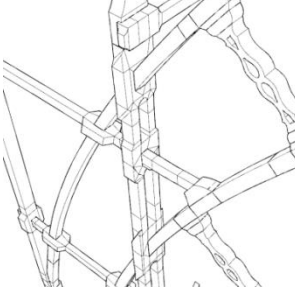
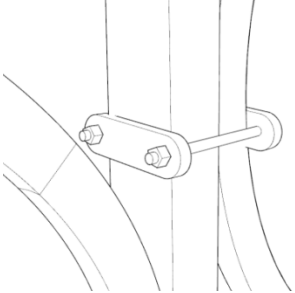

LoD	Description	Visual example (drawing tolerance)	Survey Class (listing)	Potential Uses
0a	Archive drawings, sketches and photographs Scanned media	 (unknown)	n/a (any)	May provides vital information on original construction, repairs, earlier conservation processes and where future work is to be targeted
0b	Scanned media and hand sketches	 (low)	L0 (any)	Simplest way of often capturing arrangements in the field
0c	2D CAD	 (medium)	L0 L3 M3 (any)	The simplest way of producing correctly proportioned and scalable drawings Production by slicing through 3D point cloud data is often an alternative to LoD 2

Table 8-7 Level of Detail, Hybrid environments – The Iron Bridge example

LoD	Description	Visual example (drawing/model tolerance)	Survey Class (listing)	Potential Uses
H 0c	Orthographic point cloud projections/elevations with/without CAD outlines	 (medium)	L3 M3 (any)	A rapid way of producing correctly proportioned and scalable drawings with surface detail Produced by a prescribed volume of the 3D point cloud in 2D drawing space More information than LoD 0c and an alternative to LoD 2
H 1	Avoids the effort required for even simple modelling. Ideal for tagging information to spatial locations	 (medium)	L3 M2 M3 (any)	Linking Asset management data using information tagged (red objects in example) to locations within the point cloud Similar uses to LoD 1

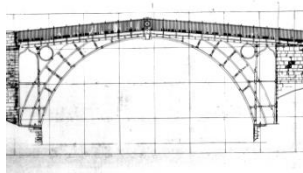
LoD	Description	Visual example (drawing/model tolerance)	Survey Class (listing)	Potential Uses
H 3	<p>Avoids the considerable effort required to CAD and create 3D objects of existing asset</p> <p>Includes LoD 3 for new conservation work (new strengthening plate added in the example)</p> <p>Information/data potentially tagged to locations and/or simple objects</p>	 <p>(medium)</p>	L3 M2 M3 (any)	<p>Provides all the uses of LoD 3 for new conservation projects</p> <p>Existing detail and usage is LoD H 1</p>

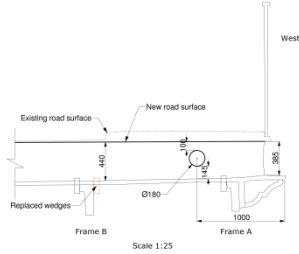
9. HERITAGE – LEVEL OF INFORMATION

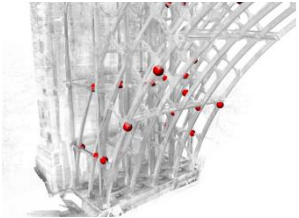
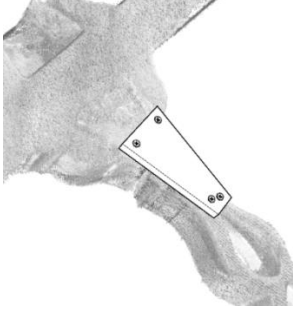
Establishing the level of information required for different sites and conservation activities depends on many factors, and it is difficult to see how these can align in a standardised way similar to LoD and the resulting LoMD. This is an area that requires further development.

However, COTAC(13) have considered how conservation should influence BIM when applied to heritage sites, and elements of this work begin to set out the types of information required to be incorporated into BIM, and perhaps LoD for different LoMD. The aim has been to determine the related factors regarding historic significance, functions and surrounding influences on historic/traditionally built buildings and their neighbourhoods. This is perhaps the first stage in attempting to provide LoI that maps to the emerging HBIM framework cyclic diagram produced by COTAC and shown in Figure 6-1. The updated diagram reproduced from Part 2 of the COTAC BIM4C integrating HBIM framework reports is shown in Figure 9-1.

COTAC suggests an approach involving three Key Steps and LoI would accumulate through these stages.

1. Definition
2. Data Collection, Diagnosis and Evaluation. Any conservation intervention would be site specific.
3. Intervention Strategy

Once the relevant definition of the building or structure’s status, significance, value and quality has been established, it should be possible to set about collecting data, both graphical and non-graphical, to assist in judging the relative effectiveness of conservation activities.

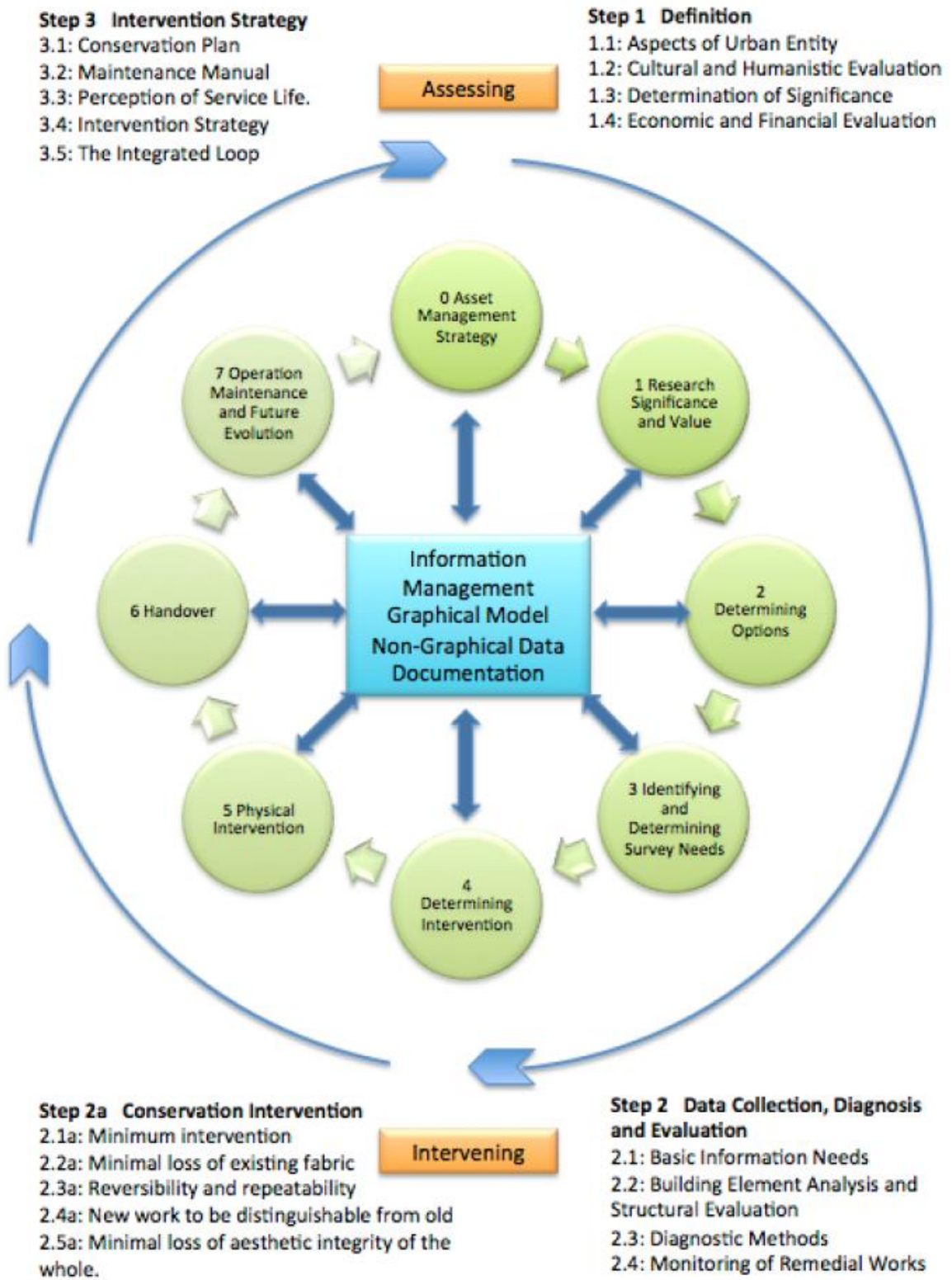

Figure 9-1 BIM LoI conservation influencing factors

10. BIM DATASETS

BIM applied to heritage sites will involve many dataset types, both graphical and non-graphic, different information recording and reporting processes, and various classification systems with data held within a CDE. The principal activities involved that are likely to be important for successful implementation of BIM for the conservation of heritage assets are described in the following sections, using examples developed from the datasets of the two sites.

The development of BIM datasets with functioning examples have been made available through a web domain purchased as part of this work. The URL is <http://www.bim4h.org>. This domain has been used solely for this project. The domain is accessible to anybody, but as navigation links are not included on the homepage, access to project data can only be made using URLs provided in this report. This provides a basic level of access security.

Where new datasets have been obtained as part of this work, for instance Revit models, these have been issued using a USB memory stick.

10.1 Positioning

BS 1192(5) suggests a statement or diagram should be produced that relates the project space to a named global geospatial system in three dimensions (decimal degrees latitude, longitude and elevation in metres) and a plan orientation (decimal degrees clockwise rotation from north). It also suggests that alternatively reference can be made to a standard named projection such as the UK Ordnance Survey grid. An extension of this for BIM, especially for large estates, is to use a GIS environment to access data. This enables geospatial searching and positional relationships to be easily carried out. Ideally this would be linked to the asset management system in a similar way to the AIM and assessment management system BIM relationship shown in Figure 5-1.

ArcGIS Online(14) has been used to position the two sites on a UK map and to provide high-level data such as name, location, type of asset, and also link to their respective BIM environments. These links point to the BIM model in the cloud (cloud computing) using Autodesk 360(14). The screenshots in Figure 10-1 show an example GIS environment setup to show the possibilities for these projects. The example GIS can be viewed at

<https://rambollglobal.maps.arcgis.com/apps/MapTools/index.html?appid=67df1c50006243de9a69a3e0c777fa6c>.



Figure 10-1 Screen shots from GIS GUI showing site positions

11. HARMONDSWORTH BARN

11.1 General

The GIS application in Figure 11-1 shows the information available for the Harmondsworth Barn site, including links to various resources such as encyclopaedia websites, BIM datasets, surveys and imagery.

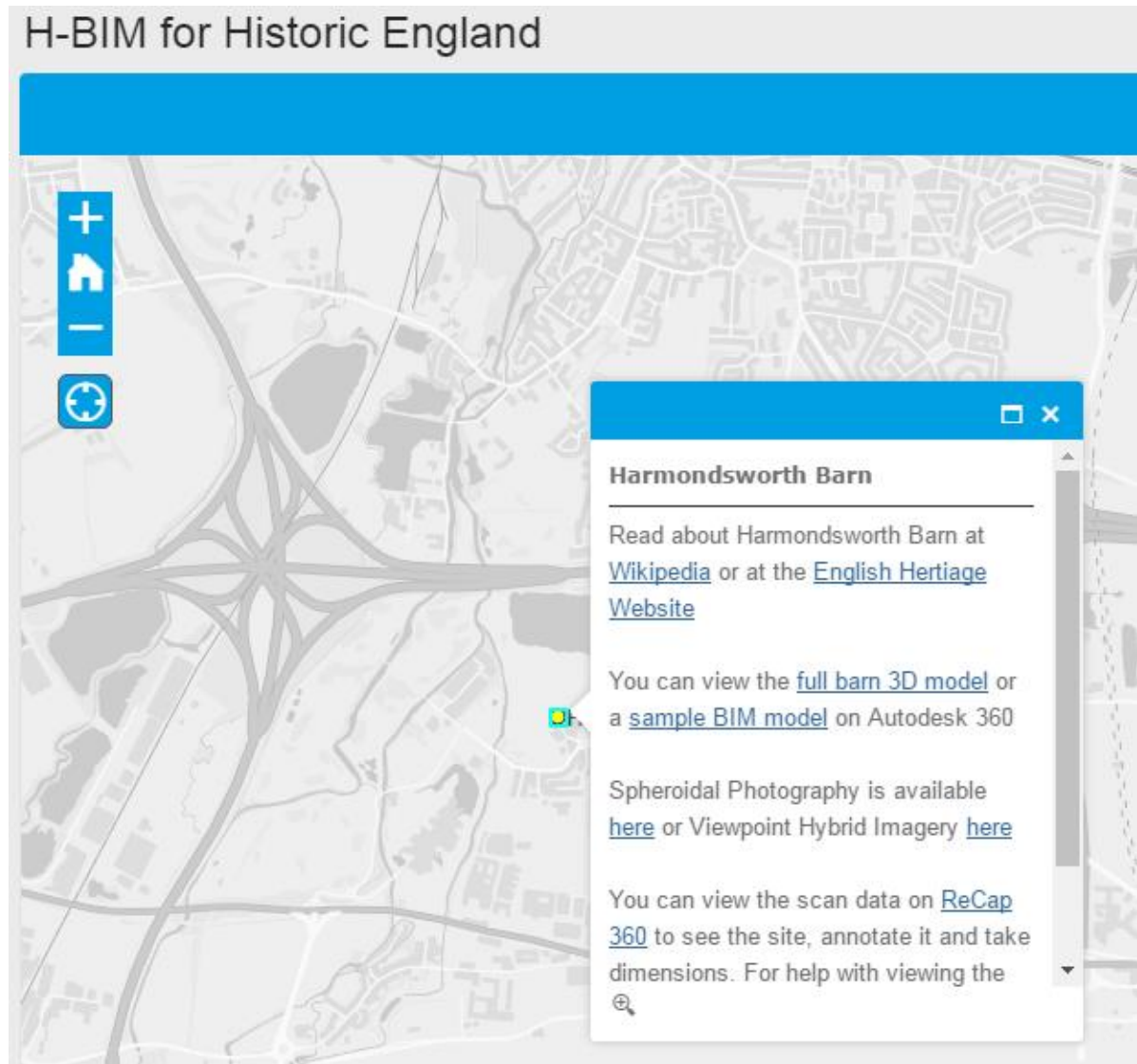

Figure 11-1 GIS for Harmondsworth Barn site

11.2 Modelling and LoD

A simplified 3D model of Harmondsworth Barn was developed by CyArk in 2014 using Autodesk 3DS Max. This model was read into Rhinoceros(16) and uploaded to AutoDesk 360(14) to demonstrate the navigation from GIS to 3D model. Figure 11-2 below shows screenshots of the model, first in a complete form, then with the frame mass selected and finally with a developed horizontal section being applied. This model is available at <http://a360.co/1TZP9BT>.

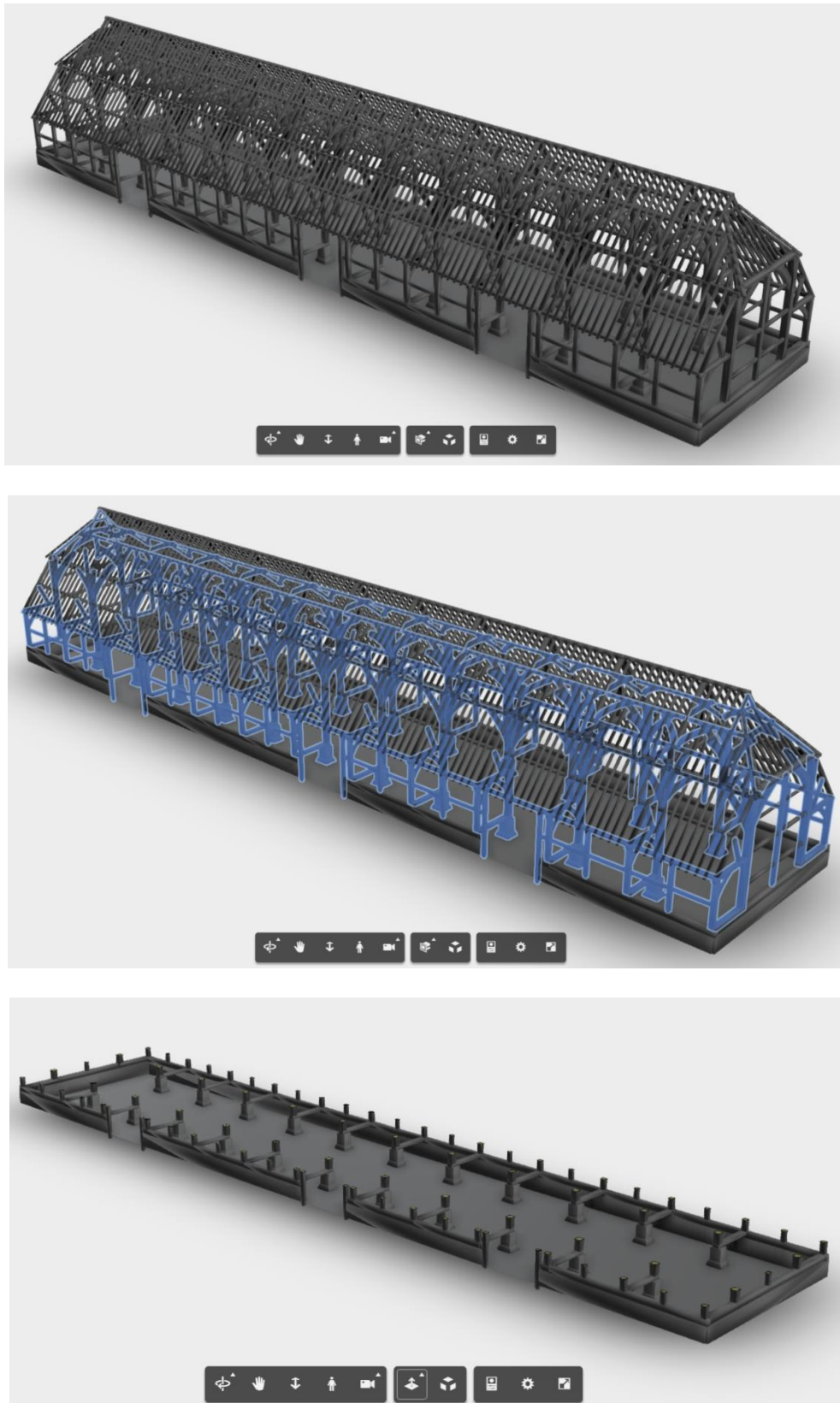

Figure 11-2 Images of the Harmondsworth Barn 3D model

Whilst the CyArk model is useful to demonstrate the navigation process, it is essentially just a few masses and is therefore not optimal for accessing BIM data. To achieve this goal a sample model of 2 bays was created using Autodesk Revit 2016(16). This model was developed to LoD 2 with representative geometry of each major part of the Barn structure as shown in Figure 11-3. This model is available at <http://a360.co/2fiBdqj>.

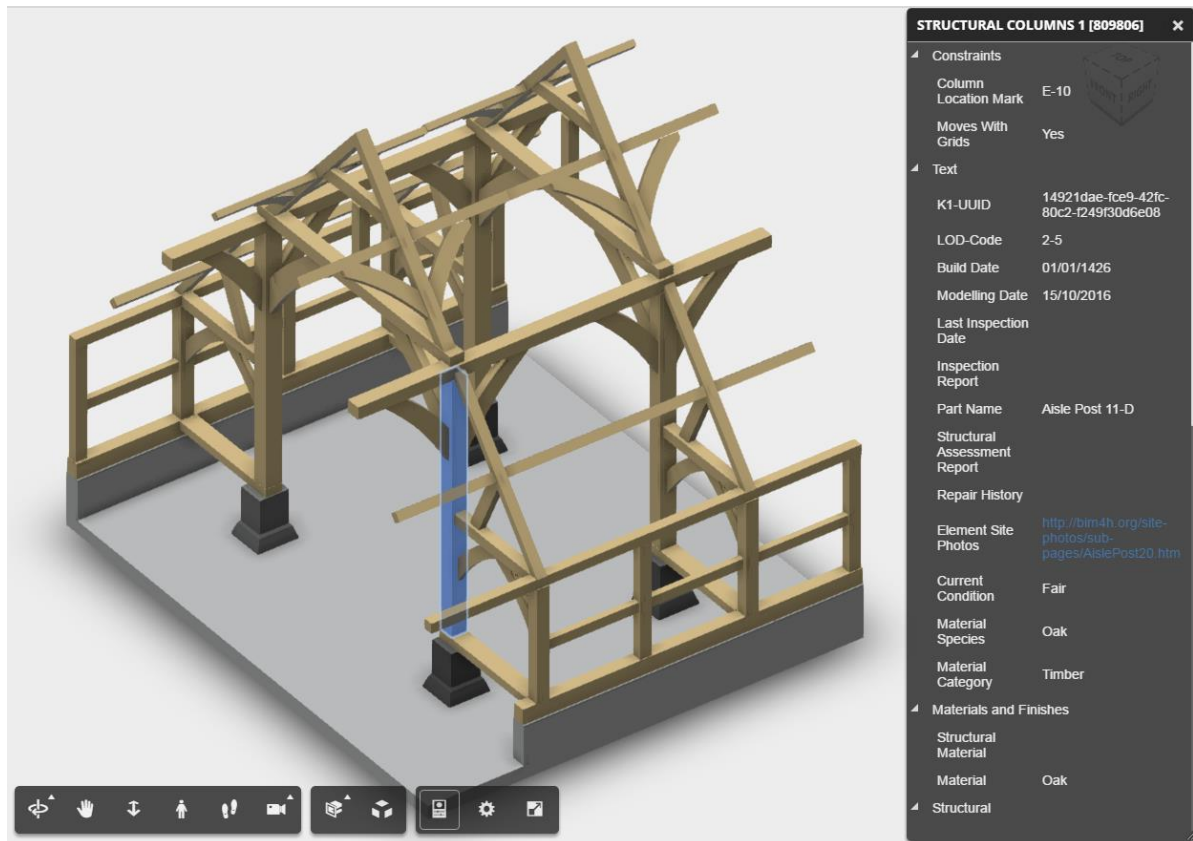

Figure 11-3 Sample LoD 2 BIM model

This model also contains sample metadata for several elements in the model as well as project specific metadata. It is an example of BIM having lower LoD but fairly high LoI which is likely to be a common aspect of BIM for heritage. A summary of the model data which includes URLs to information and resources is provided in Table 11-1. An example of the element data is provided in Table 11-2.

Table 11-1 Example Model Data

Item	Data
Asset ID	202847
Latitude	51.489671
Longitude	-0.479928
Model Coordinate system	Offset of OSGB36 by x -505600 y -177800 z 0
Project or Asset Manager	Paul.Bryan@HistoricEngland.org.uk
Modelled by	daniel.niziolek@ramboll.co.uk
English Heritage Website	http://www.english-heritage.org.uk/visit/places/harmondsworth-barn/
Historic England Website	https://historicengland.org.uk/listing/the-list/list-entry/1194332
Wikipedia	https://en.wikipedia.org/wiki/Harmondsworth_Great_Barn
Recap 360	https://recap360.autodesk.com/scanviewer/82597541b269458ea5fee5857885f5ea
Spheroidal Photography	http://bim4h.org/HarmondsworthPano/
All Site Photos	http://bim4h.org/site-photos/

Table 11-2 Example Element Data

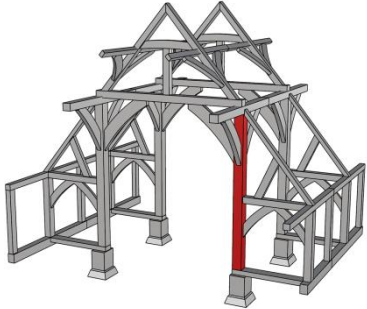
Item	Data	Image
UUID	14921dae-fce9-42fc-80c2-f249f30d6e08	
Part Name	Aisle Post 11-D	
LOD Code	2-5	
Material	Timber	
Species	Oak	
Date installed	01/01/1426	
Inspection report		
Structural Assessment Report		
Last Inspection Date	03/04/2016	
Current Condition	Fair	
Repair history		
Site Photos	http://bim4h.org/site-photos/sub-pages/AislePost20.htm	
Modelling date	15/10/2016	

A test model was produced using ClearEdge Edgewise(18), an application that can semi-automatically extract geometry such as beams and columns from the point cloud. The software has built-in libraries of standard steel, concrete and timber members, but this can be added to with custom sizes. The resulting model as seen in Figure 11-4, can then be exported into Autodesk Revit(16), with each item being a native family object. The Edgewise generated Revit model can be accessed at <http://a360.co/2jfqyuH>.

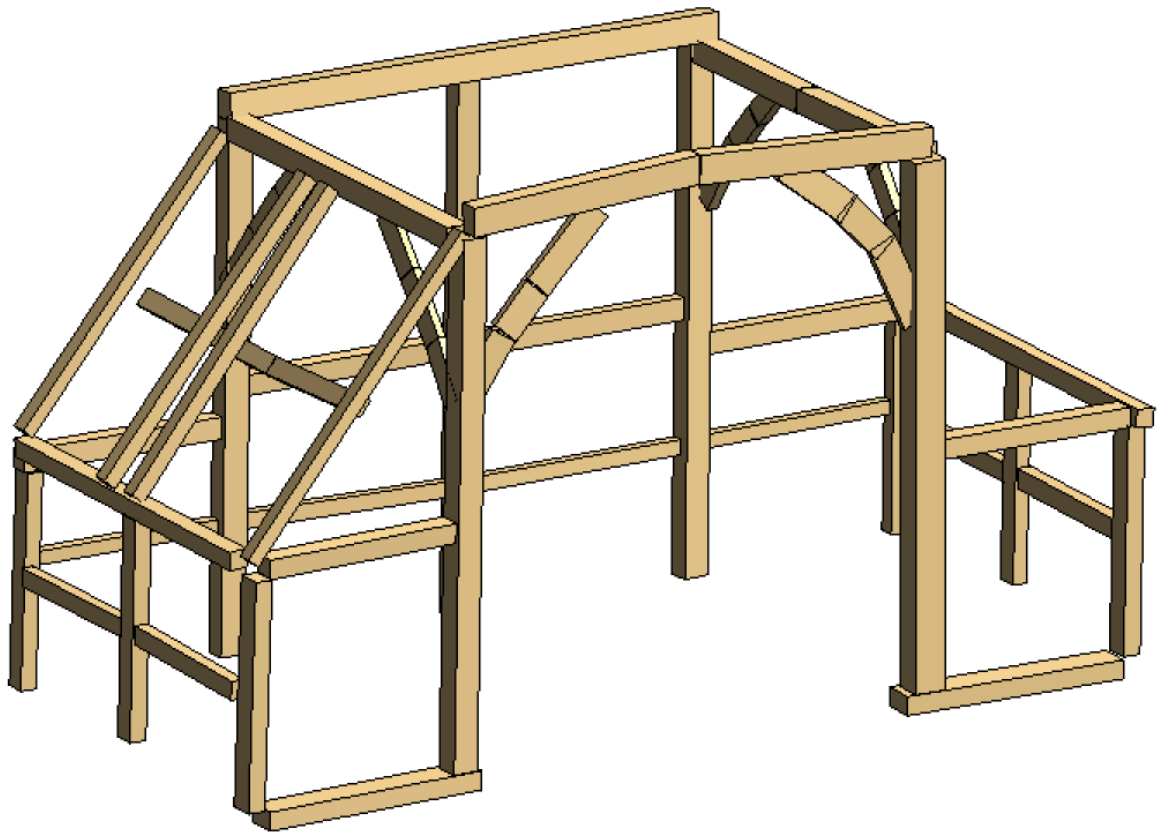
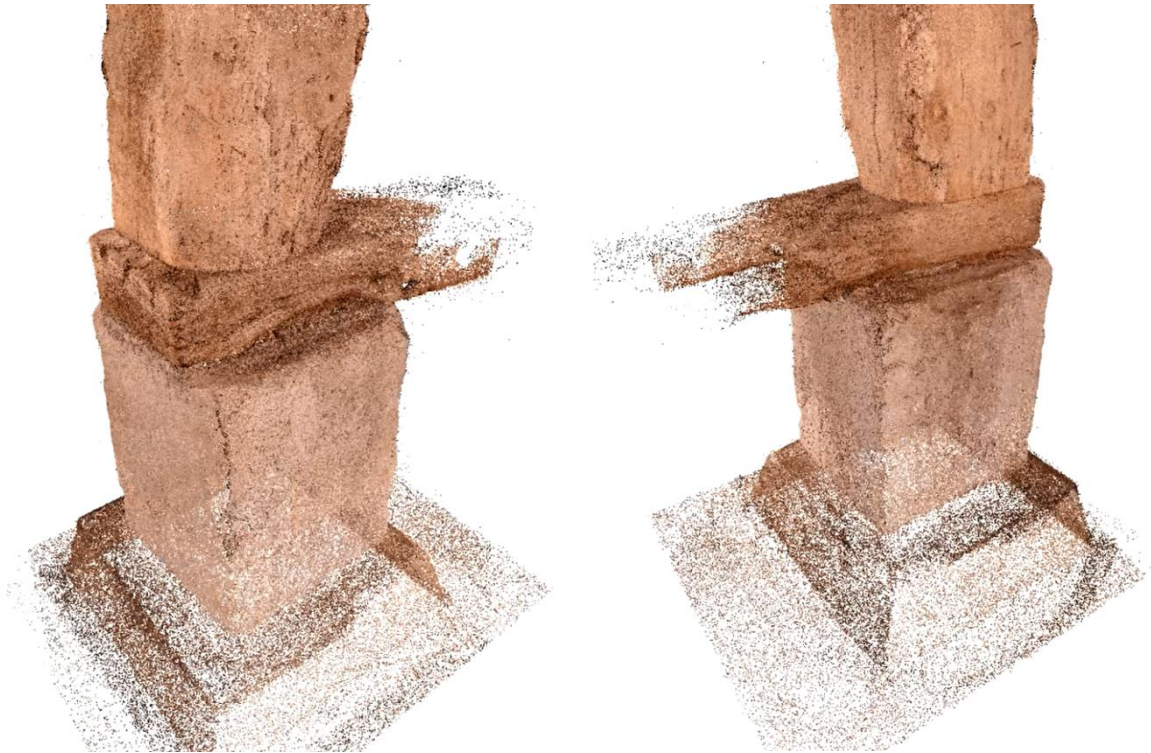
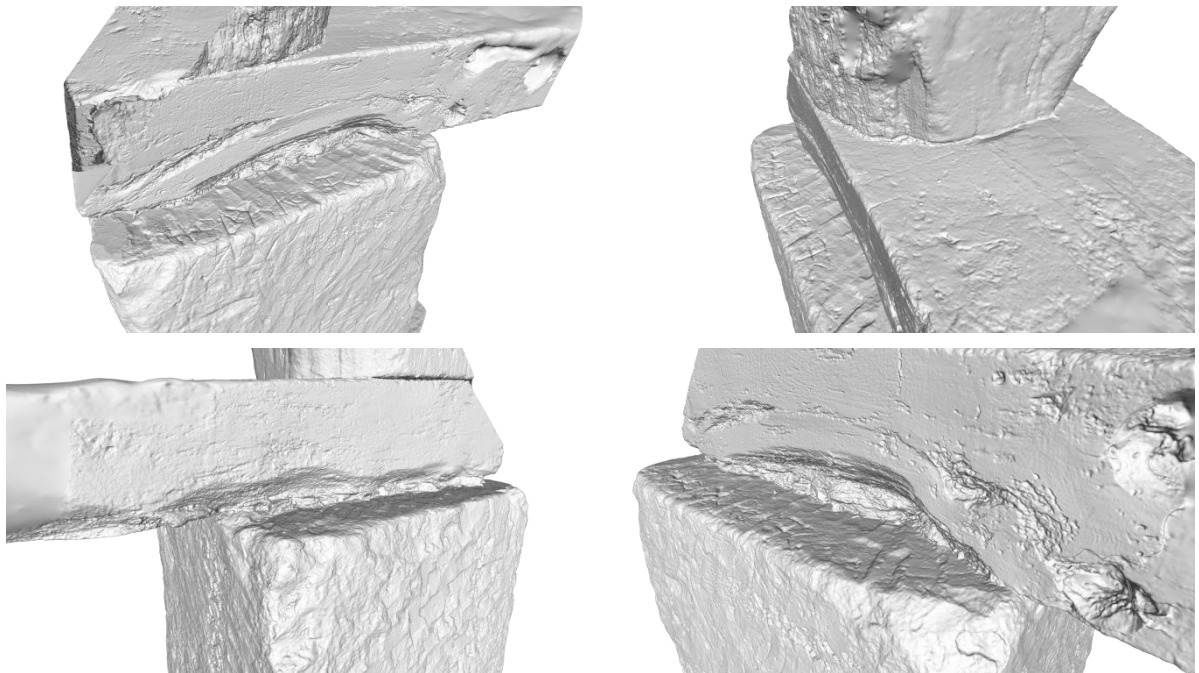

Figure 11-4 Edgewise model with and without the point cloud

Another modelling technique that has been tested was to use the latest photogrammetry software packages, Agisoft PhotoScan(19) and Autodesk ReCap Photo to 3D(20). The two models produced at LoD HM 4 are shown in Figure 11-5.



Point cloud from Agisoft PhotoScan



Mesh produced using AutoDesk ReCap

Figure 11-5 Agisoft and ReCap models

Figure 11-6 shows the same model viewed with AutoDesk ReMake(21) where mesh and photography are combined.



Figure 11-6 Model produced by ReCap and viewed by AutoDesk ReMake

11.3 360 degree imagery

360 degree panoramic imagery has been used as a way to navigate the Harmondsworth Barn site and could be used to carry out simple virtual inspections. The tool is based upon an open-source html 5 viewer called Pannellum(23), supplemented with a set of simple html navigation pages such as those seen in Figure 11-7. These 360 degree photos are available at <http://bim4h.org/HarmondsworthPano/>.

This method of viewing the site is providing information and not geometry and so is not associated with LoD.

Harmondsworth Great Barn

[Low Level](#) [High Level](#)

Externals:

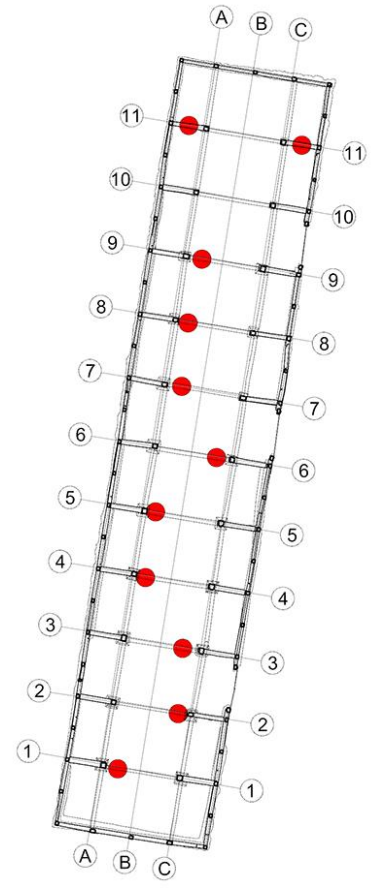
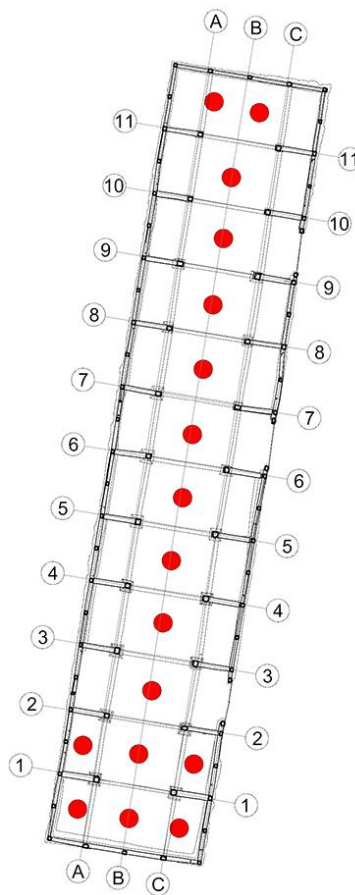

External

Low level

High level

Figure 11-7 360 degree image navigation pages at Harmondsworth Barn

The 360 degree photos were supplied by HE, and were generated using the nctech iSTAR camera system(22). These were post-processed in Adobe Photoshop(23) to improve tone, colour balance and contrast, as well as resize and optimally compress the photos for web hosting. Examples of these 360 degree photos are shown in Figure 11-8.



External 360 degree views



Internal low level 360 degree views



Internal high level 360 degree views

Figure 11-8 Example 360 degree photos of Harmondsworth Barn

360 degree imagery can be generated from the scan data and viewed online in a web browser. Ramboll used the point cloud data provided by HE to demonstrate how this could be used on heritage projects. Autodesk ReCap 360 Pro(20), which automatically generates each view upon import was used for this demonstration. Once in ReCap the data can be uploaded to Autodesk 360(14) so that it can be viewed and shared from a modern web browser, with no plugins or other expensive software needed. Users of the web based system can simply select a scan and then navigate the 360 degree view, as seen in Figure 11-9. It is also possible to add notes and take dimensions that can be seen with other users. The Real View data is available at <https://recap360.autodesk.com/scanviewer/e090cd55616d47e7a7abbc07f5841883> but Autodesk requires that the data be shared with specific Autodesk accounts. To request access please email pointcloud@ramboll.co.uk with the Autodesk account name requiring access.

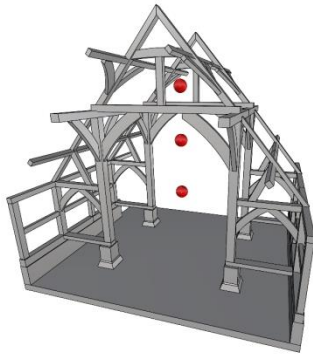

Figure 11-9 Screenshots of the ReCap 360 Real View data

One of the problems with BIM and 3D modelling in general is accessibility to those who are less technical, such as an artisan that might be working on a heritage project. Ramboll thought that a simple website featuring 360 degree images of the model might be a quick and simple way to allow these people to interact with the BIM model. So an internal plugin has been developed that uses Rhinoceros 5(16) to generate 360 degree images and videos. The tool can use any model data within Rhino so it can display CAD geometry, point clouds, meshes or any combination of these. The images in Figure 11-10 show this tool displaying the pre and post conservation points clouds, a hybrid model with post conservation point cloud and model. This tool is available at <http://bim4h.org/hybrid-panos/>.

RAMBOLL HBIM Hybrid Models

- Pre Conservation (2013)
- Post Conservation (2015)
- Hybrid Model inc. post conservation
- Post Conservation compared to 20 min Revo



© Ramboll UK Limited. Last Modified December 2016



Figure 11-10 Images of the 360 imagery of Harmondsworth Barn Hybrid Models

11.4 Monitoring and comparisons

Ramboll carried out a survey of the barn using a relatively new handheld scanner, the GeoSLAM ZEB-REVO. The instrument works similar to a laser scanner except it also determines the relative position of the device using sensors and a proprietary Simultaneous Localisation and Mapping (SLAM) algorithm, similar to those being used by autonomous vehicles. Using all of the data collected on site the SLAM algorithm can calculate the position of each point within 3D space in a single coordinate system.

The data produced from the REVO has been compared to existing datasets to help determine if this kind of data would be useful for heritage applications. It was decided that the baseline dataset for the comparisons would be the Post Conservation scans from 2015. The first comparison carried out was comparing the baseline to the pre conservation data from 2013, as seen in Figure 11-11. The results show that during this time period not much has changed with the overall structure as more than 80% of the points are within 20mm.

The results of this comparison did show up one significant difference as seen in red in Figure 11-12. The braces at high level between the Tie Beam and Principal Rafter were removed at some point between 2013 and 2015.

Min	Max
0	0.008
0.008	0.0123
0.0123	0.0177
0.0177	0.0265
0.0265	0.05
0.05	0.1
0.1	+

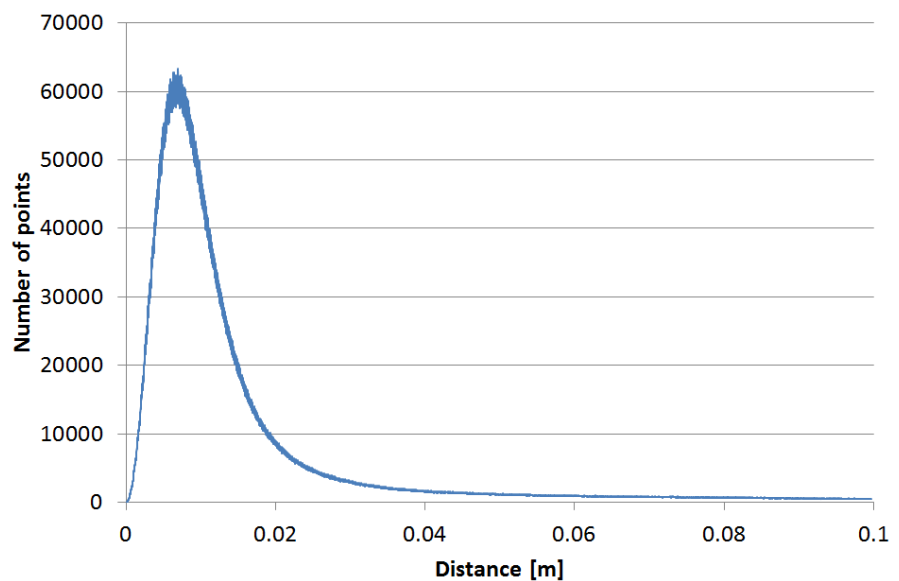
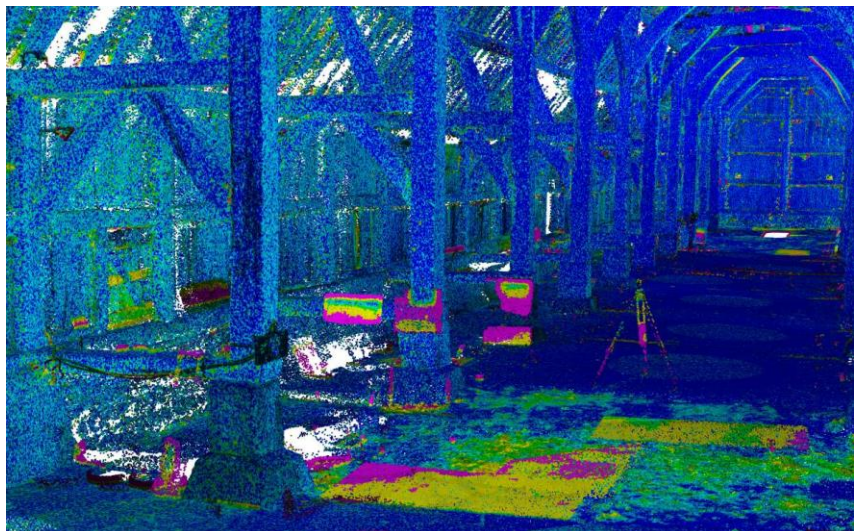

Figure 11-11 Baseline compared to Pre conservation (2013)

Comparing point clouds in these two figures illustrates two different usages. Figure 11-11 shows small differences as would be expected for monitoring. Figure 11-12 is rescaled to show large differences and useful to quickly establish whether parts are missing or new parts have been introduced.

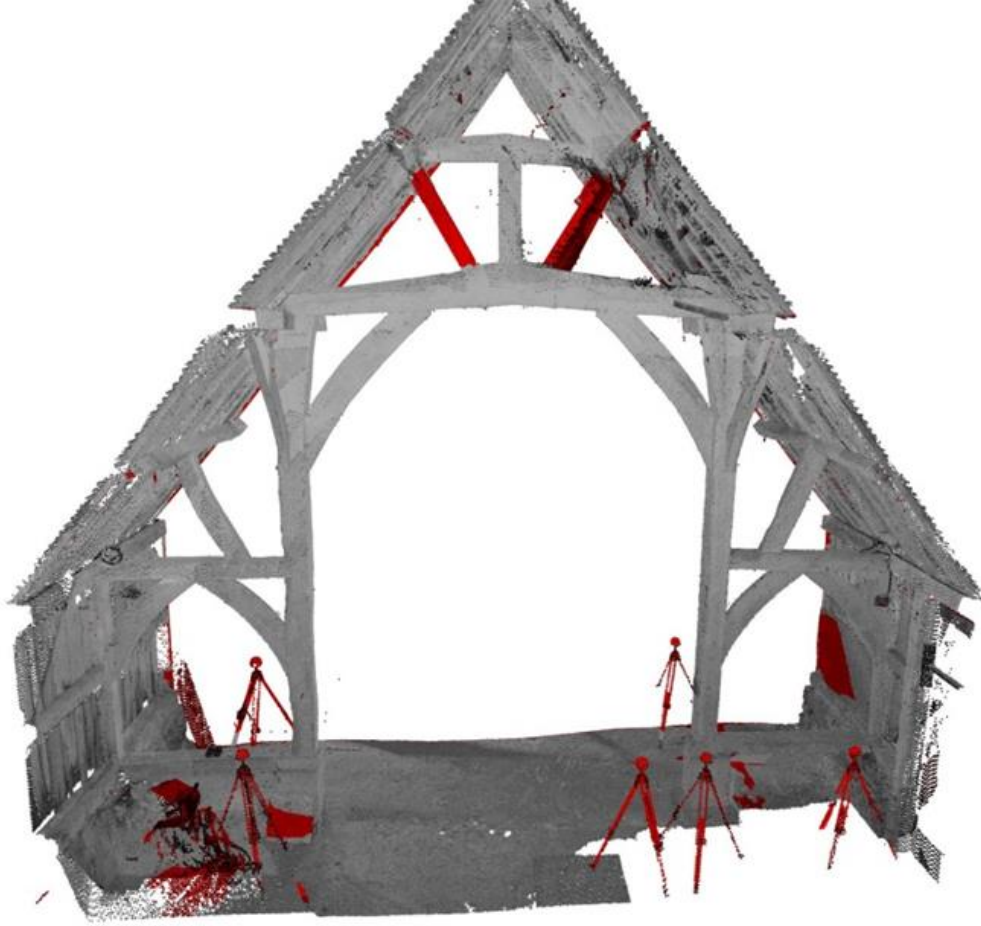

Figure 11-12 Large differences between 2013 and baseline

The next comparison was to look at the photogrammetry data of the barn exterior to the baseline. The results of this analysis, as shown in Figure 11-13 show a slightly larger difference, with approximately 60% of the points being within 20mm.

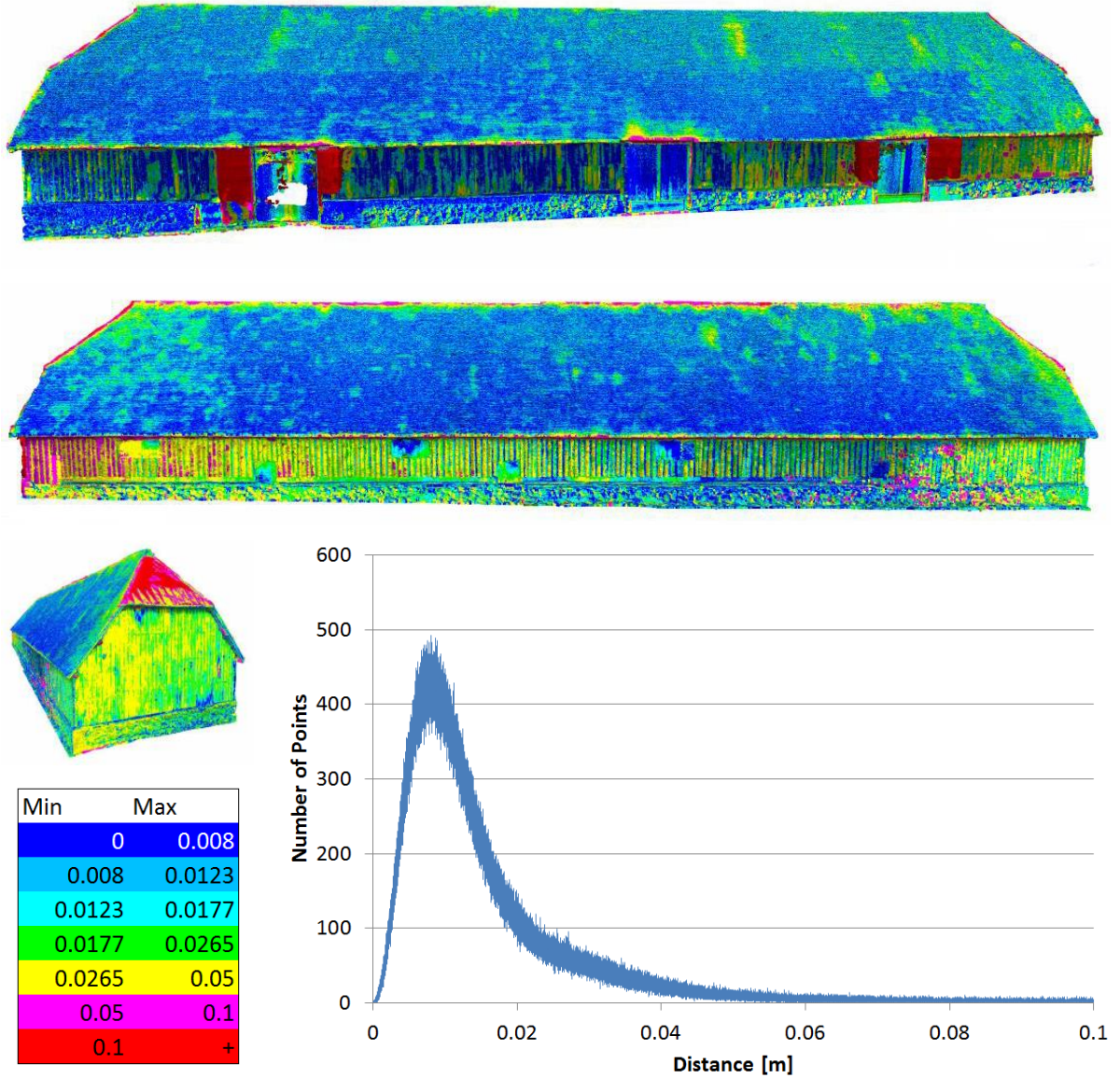

Figure 11-13 Baseline to external photogrammetry

11.5 Handheld scanning dataset

Several surveys using a GeoSLAM ZEB-REVO were carried out as part of an extension to this project to allow point clouds obtained by a handheld scanner compare with the conventional tripod mounted scanner and baseline survey. Amongst several surveys, a fast walking survey covering the interior space in 2 minutes and slow survey completed in 20 minutes were carried out. These datasets were then used in several comparisons with other datasets.

The paths taken during both the 2 and 20 minute REVO surveys are shown in Figure 11-14. The colours along these paths generated by the GeoSLAM software indicate how accurate the measurements are. No information has been provided on the accuracy calculation but blue is best, and red worst.

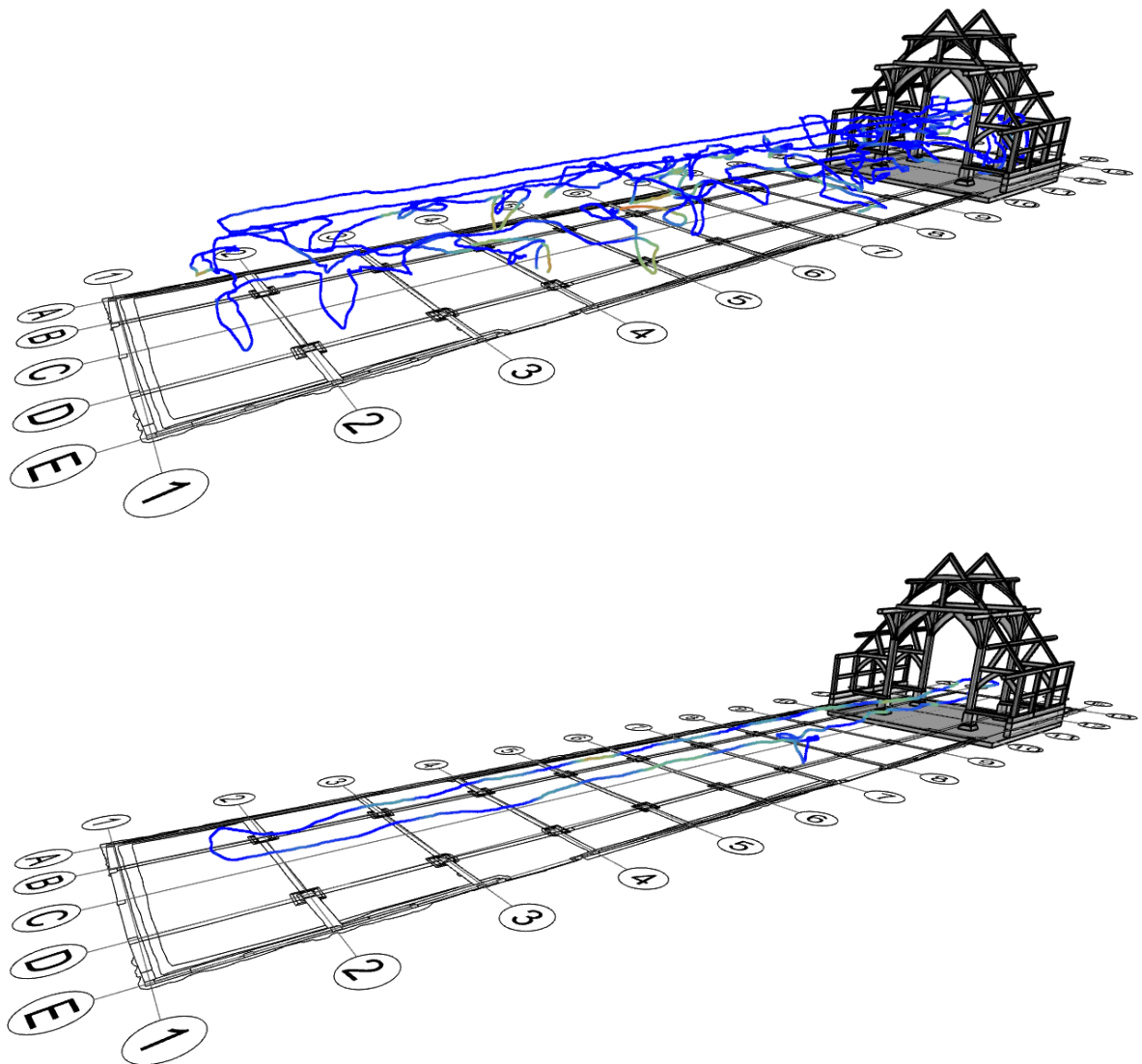

Figure 11-14 REVO Trajectories, top: 20 minute survey, bottom: 2 minute survey

The first set of comparisons with the handheld datasets was the baseline to the 20 minute and the 2 minute REVO survey. Comparisons with these two sets are shown in Figure 11-15 and Figure 11-16 respectively.

Min	Max
0	0.008
0.008	0.0123
0.0123	0.0177
0.0177	0.0265
0.0265	0.05
0.05	0.1
0.1	+

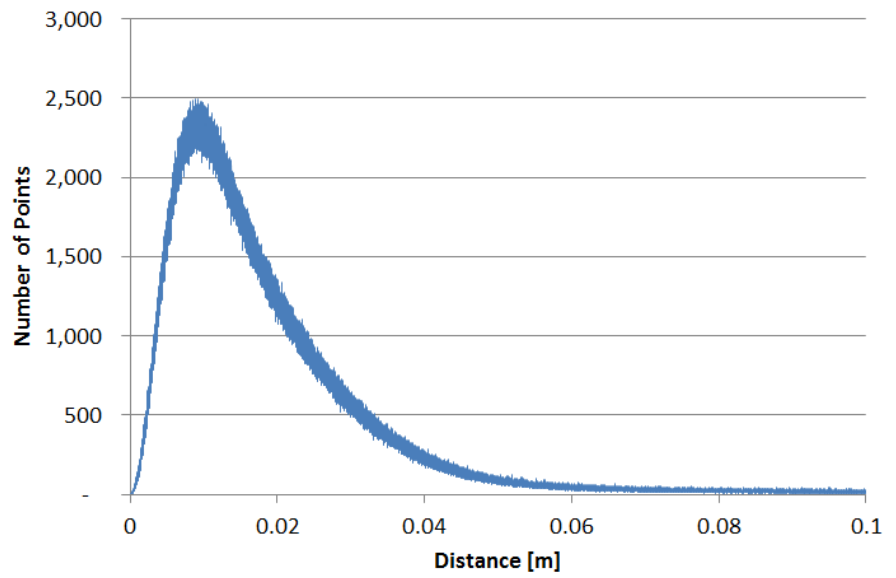
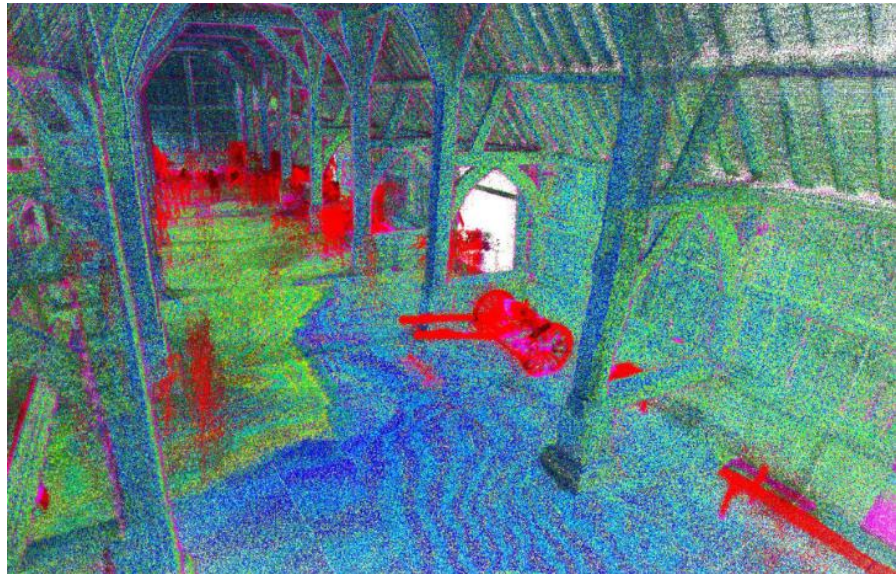

Figure 11-15 20 minute REVO survey to baseline

Min	Max
0	0.008
0.008	0.0123
0.0123	0.0177
0.0177	0.0265
0.0265	0.05
0.05	0.1
0.1	+

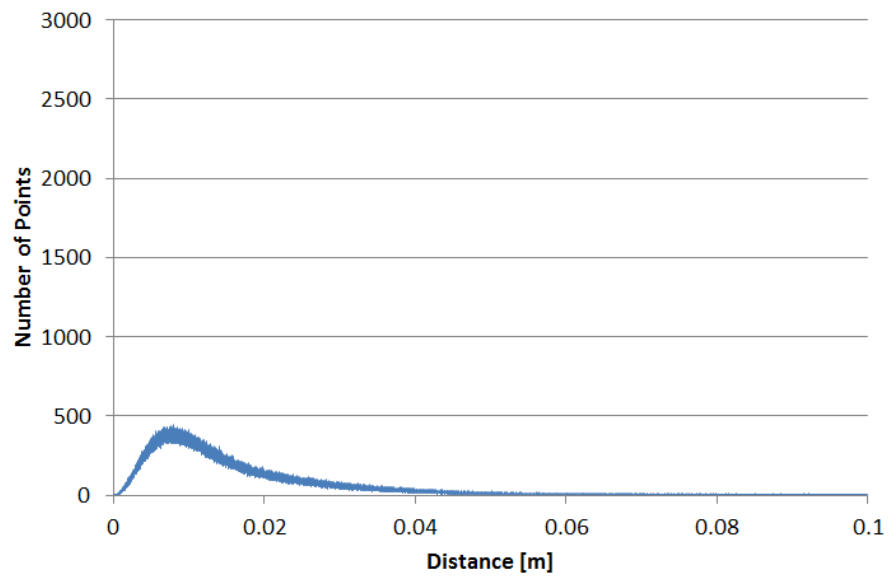
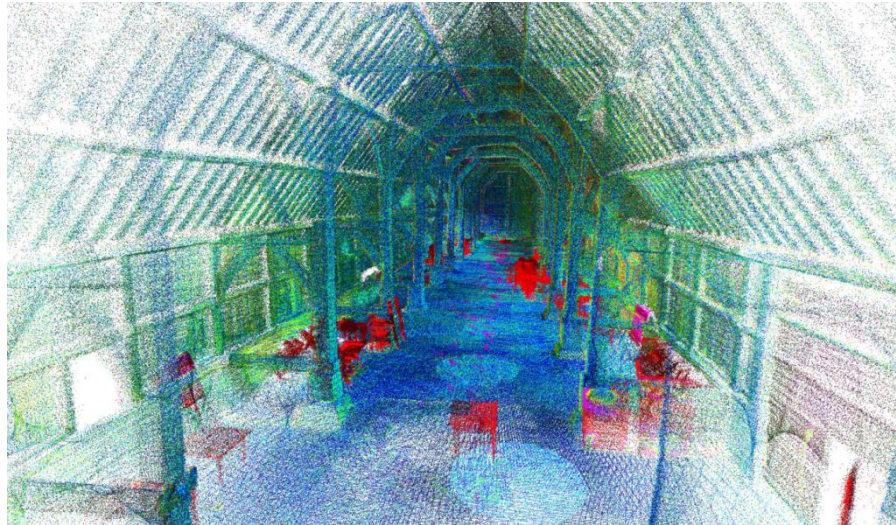

Figure 11-16 2 minute REVO survey to baseline

The comparison of results in these two figures show a very similar difference to the baseline survey, with approximately 50% of the points within 20mm and 80% within 40mm. The biggest difference between the 20 and 2 minute REVO surveys is in their coverage. This can be seen in the sections depicted in Figure 11-17 and the 3D views in Figure 11-18. The baseline survey has 1,036,200,000 points, the 20 minute REVO survey has 49,800,000 points and the 2 minute REVO survey has 6,700,000 points.

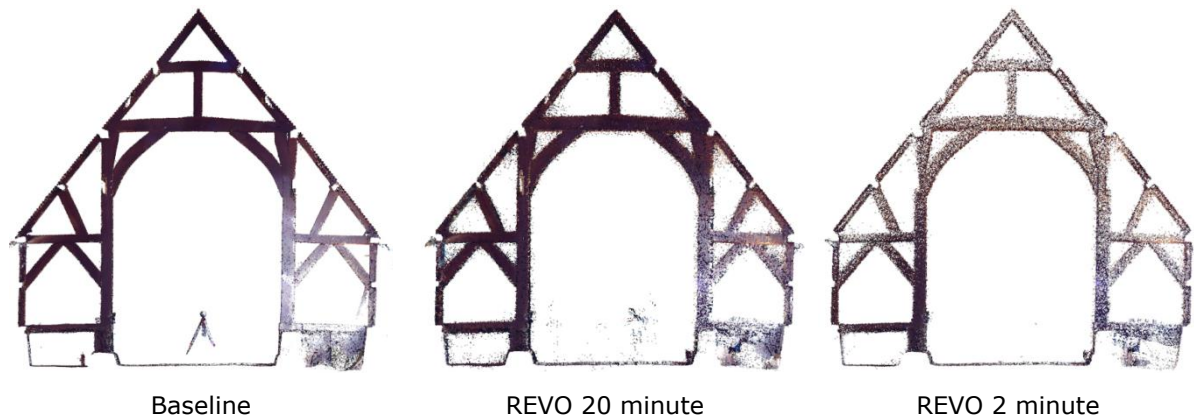

Figure 11-17 Section through baseline, 20 and 2 minute surveys



Figure 11-18 3D view of 20 minute REVO (left) and 2 minute REVO (right)

The REVO surveys were also looked at to see if 3D models could be generated from them and what LoD could realistically be achieved. The results of this activity, shown in Figure 11-19 confirm that models can be created from the 20 minute REVO data to LoD 2. Whilst the 2 minute REVO survey wasn't used in this test, due to the reduced point density it is expected that a maximum of LoD 1 could be achieved. The test REVO model can be accessed at <http://a360.co/2dXynal>.

The data generated by the REVO has no colour or intensity values unlike tripod based point cloud data. This is problematic for activities such as 3D modelling because it makes seeing features in the data much more difficult. Ramboll explored various methods of using the data as part of this project in various software packages. Autodesk's Revit(16) for example has several alternative shading options that can be used, as seen in Figure 11-20. The most useful being "Normals", which displays points with different colour based on global directions, so for examples two adjacent walls and the floor would get different colours.

Another option explored is to colourise the REVO point cloud. To do this Ramboll used a feature of CloudCompare(24) that colours each point in the REVO dataset as per the closest point to in the post conservation data. Then, using the RGB values that CloudCompare calculated, Ramboll calculated the relative luminance of each point to create grayscale intensity values as seen in Figure 11-21. It is recognised however that this process would not be achievable on most projects using a REVO scanner as tripod based scan data wouldn't normally also exist.

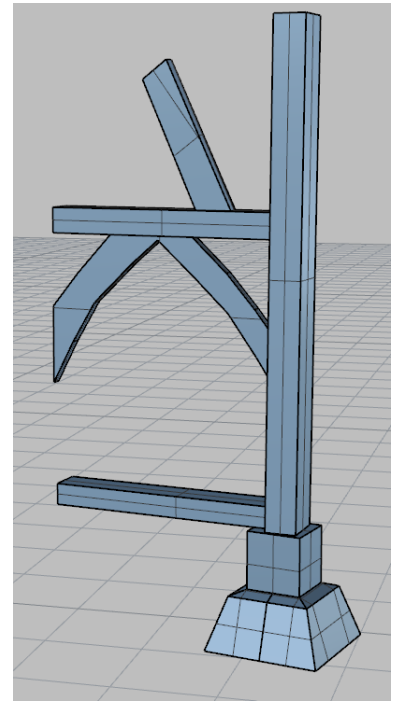
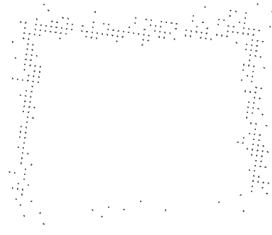
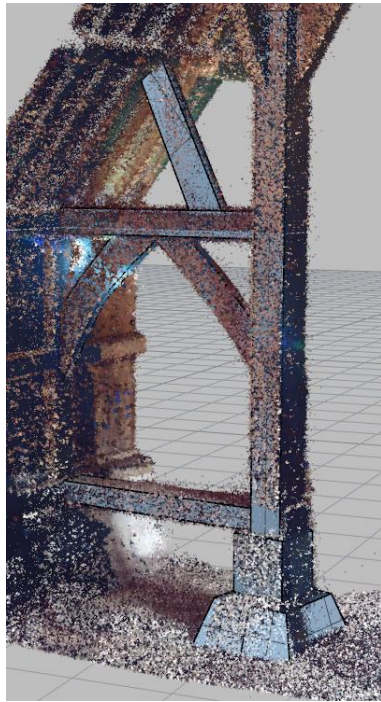
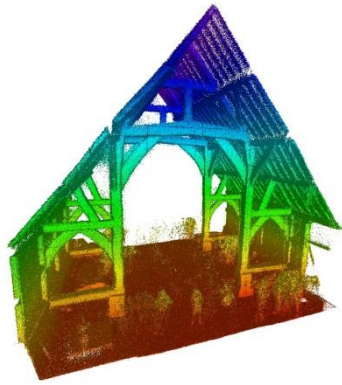
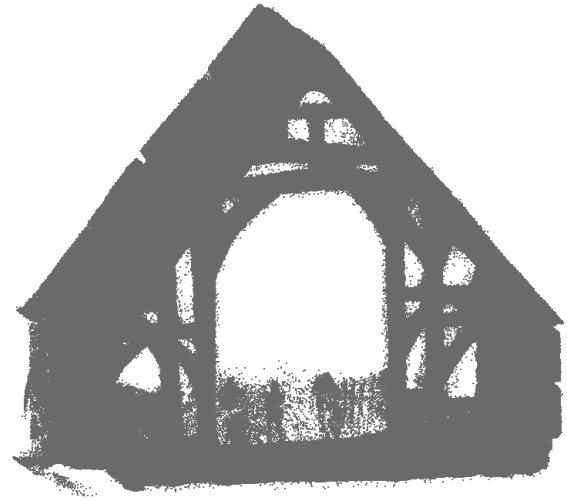

Figure 11-19 Views of the 3D model created from the 20 minute REVO survey



ReCap 360 Pro – elevation shading



Revit 2017 – default RGB shading

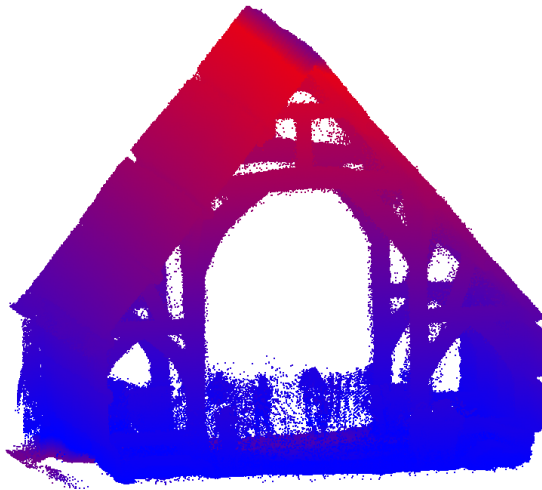

Revit 2017 – elevation shading

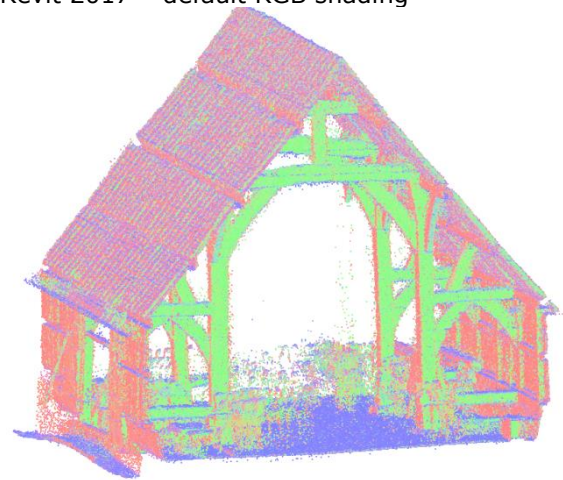

Revit 2017 – Normals shading

Figure 11-20 REVO point cloud shading

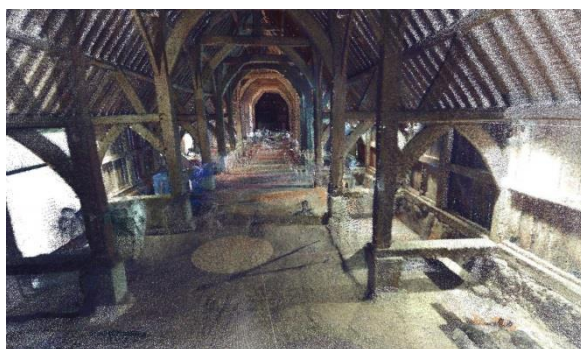

RGB colour

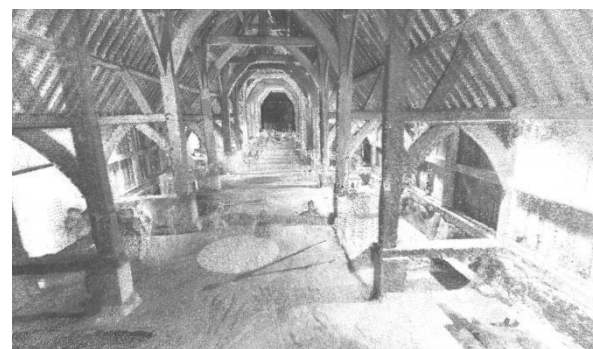

Grayscale "intensity" from RGB

Figure 11-21 REVO data with RGB and grayscale colour from post conservation data

12. THE IRON BRIDGE

12.1 General

The GIS application in Figure 12-1 shows the information available for the Iron Bridge site, including links to various resources such as encyclopaedia websites, BIM datasets, surveys and imagery.

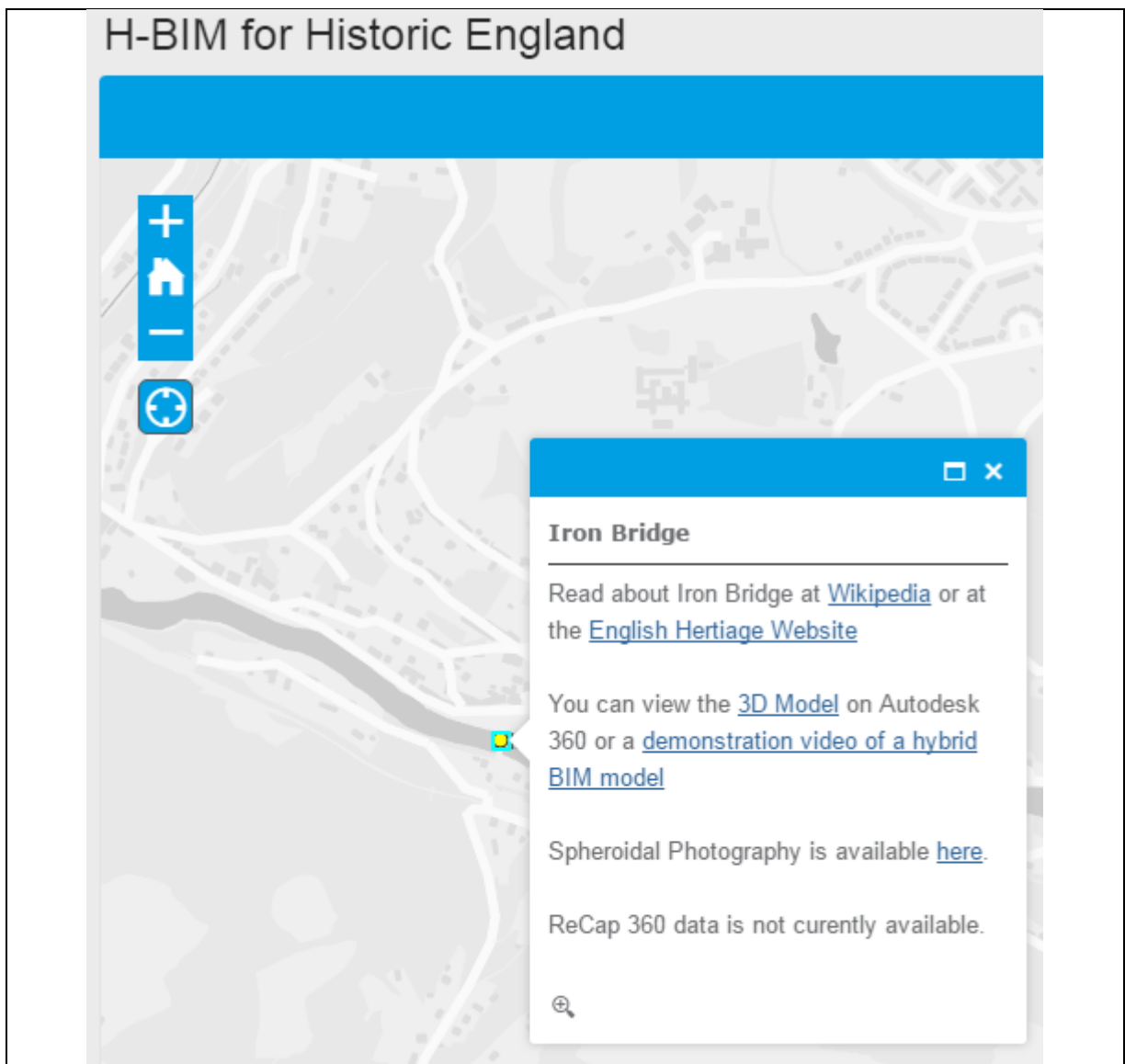

Figure 12-1 GIS for the Iron Bridge site

12.2 Modelling and LoD

The Iron Bridge geometry model was developed using Rhinoceros(16) with the Pointools for Rhino plugin(25). The model was created by using the point cloud survey carried out by APR Services in February 2012. This work was carried out as part of an earlier commission for English Heritage(26) which required an accurate 3D geometry model in order to undertake stress analysis and strength assessment work.

Now using this earlier model for this project it was uploaded to Autodesk 360(14) to illustrate a BIM LoD 3 environment. Figure 12-2 and Figure 12-3 show this model and the basic tools and

manipulation that can be achieved with Autodesk 360. The model can be accessed at <http://a360.co/1TZ00tZ>.

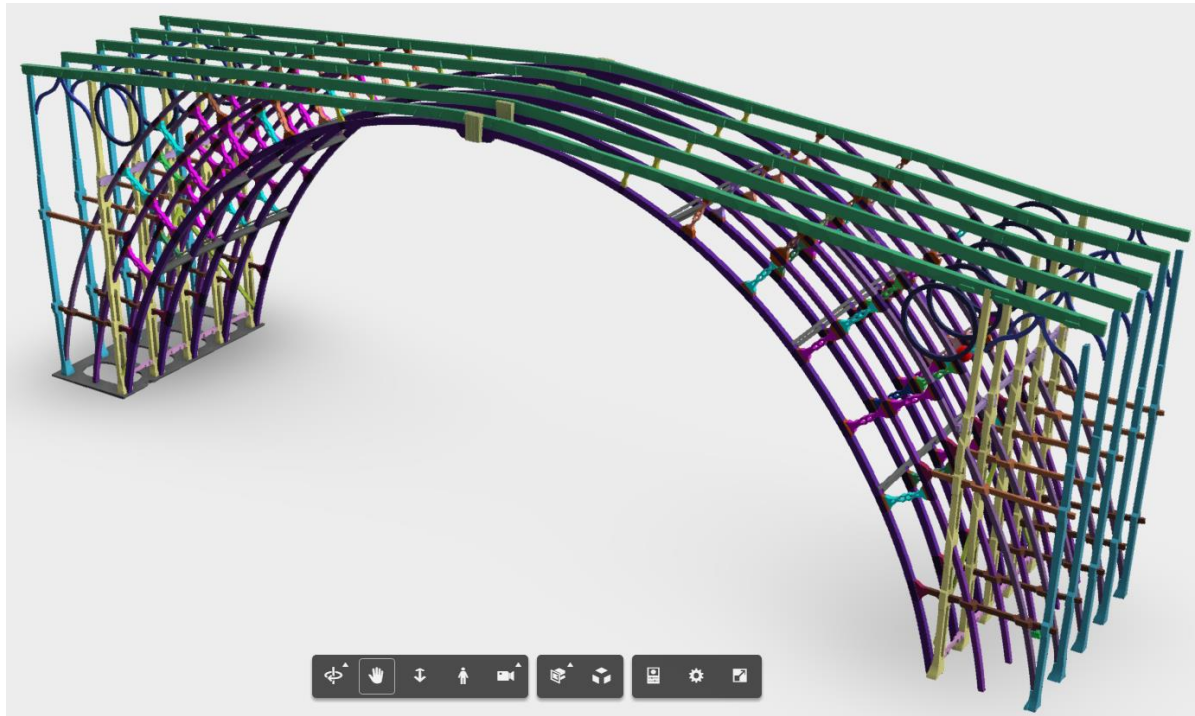

Figure 12-2 Iron Bridge 3D model displayed by Autodesk 360

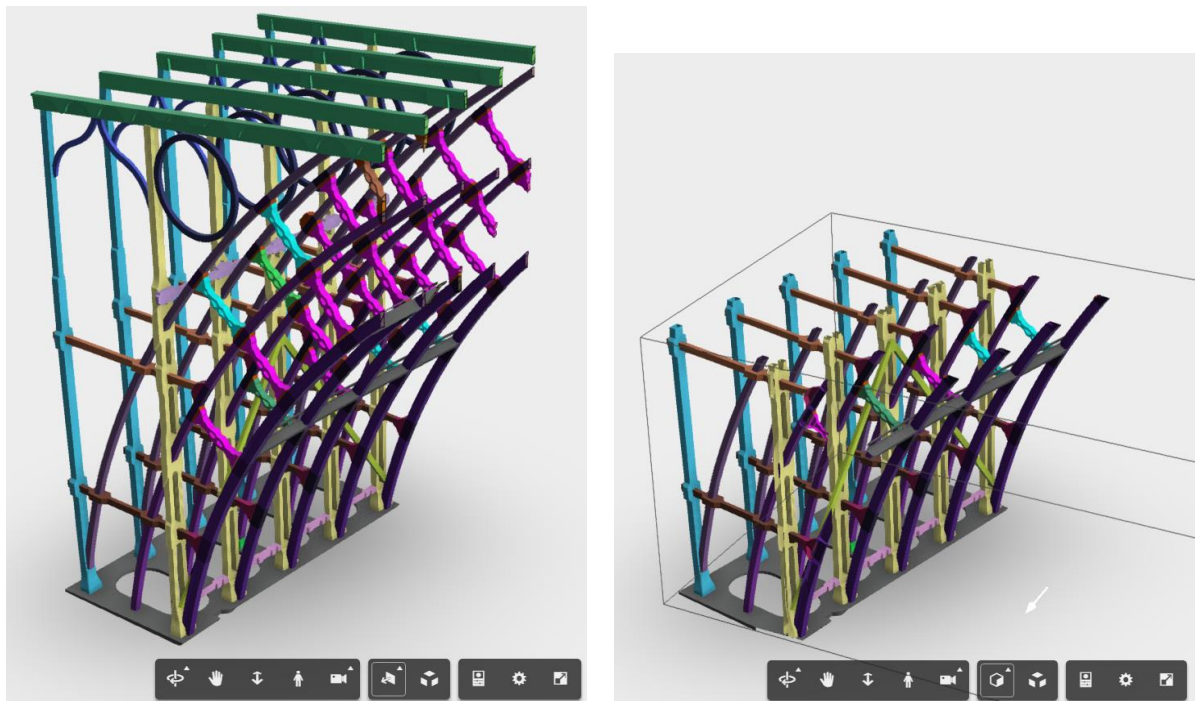

Figure 12-3 Sections cut through the Iron Bridge model in Autodesk 360

Due to the layer structure of the source Rhino model, Autodesk 360 can be used to search through the model and locate individual parts or groups of parts. Additionally, by adding a URL to the object's name in Rhino, the URL becomes usable in Autodesk 360, as shown in Figure 12-4.

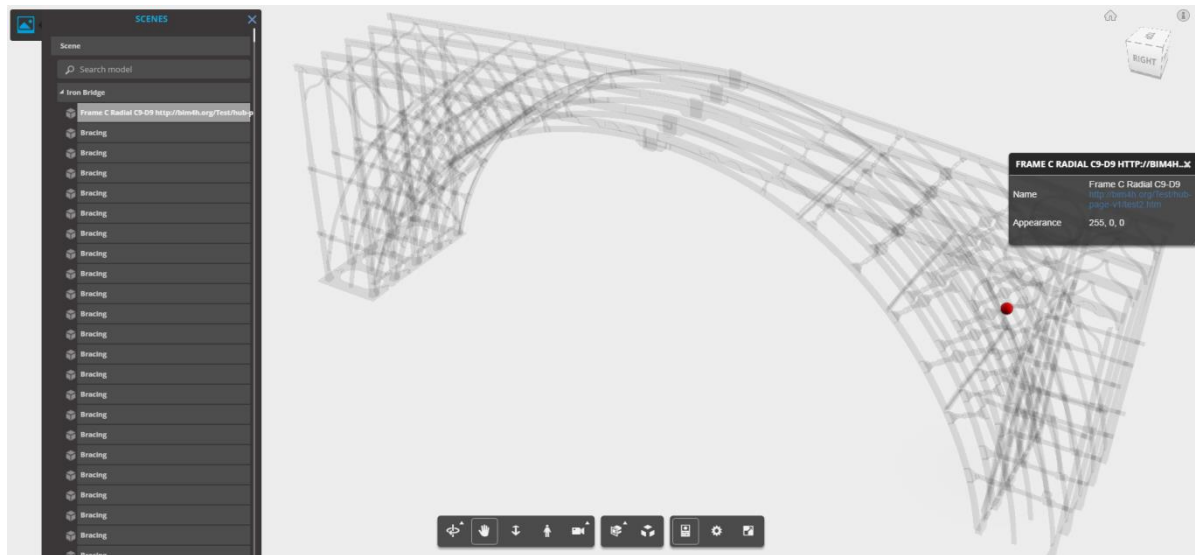
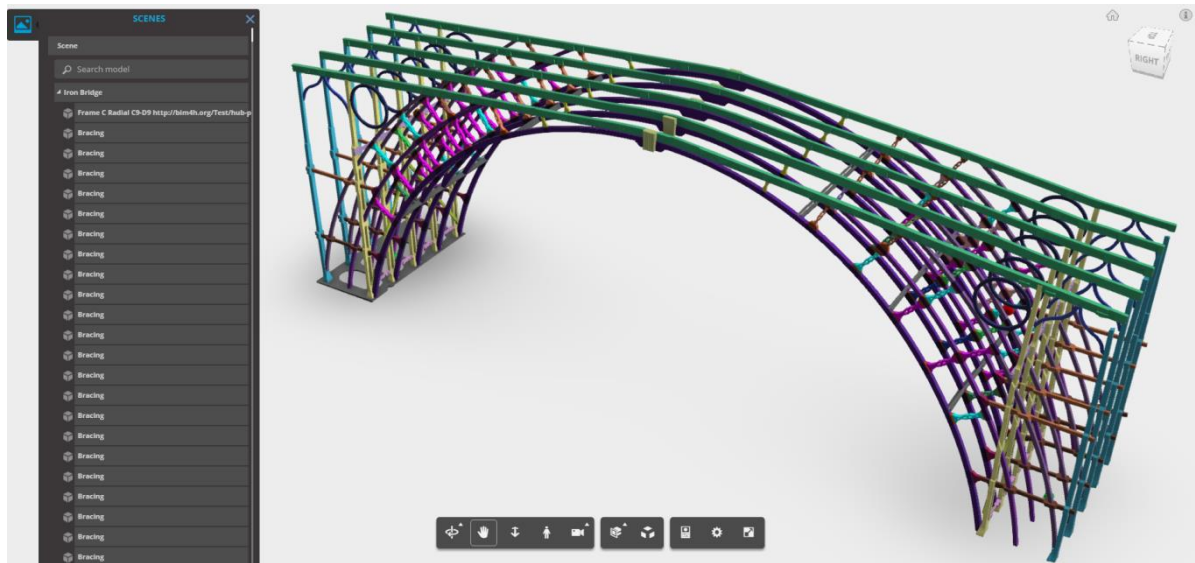

Figure 12-4 Structured model data and 3D markers

The ability to associate URLs with objects has then been used to develop a concept demonstrator of a how a HBIM process whereby markers could be placed throughout the scene, each containing links to relevant information.



REPORT

**IRON BRIDGE,
SHROPSHIRE.**

ROPED ACCESS INSPECTION

OCTOBER 2008 & MAY 2009



Photographs, images and modelled damage and repairs corresponding to Figure Span 1 - Frame C - North Half-span

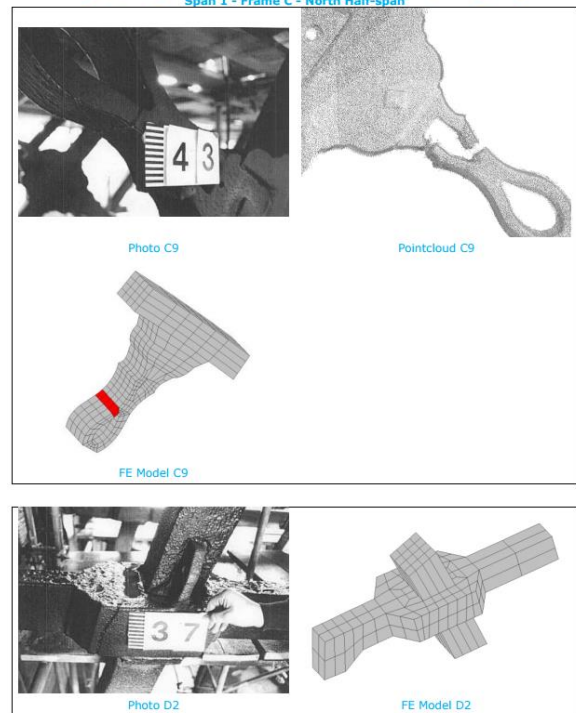
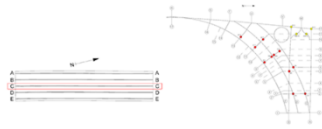

Figure 12-5 Markers linked to a report

It quickly became apparent that each marker might need to link to more than one piece of data, whether that be a report, image, another model or anything else. The best way of dealing with this was to create a Hub Page for each marker, a single place where all the relevant information could be collated. The Hub Page then has further links to any number of documents accessed through a tree of URLs. An example Hub Page is shown in Figure 12-6 with an assortment of data such as type of member and a timeline of defects and repairs. The example Hub Page can be found at <http://bim4h.org/hub-page/index.htm>.

Frame C North Half-span Radial between Grids C9-D9



General Information

This is a radial of Type A.



Timeline

1961
First damage reported.

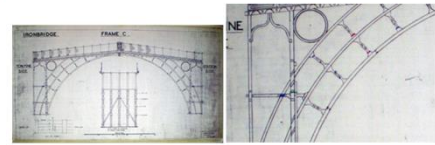

1980
Inspection and photos of damage. Read the full report [here](#).

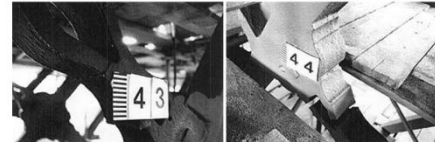

2009
Additional photos of damage. Read the full report [here](#).

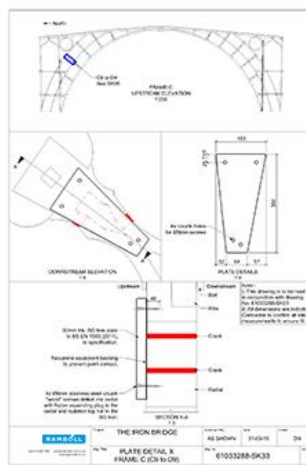
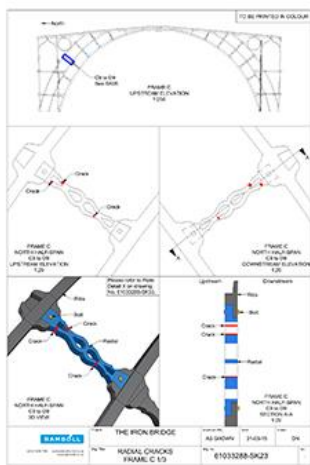

Figure 12-6 Markers linked to a Hub Page

The original Rhinoceros model has also been converted to AutoDesk Revit(16) using the IFC exporting module of the Rhinoceros plugin VisualARQ(27) produced by Asuni CAD. This overcomes the non-standard geometry shapes that are built in Rhinoceros and that are often necessary to represent often unique parts of heritage structures, by using a triangulated mesh. Each part of the model is represented separately so that metadata and links to other types of information can be supported similar to how New-Build BIM is typically handled by Revit. The Revit model can be accessed at <http://a360.co/2jfh56N>.

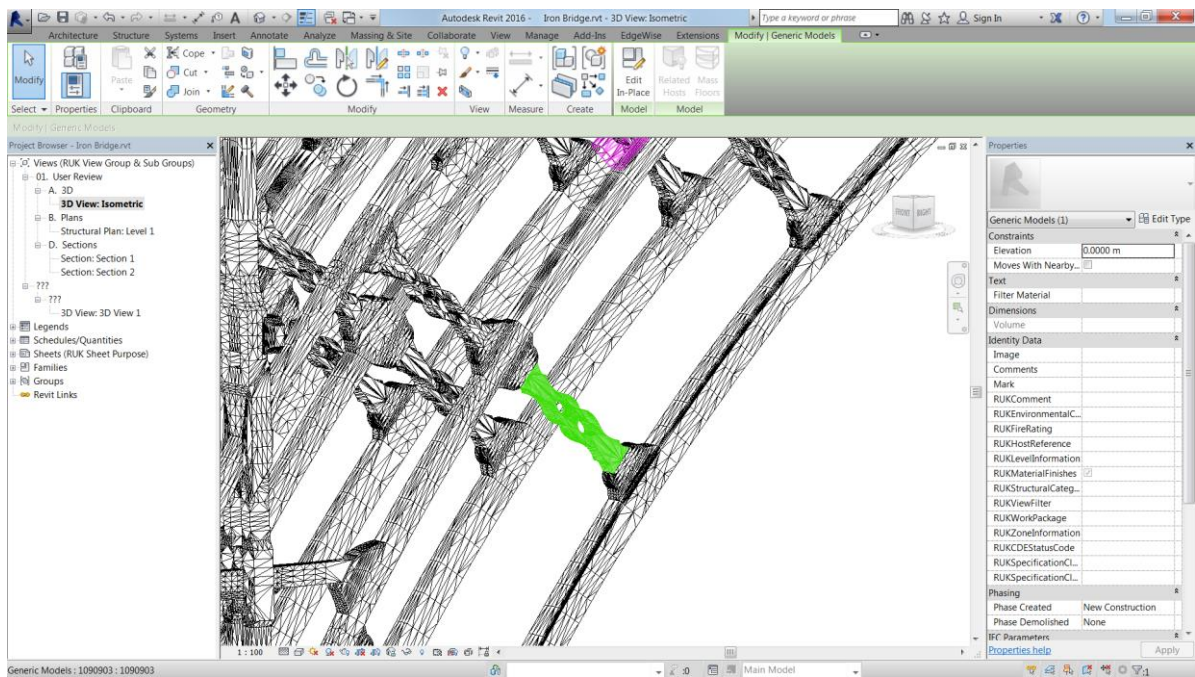
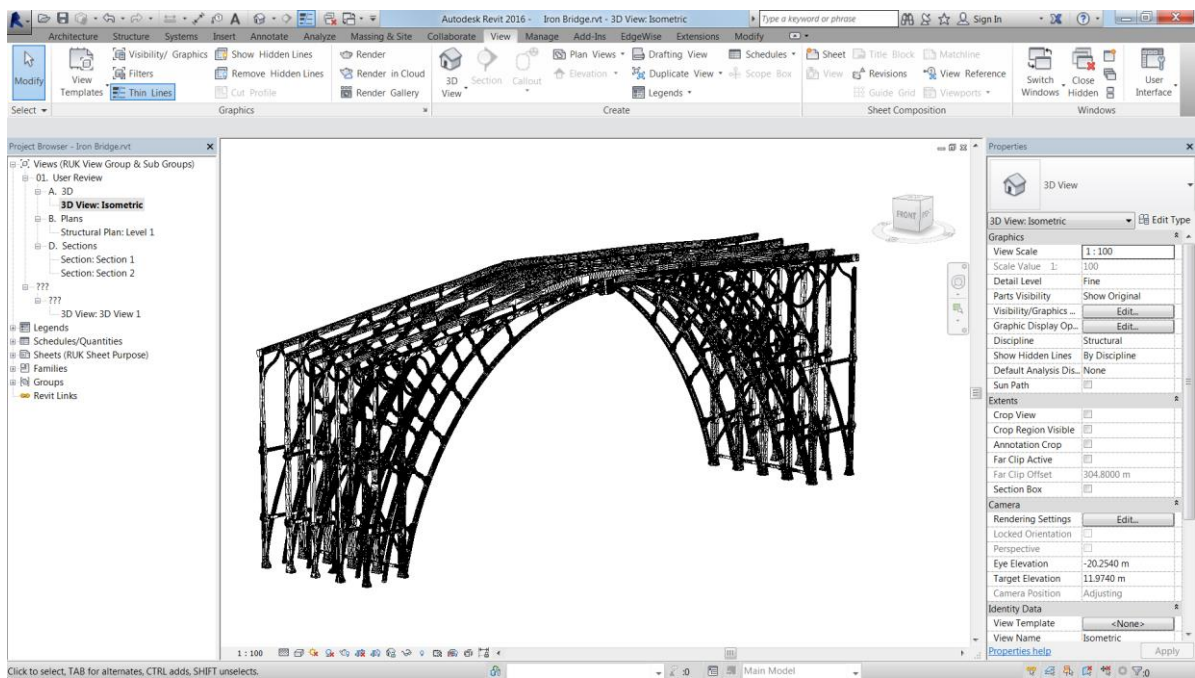

Figure 12-7 IFC file imported into Revit 2016

12.3 Hybrid modelling

The Hybrid modelling technique described in section 3.1 has been demonstrated on the Iron Bridge using Autodesk Revit 2016(16). Two hybrid modelling approaches were tested: using 3D marker objects to tag a location with data (Figure 12-8) and modelling a repair detail to fit the point cloud (Figure 12-9). A demonstration video of the Revit Hybrid modelling process can be seen at <http://bim4h.org/hybrid-model-demo/>.

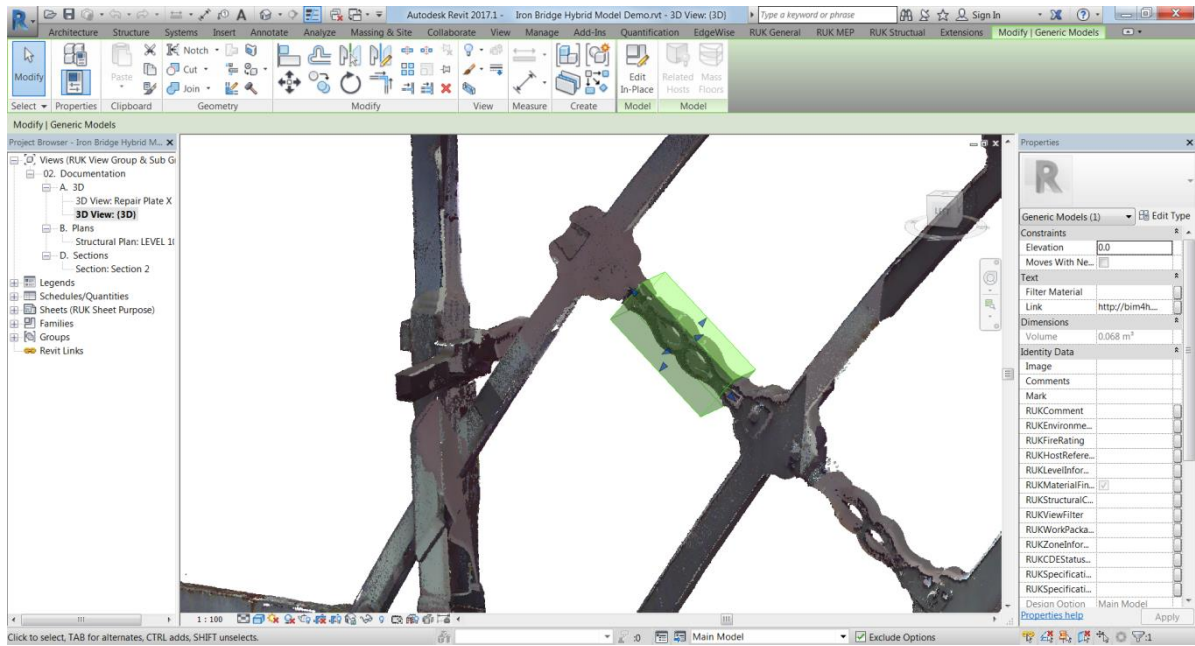

Figure 12-8 3D Marker object in Revit

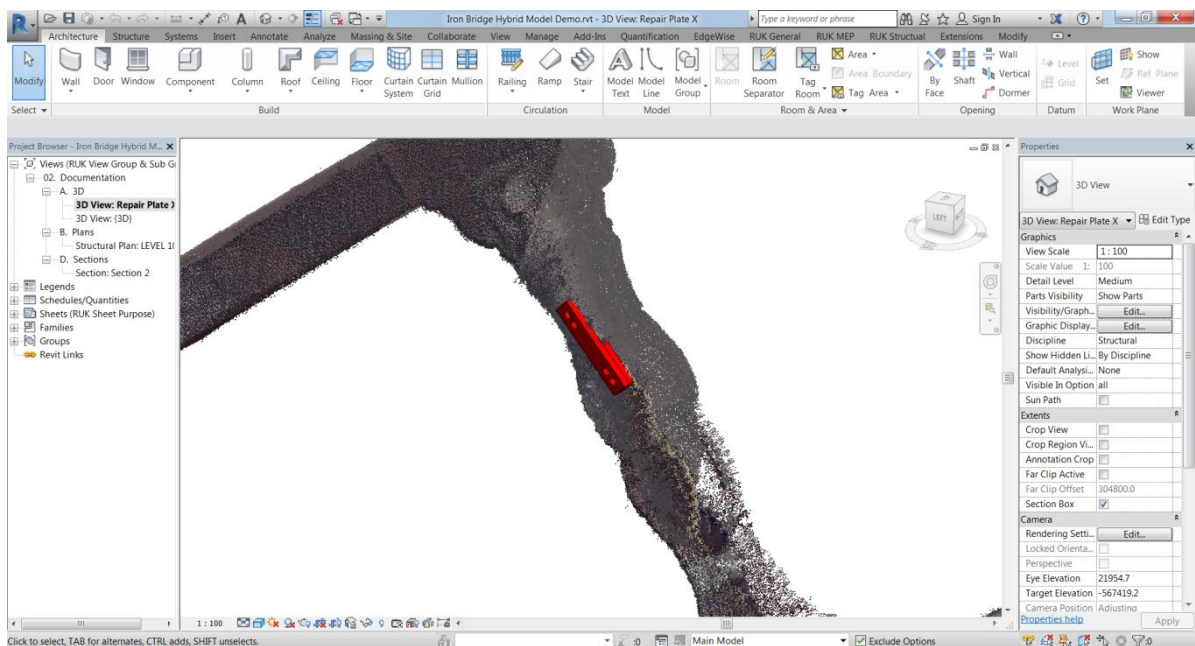

Figure 12-9 Repair detail modelled in Revit to fit the point cloud

12.4 360 degree imagery

360 degree panoramic imagery has been used as a way to navigate the site and carry out simple virtual inspections. The tool is based upon an open-source html 5 viewer called Pannellum(28), supplemented with a simple navigation page. Part of GUI and typical images are shown in Figure 12-10. The 360 degree photos are available at <http://bim4h.org/Iron-Bridge-360/index.htm>.

RAMBOLL IRON BRIDGE - SPHEROIDAL PHOTOGRAPHY

Click on a pink marker below to view the corresponding image.

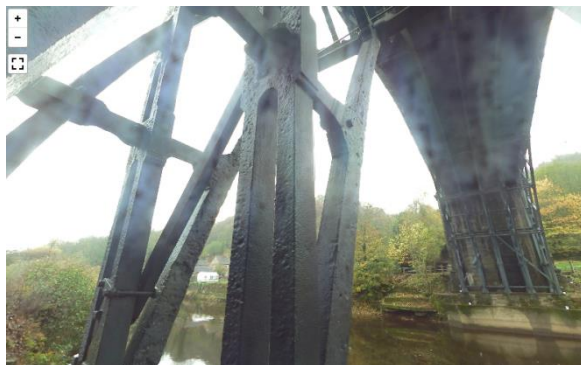
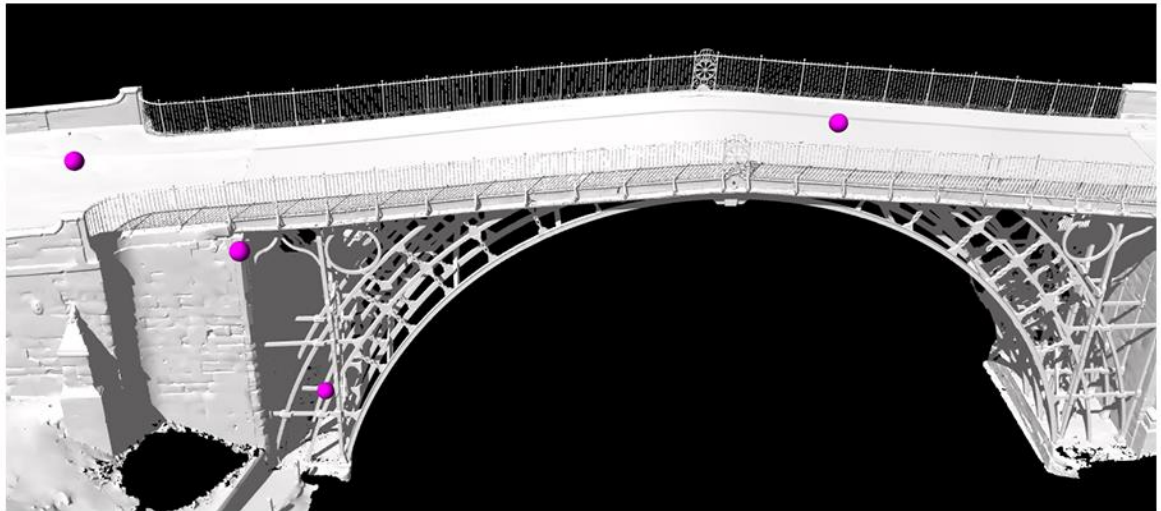

Figure 12-10 Examples of Iron Bride 360 degree imagery

13. CONCLUSIONS

13.1 General

By reviewing current BIM guidelines and practices developed for new-build construction, and considering how these apply to existing assets, in particular the measurement and modelling activities that are required, the following conclusions have been drawn for application to heritage sites.

1. New-build BIM processes have been reviewed to determine which aspects would have most relevance to BIM for management of heritage sites and continuing conservation work. The main difference is that there is no asset information model that is handed over following design and construction. Consequently, collation of existing information (non-graphical information) and a certain amount of modelling (graphical information) will be required before any kind of BIM environment can be developed. To be able to develop a model, the existing geometry will need to be captured by a measurement survey. This process is additional to those normally encountered in new-build BIM.
2. New-build BIM is developed with increasing level of modelling detail and information as design and construction proceeds, and follows the CIC stages. At the end of construction a project information model is handed over to the client which becomes the asset information model and a key resource for future asset management. Stages in the development of BIM for heritage are completely different and relate to factors such as the significance and value of the asset, the survey and information requirements, and the scale of any intervention. It is quite likely BIM would be applied to new restoration work and would proceed in an iterative way adding more information to the overall model for each phase of work and through time.
3. As measurement is so important to establish any kind of geometry model, different survey techniques have been examined which are most likely to be useful in providing the datasets for BIM for heritage, and a classification system developed. Mass data capture technologies such as 3D laser scanning and digital photogrammetry that produce point clouds are amongst the most effective way of measuring the existing environment. The classification system ranks surveys in terms of likely cost and complexity, measurement range and point cloud density. Potential uses for each class of survey have also been given. These survey classes are then referred to in tables that define different levels of model detail for BIM.
4. The relationship of level of modelling detail, type of survey and different uses of BIM have been considered and tables have been developed that set out four levels of modelling detail. This scheme covers 3D, 2D and hybrid modelling. For each level of detail, survey classes are given that indicate the type of survey required that would be necessary to develop the datasets with appropriate resolution. Examples of each modelling level have been developed using both the Iron Bridge and Harmondsworth Barn datasets.
5. The datasets for both the Iron Bridge and Harmondsworth Barn have been developed, in part, to illustrate BIM with different levels of detail. These models have been delivered electronically as part of this project and, for instance, include a Revit model of The Iron Bridge.
6. Hybrid model environments have also been explored and different usages and levels of modelling detail suggested. The use of hybrid environments, point cloud and mesh based, is likely to provide major advantages over fully object based BIM as the time and effort of modelling the existing asset is avoided. Also, assumptions relating to verticality of walls and horizontality of floors and other idealisations of geometry which are necessary simplifications

for new-build BIM modelling software such as Revit are avoided. Instead, the hybrid environment allows the true geometry to be used.

7. A web domain has been set up to illustrate how BIM for heritage could be organised for an estate. This uses a searchable GIS environment to access data at the two different sites, various viewers to visualise the sites and their point clouds, and several models with different levels of detail. URLs to access this web site as well as the models used to illustrate different aspects of BIM are included in this report.
8. The examples facilitated with the web site are fully Cloud based and simply use a web browser to access. Apart from helping to illustrate the modelling work carried out for this project the domain also shows the potential for Cloud based processes that allow different organisations to work collaboratively in a common environment. Working this way should allow different organisations to interact with BIM, once it has been created, without needing to make major investments both in software and training.
9. Harmondsworth Barn datasets from different periods have also been compared to show how models can be used to visualise changes. These changes can be both small and large. Understanding small changes is useful for condition and movement monitoring. Visualising large changes is a rapid way of showing whether parts are missing or have been introduced. Both are seen as useful techniques in asset management of heritage sites and could be part of their BIM environments.
10. Additional datasets for Harmondsworth Barn have been obtained by using a hand held laser scanner and the results compared with those obtained with a conventional tripod mounted 3D laser scanner. Datasets compared well, although one of the four handheld surveys could not be used. The only real difference being the reduced number of points recorded. The lack of intensity in the point cloud data (GeoSLAM Zeb-REVO) meant the data was difficult to use directly for modelling and visualisation. Using in-house and third party software different techniques have been used to add intensity and colour values to the point cloud.

13.2 Recommendations

The following recommendations have been made that in some cases would involve further studies and examination of datasets and asset management systems operated by English Heritage and Historic England.

1. It has not been possible to interact in any way with the K2 estate asset management system used by English Heritage. It is understood that there has been a programme of work to upload information on all heritage sites run by English Heritage in a standardised way. Given this, it is recommended that work is undertaken to see how existing and structured information on these sites could be integrated at estate level with GIS and at site level with BIM. The K2 asset management system might be the first place to visit to access BIM for a particular site.
2. It has been difficult to set out and classify the level of information (non-graphical information) that is expected to combine with level of detail (graphical information) to give overall level of model detail for BIM. It is suggested that from knowledge of the different types of conservation work that is carried out, a classification system is developed that could be linked to level of information in the same way that it has been possible to link surveys to level of detail.
3. In considering survey technology classification the significance of local position systems (LPS) within buildings has been considered although has not been part of this project. Different LPS technology is emerging which allow objects and people to be positioned in 3D space within buildings and estates to within 0.2m. A potential application for heritage work is to use LPS to locate field notes, sketches and photographs within BIM automatically. For instance, a

photograph or note is automatically located in the right place within BIM at the time the information is collected on site.

4. The handheld laser survey (GeoSLAM zeb-REVO) and modelling work carried out at Harmondsworth Barn warrants a separate report to collate all findings, and to develop best practice for using this type of surveying instrument.
5. Although not covered as part of this project the Uniclass system(29) developed for new-build should be reviewed to see how much of it could be used for heritage BIM. For instance, top levels may work well that indicate in broad terms the object type, but the detail that is introduced for the latter CIC stages of BIM to allow production and manufacture would almost certainly be inappropriate. Heritage involves often unique things and systemising to cover everything explicitly could never be justified as there will be no repeats. A Uniclass lite (top of pyramid) with additional commentary is the likely way forward.
6. Engaging with software developers i.e. Autodesk with regard to hybrid modelling. In particular, features to help enable Hybrid HBIM in Revit. Some examples are given below.
 - A new object type "3D Marker" that can be attached to any coordinate in 3D space (or any view) including from a point cloud. The 3D Marker would contain data like any other object type in Revit. This could also be used for URLs to other documents and models.
 - A new object type "Point cloud Voids". These would work exactly like regular Revit voids except that they would only affect the selected point cloud(s). So for example the user could create a simple void extrusion and cut out the points in that region. Currently this would need to be manually carried out in ReCap 360 Pro by selecting regions of points and deleting them. It also involves a convoluted process to transfer the Revit geometry via Navisworks into ReCap 360 Pro.
7. Although some mesh based hybrid model datasets have been created as part of this work, the use of these datasets within a HBIM environment has not been explored. As with the point cloud based hybrid HBIM usage explained previously, it is expected that the existing tools and capabilities of BIM software will fall short of what is needed to make this type of data usable for heritage activities. At the very least some best practises could be developed so that these kinds of tools can be used in a BIM environment.

14. REFERENCES

1. AutoDesk AutoCAD
2. PAS 1192-2:2013 Incorporating Corrigendum No. 1 Specification for information management for the capital/delivery phase of construction projects using building information modelling.
3. NBS. LoMD for Heavy Steel Framing Systems. https://toolkit.thenbs.com/definitions/Ss_20_10_75_35/
4. BIM Task Group. BIM Employer's Information Requirements (EIR). <http://www.bimtaskgroup.org/bim-eirs/>
5. BS 1192:2007 + A2:2016 Collaborative production of architectural, engineering and construction information – Code of practice.
6. Maxwell I. COTAC BIM4C Integrating HBIM Framework Report Part 1: Conservation Parameters. February 2016.
7. buildingSMART. The international home of open BIM. <http://buildingsmart.org/>
8. PAS 1192-3:2014 Incorporating Corrigendum No. 1 Specification for information management for the operational phase of assets using building information modelling.

9. English Heritage. Conservation Maintenance Programme 2015/16 to 2022/23. <http://www.english-heritage.org.uk/content/imported-docs/a-e/conservation-maintenance-programme-201516-to-202223.pdf>
10. AEC (UK) BIM Protocol Implementing UK BIM Standards for the Architectural, Engineering and Construction industry. Version 2.0 September 2012
11. NBS. BIM Levels of Information. <https://www.thenbs.com/knowledge/bim-levels-of-information>
12. Historic England. Metric Survey Specifications for Cultural Heritage. 2015
13. Maxwell I. COTAC BIM4C Integrating HBIM Framework Report Part 2: Conservation Influences. February 2016.
14. ESRI. ArcGIS Online. 2017. <http://www.esri.com/software/arcgis/arcgisonline>
15. Autodesk 360. <https://a360.autodesk.com/>
16. Rhinoceros. <https://www.rhino3d.com/>
17. Autodesk Revit 2015 and 2016 <http://www.autodesk.co.uk/products/revit-family/overview>
18. Edgewise. <http://www.clearedge3d.com/products/edgewise-bim-suite/>
19. Agisoft PhotoScan. <http://www.agisoft.com/>
20. Autodesk ReCap. <http://www.autodesk.com/products/recap-360/overview>
21. Autodesk ReMake. <https://remake.autodesk.com>
22. Nctech iSTAR. <https://www.nctechimaging.com/istar/>
23. Adobe Photoshop. <http://www.adobe.com/uk/products/photoshop.html>
24. CloudCompare. 3D point cloud and mesh processing software Open Source Project. <http://www.cloudcompare.org/>
25. Pointools. https://www.bentley.com/en/products/product-line/reality-modeling-software/bentley-pointools?skid=CT_PRT_POINTOOLS_B
26. Ramboll. The Iron Bridge, desk study, modelling, analysis and assessment. Report no. 61020351-S-R01 Rev B 05/02/2014.
27. VisualARQ. Flexible BIM for Rhino <http://www.visualarq.com/info/ifc/>
28. Pannellum. Pannellum is a lightweight, free, and open source panorama viewer for the web. Built using HTML5, CSS3, JavaScript, and WebGL, it is plug-in free. <https://pannellum.org/>
29. NBS. Uniclass 2015. <https://www.thenbs.com/services/our-tools/introducing-uniclass-2015>

APPENDIX 1

LOD VISUAL EXAMPLES

This appendix shows larger versions of the visual images used in the LoD tables. The images are not annotated or labelled but appear in the same order as they are used in the LoD tables in the report.

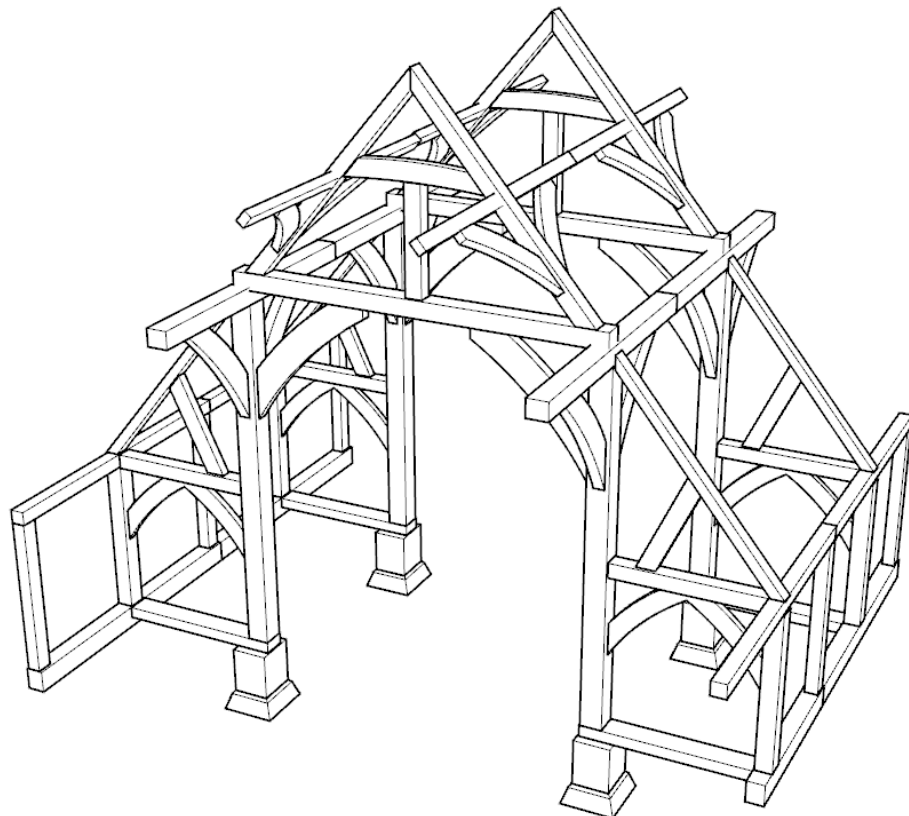
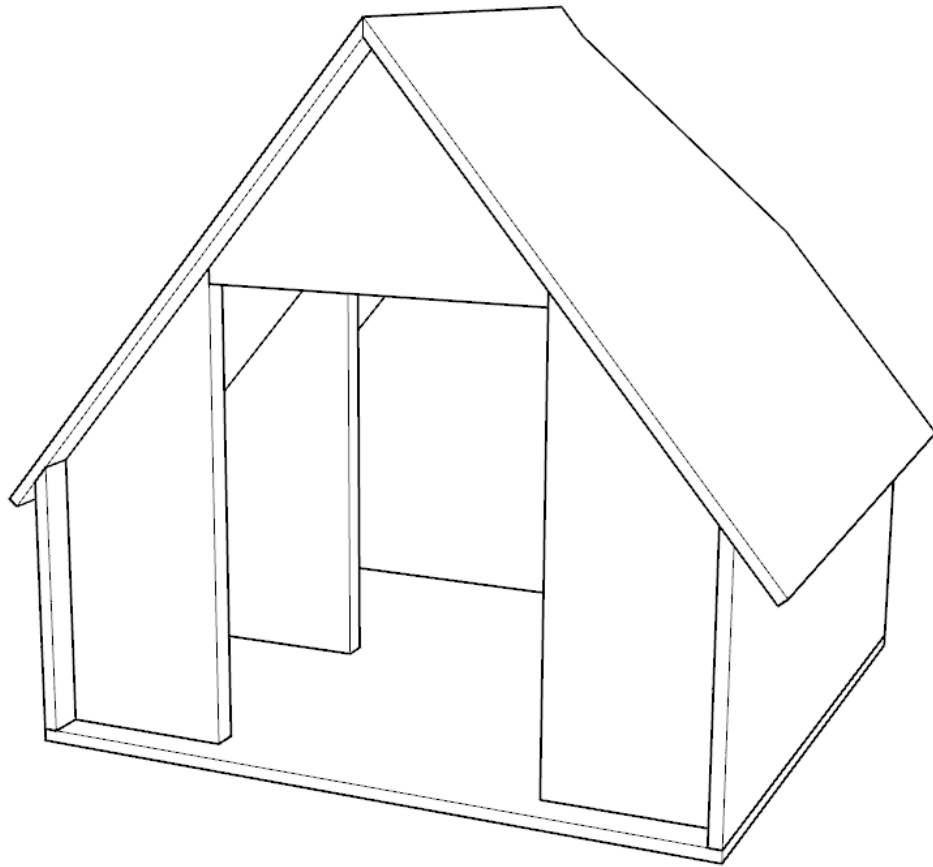

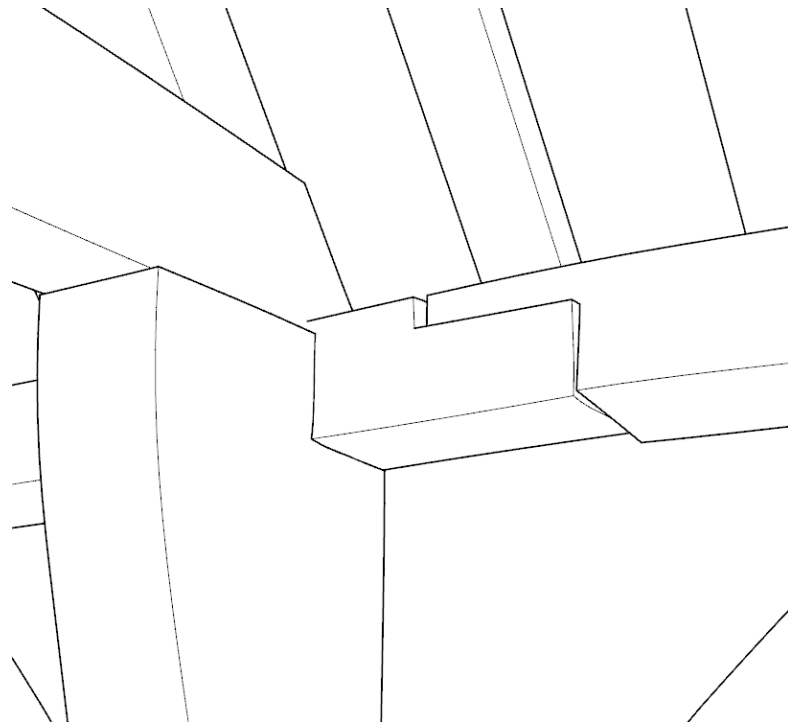
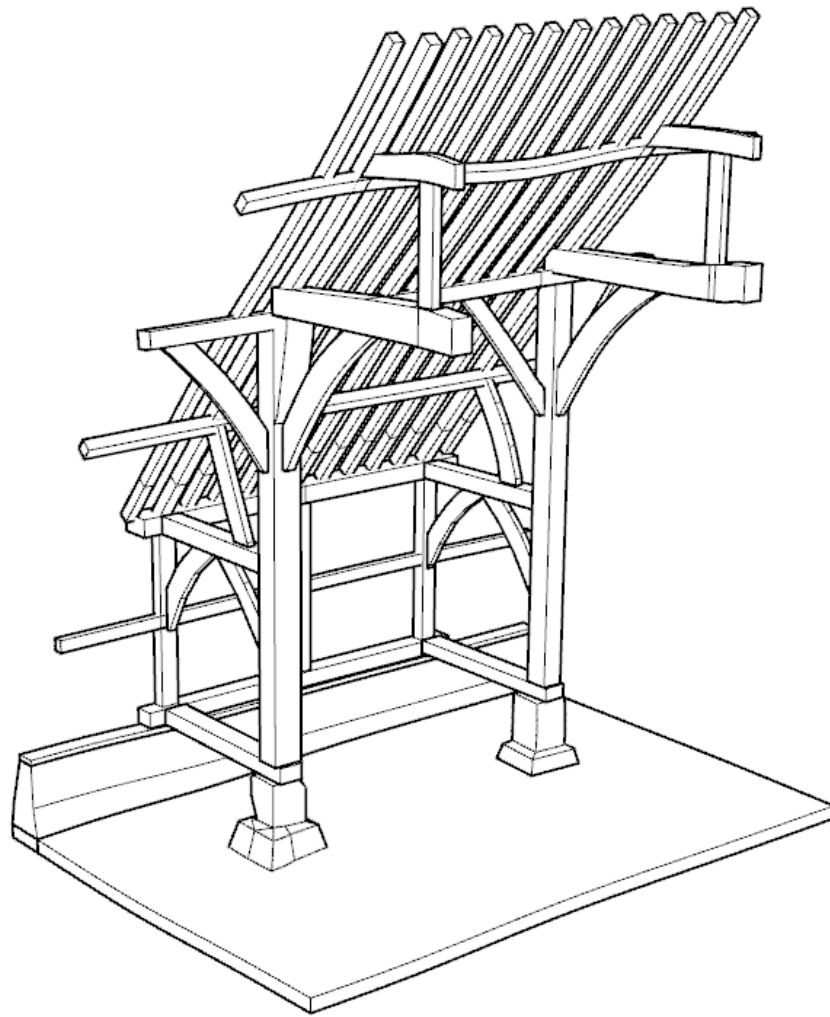

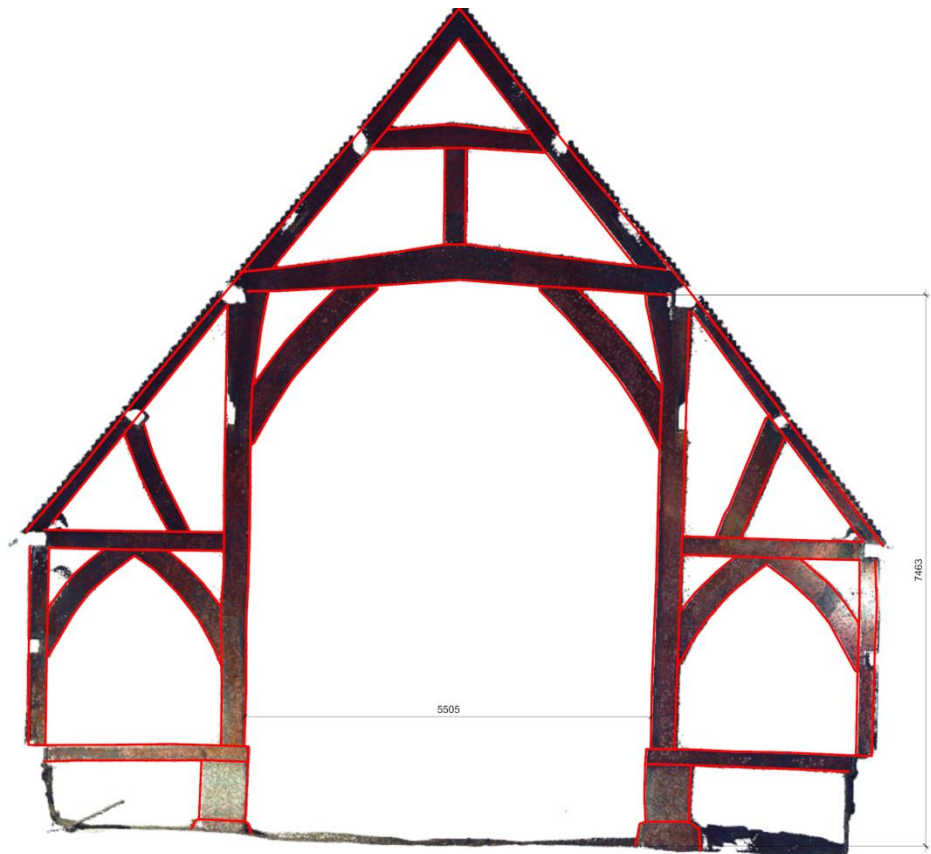
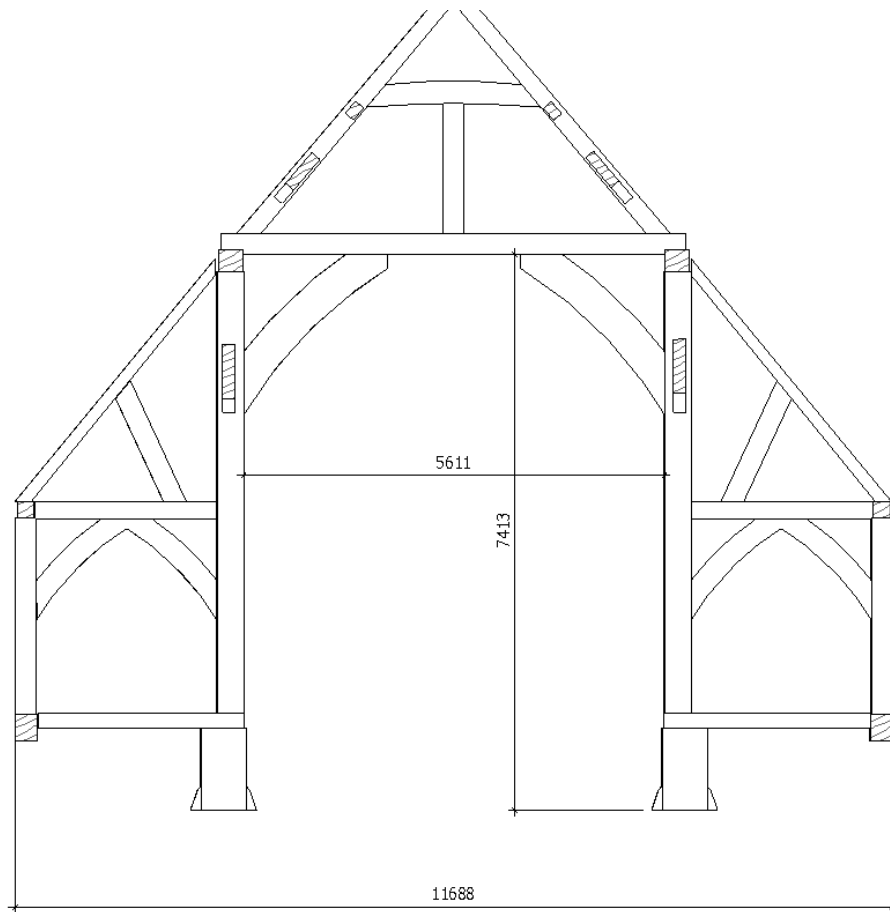



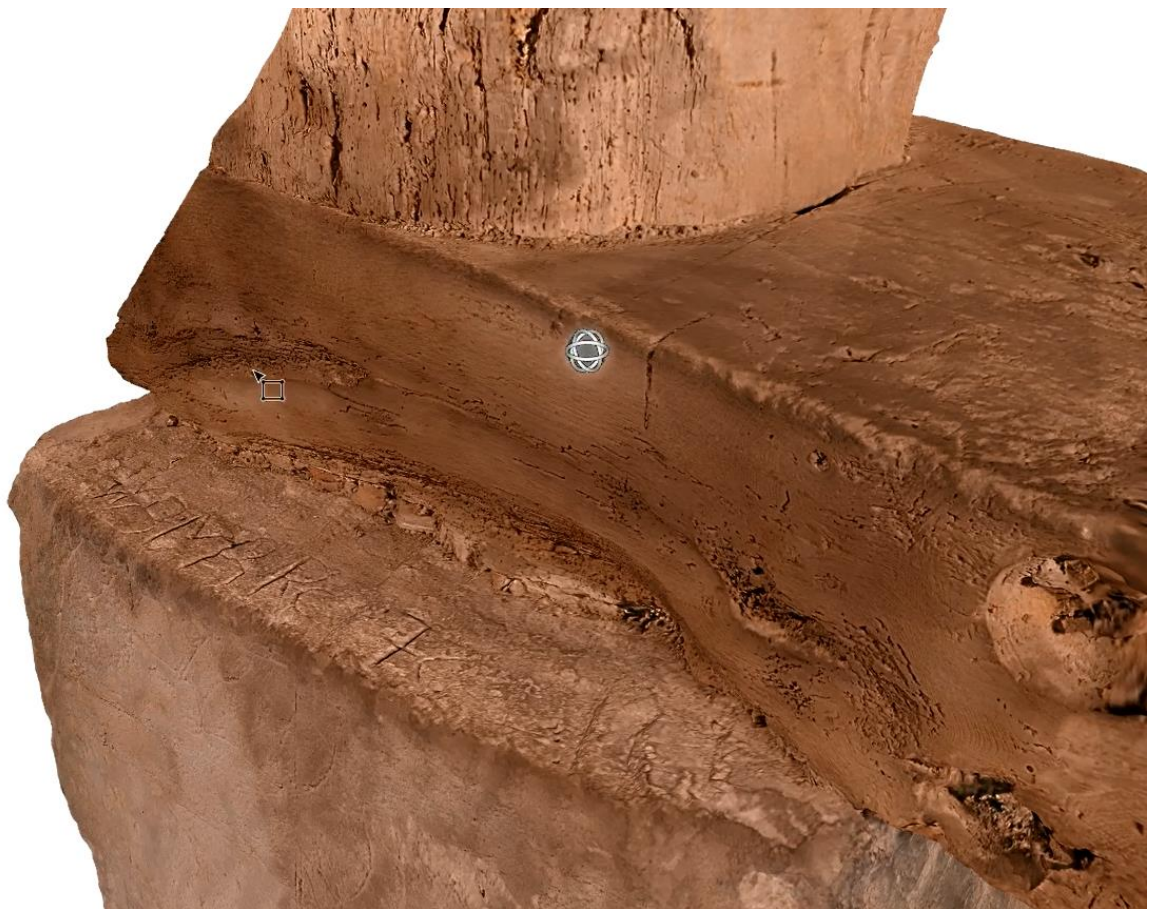

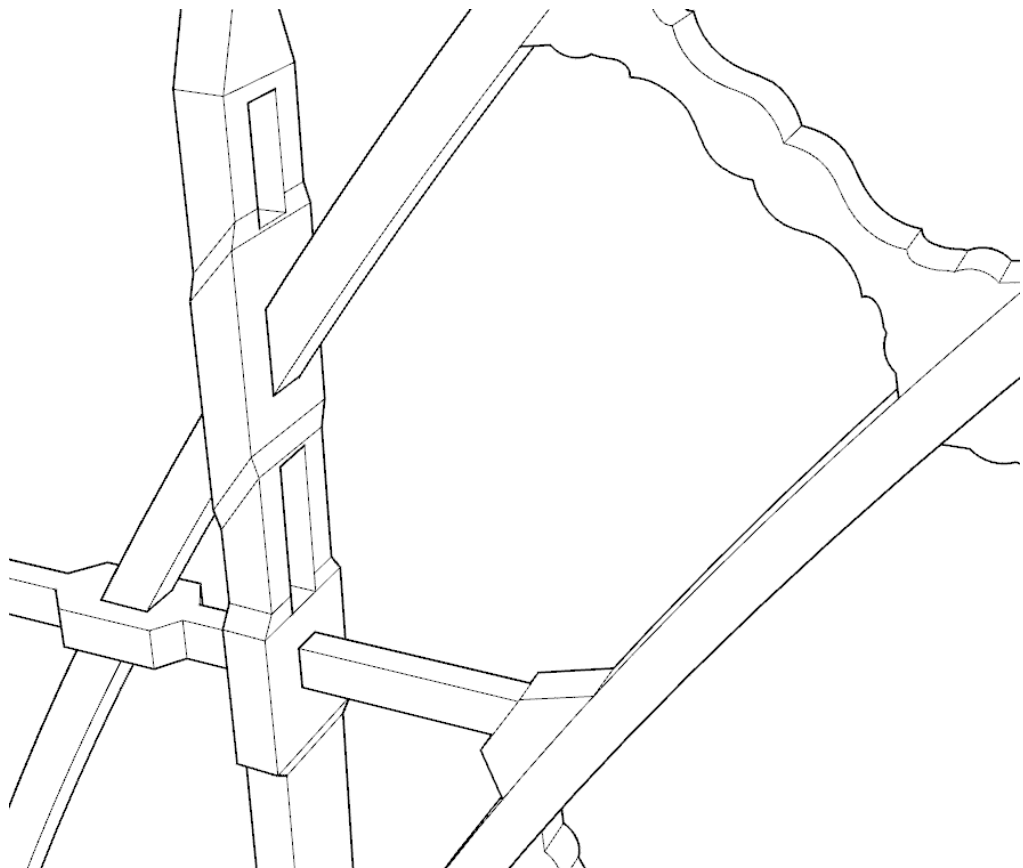
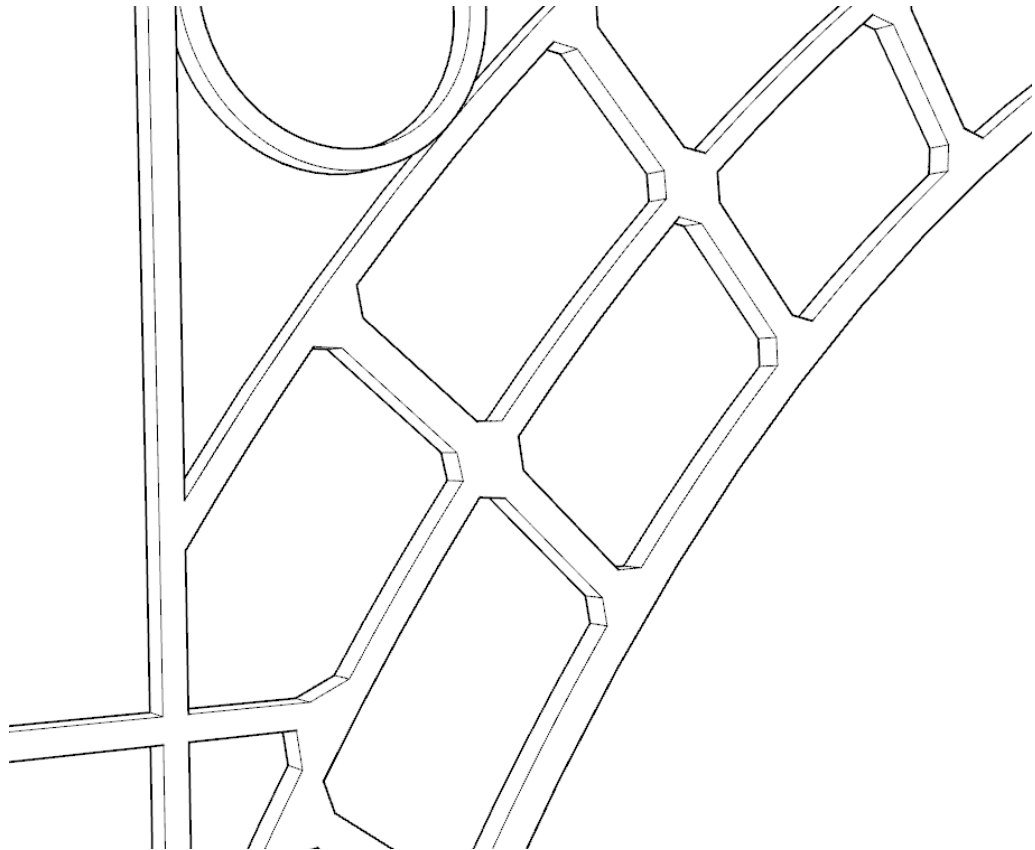

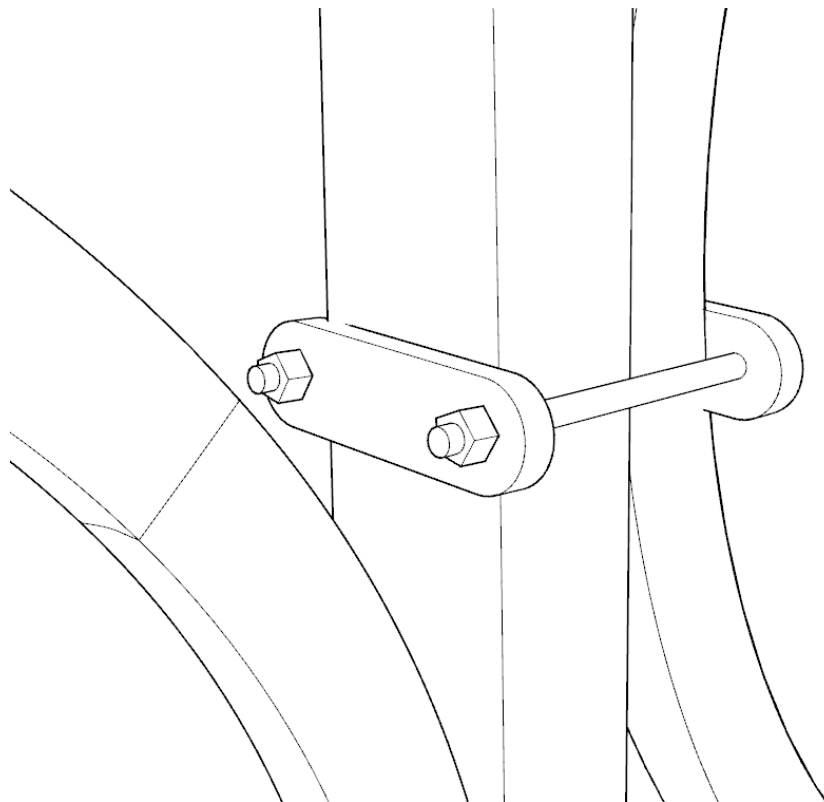
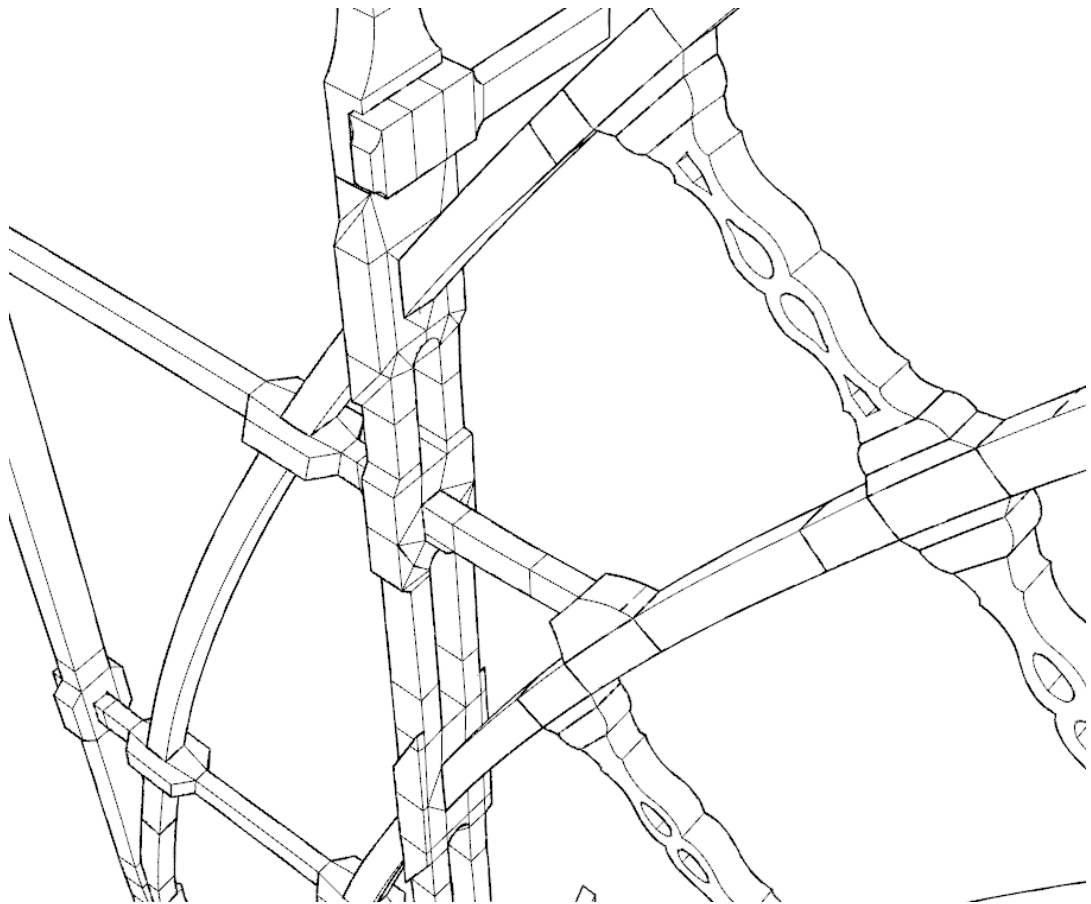

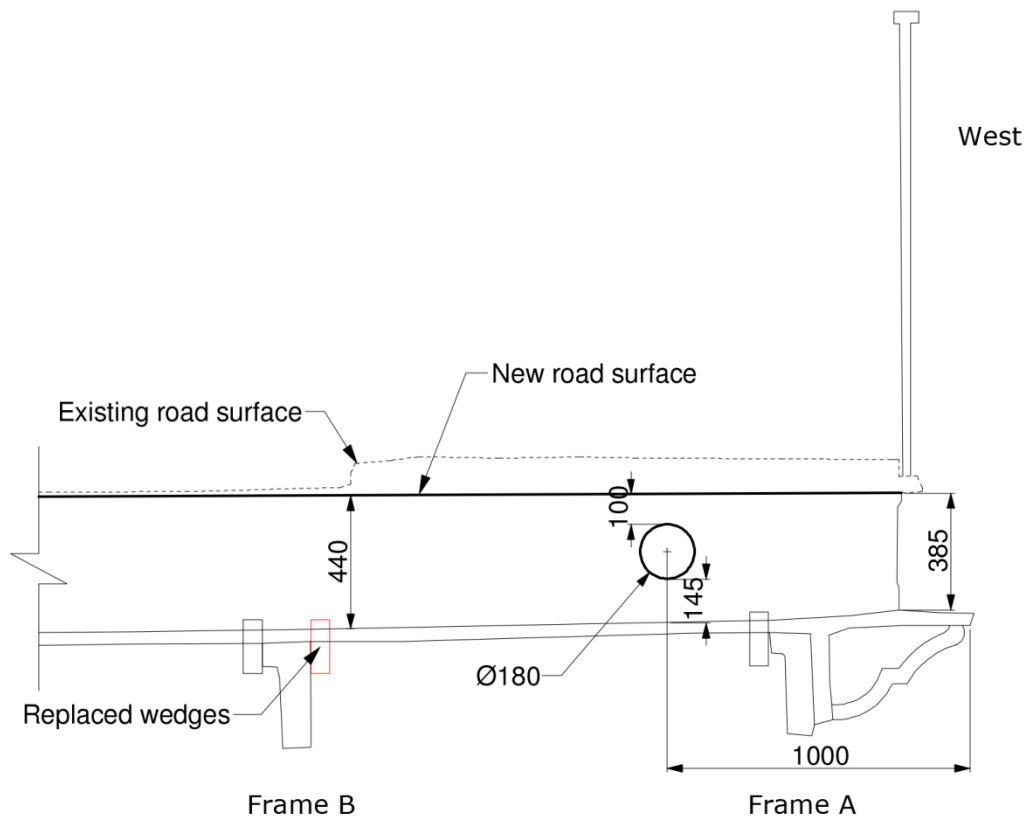
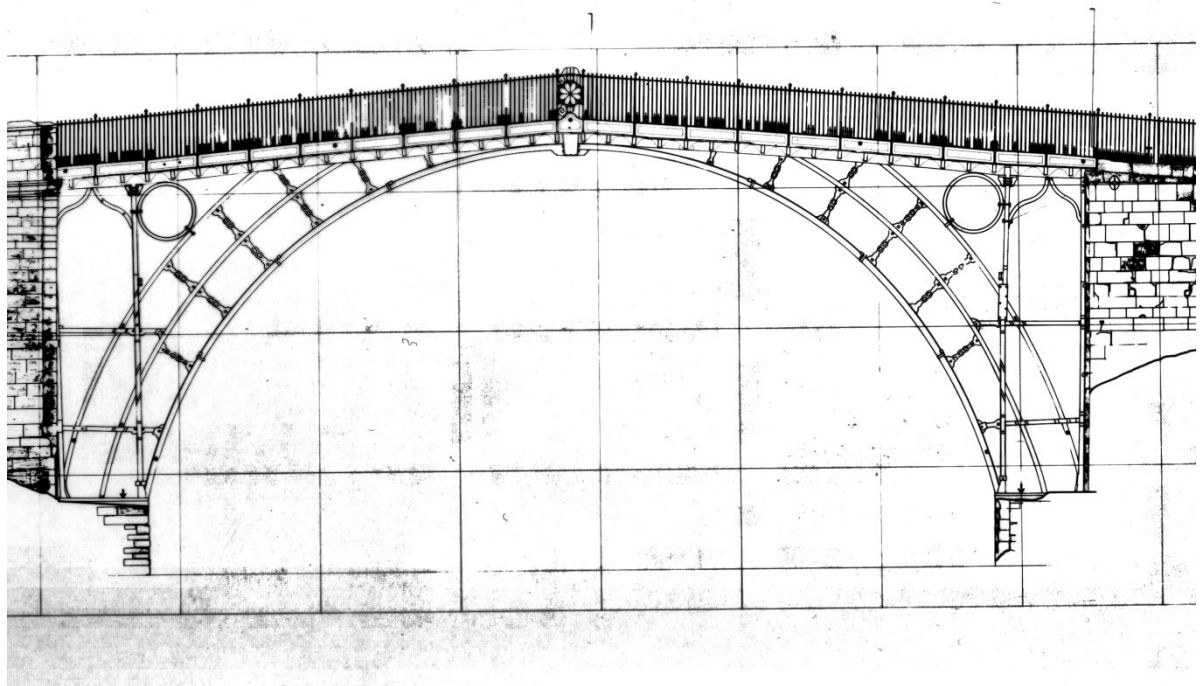

Scale 1:25

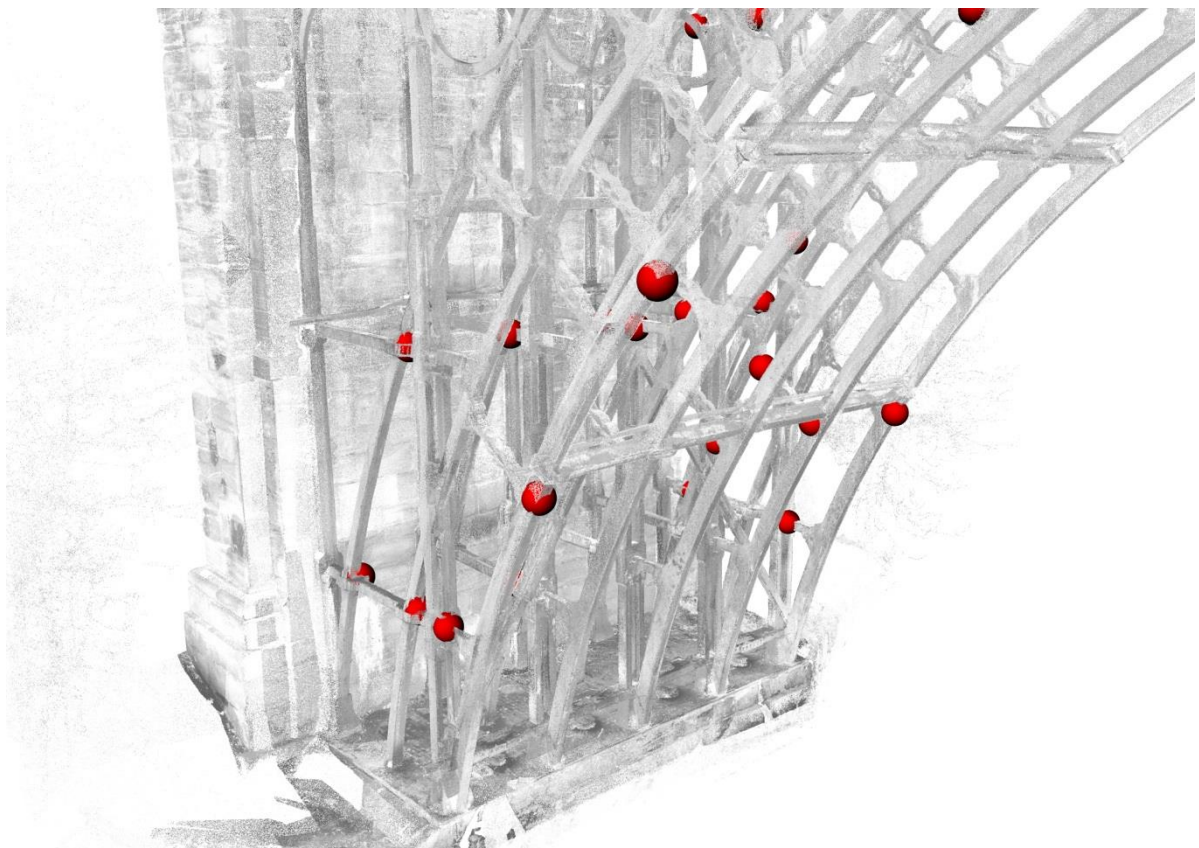

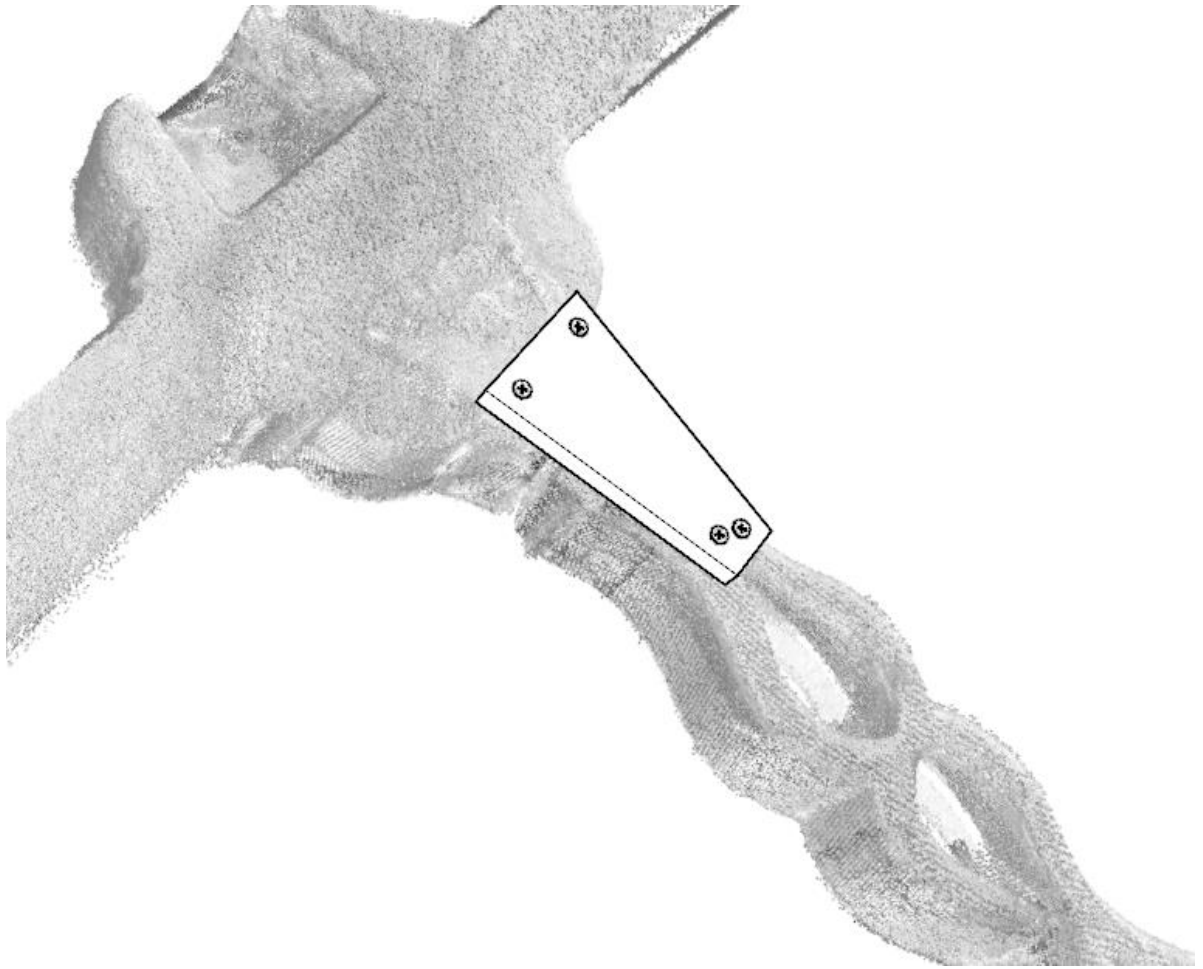



Historic England Research and the Historic Environment

We are the public body that looks after England's historic environment. We champion historic places, helping people understand, value and care for them.

A good understanding of the historic environment is fundamental to ensuring people appreciate and enjoy their heritage and provides the essential first step towards its effective protection.

Historic England works to improve care, understanding and public enjoyment of the historic environment. We undertake and sponsor authoritative research. We develop new approaches to interpreting and protecting heritage and provide high quality expert advice and training.

We make the results of our work available through the Historic England Research Report Series, and through journal publications and monographs. Our online magazine Historic England Research which appears twice a year, aims to keep our partners within and outside Historic England up-to-date with our projects and activities.

A full list of Research Reports, with abstracts and information on how to obtain copies, may be found on www.HistoricEngland.org.uk/researchreports

Some of these reports are interim reports, making the results of specialist investigations available in advance of full publication. They are not usually subject to external refereeing, and their conclusions may sometimes have to be modified in the light of information not available at the time of the investigation.

Where no final project report is available, you should consult the author before citing these reports in any publication. Opinions expressed in these reports are those of the author(s) and are not necessarily those of Historic England.

The Research Report Series incorporates reports by the expert teams within the Investigation & Analysis Division of the Heritage Protection Department of Historic England, alongside contributions from other parts of the organisation. It replaces the former Centre for Archaeology Reports Series, the Archaeological Investigation Report Series, the Architectural Investigation Report Series, and the Research Department Report Series