



Historic England

Building and Landscape Conservation

Conserving Stained Glass using Environmental Protective Glazing

Tobit Curteis and Léonie Seliger

Discovery, Innovation and Science in the Historic Environment



Conserving Stained Glass Using Environmental Protective Glazing

Prepared for Historic England by

Tobit Curteis, Tobit Curteis Associates
and Léonie Seliger, Canterbury Cathedral Stained Glass Studio
in association with
Naomi Luxford, Shane Slater, Tracy Manning, and Robyn Pender

© Historic England

ISSN 2059-4453 (Online)

The Research Report Series incorporates reports by Historic England's expert teams and commissioned reports. The series replaces the former Centre of Archaeology Report Series, the Archaeological Investigation Report Series, the Architectural Investigation Report Series, the Research Department Report Series.

Opinions expressed in Research Reports are those of the author(s) and not necessarily those of Historic England.

For more information contact Res.reports@HistoricEngland.org.uk or write to Historic England, Conservation Department, The Engine House, Fire Fly Avenue, Swindon, SN2 2EH

Front cover: Glass sensors in place on the internal and external faces of the glazing at Holy Trinity Church, Long Melford. © Tobit Curteis Associates

BACKGROUND TO THE RESEARCH

Because stained-glass windows form part of the building envelope – separating the internal and external environments – they are uniquely vulnerable to aggressive environmental deterioration. On the exterior, rainfall, wind and pollution can cause structural and chemical deterioration of the glass and the leading; on the interior, condensation can cause irreversible loss of paint and other applied decoration.

Unfortunately, our ability to improve the environmental conditions to which historic glass is subjected is limited. One of the few interventions available that can provide protection whilst keeping the historic glass *in situ* is secondary glazing, in the form of Environmental Protective Glazing.

The term ‘Environmental Protective Glazing’ (EPG) describes secondary glazing systems where the principal purpose is reducing the impact of microclimatic conditions on historic glazing (as opposed to systems intended primarily to provide protection from impact).

EPG has been used in one form or another since the 19th century, but while considerable design developments have taken place over that time, there have remained many lacunae in our understanding of how the system actually works.

The confusion over technical aspects of EPG is highlighted by its popular name, ‘isothermal glazing’; as this Research Report shows, the success of EPG actually depends on temperature differences.

Historic England is regularly consulted about the merits and justifications of EPG systems for stained glass conservation. Since the remit of the organisation is to care for the historic environment as a whole, we do have concerns that, if the design of the EPG system is not approached with sufficient care and attention, the benefits to the glass can sometimes be at the expense of other historic elements, including the appearance of the window in its setting, and the exterior views of the building. EPG is not a universal panacea: as ever with conservation, the undoubted gains must be balanced against the negative impacts. The decision about whether EPG is the right choice in a particular situation will depend not only on the nature and seriousness of the deterioration, but on the significance of the glass, the window, the building, and the setting.

In 2011, Historic England's Building Conservation and Research Team initiated the research reported here, with a fundamental aim: to establish whether EPG is robust enough to allow flexibility in design choices that could to minimise harm. In other words, how might modifications of the basic design of EPG affect its effectiveness?

Critical questions about EPG addressed by the research included:

- How should the space in between the panels of glazing best be ventilated?
- How wide does the gap between the original glass and the protective glazing (the interspace) have to be for EPG to function?
- What is the impact on effectiveness of leading and ferramenta, and other restrictions to air flow in the interspace?
- Should the interspace always be vented to the interior, or can ventilation to the exterior also be effective?

The research successfully answered all questions asked of it, and should help to inform conservators designing EPG systems.

It has also been used to develop guidelines to help those addressing environmental deterioration of stained glass, and considering EPG (see the 2018 Historic England guidance, [Stained Glass Windows: Dealing with Environmental Deterioration](#)).

The EPG Research Programme

The EPG research project was aimed at providing a better understanding of critical features of EPG systems (such as the depth of gap needed between the historic and new glazing, and the best way of ventilating that gap), so that design criteria could be understood and optimised. The methodology included:

- reviewing the current state of knowledge and practice in EPG
- studying in detail a large number of EPG installations, both new and old
- monitoring the environment in and around a number of *in-situ* EPG systems
- using the monitoring results to develop a calibrated Computational Fluid Dynamics (CFD) model
- using the CFD model to examine the impact of specific design details such as the size and shape of the vents, and the width of the gap.

A side interest of the research was the potential of EPG to reduce the energy expended on heating buildings with stained glass. Sealed secondary glazing systems are an effective way of decreasing heat transfer through windows, but condensation can be a serious risk. It was therefore of interest to examine exactly how much ventilation of the interspace might reduce the thermal efficiency of secondary glazing.

Summary of the Research Results

The research confirmed that both internally and externally ventilated EPG systems do indeed afford stained glass considerable protection from wind, rainfall and pollution. Almost all systems examined also significantly improved thermal buffering, reducing the risk of condensation on the internal surfaces.

In this regard internal ventilation was the most effective option, but externally ventilated systems still gave useful benefits.

The building environment does need to be in reasonable condition for EPG to completely prevent condensation damage to stained glass. Where defects in the envelope or the water-handling systems meant the background relative humidity was very high, EPG could not entirely prevent condensation events. It therefore cannot be seen as a way of avoiding the need to deal with problems of the building envelope.

The CFD results revealed how the different elements of EPG affect each other, and have helped us understand what an optimal configuration might look like. Even so, in practice every EPG system will need to be designed for the specific constraints of the particular building and window being treated. This must include close consideration of future maintenance demands.

The researchers also took the opportunity to examine the effect of EPG on heat loss through windows, a topic of increasing importance given the need to reduce the energy used to condition buildings. The results confirmed that EPG does reduce heat loss. It should be noted, however, that for most buildings with stained glass the ratio of window area to solid wall is so small that heat loss through the glass is unlikely to be a serious issue. Since the energy cost of the EPG system must also be taken into account, one would not consider installation for energy-loss reasons alone.

As part of the design of the EGP system, an important factor will be consideration of its aesthetic impact upon the building. Secondary glazing can easily have a very negative effect on the appreciation of stained glass from both inside and outside the building, and even more strongly on the appearance of the building itself. A balance must always be struck between conservation need and aesthetic impact: on the potential gains and losses for that particular window, in that particular case. By their nature most EPG systems are reversible, but they are expensive, and if they are necessary to protect stained glass from irreversible damage, then they should be designed with maximum sensitivity to aesthetics from the outset.

It is usually possible to overcome any technical and aesthetic problems by devoting sufficient time and care to design and planning. In most cases, this will mean testing full-scale mock-ups, since a design that has worked beautifully in one case may well neither function optimally nor look good in the next. Even different windows on the same building may well require different treatments.

In every case, however, it is essential that technical functionality be the primary design factor. If an EPG system cannot be made aesthetically acceptable without undermining its ability to protect the stained glass, then it should not be installed.

IMAGES

All images ©Tobit Curteis Associates unless otherwise stated.

ARCHIVE LOCATION

Swindon

DATE OF RESEARCH REPORT

March 2019

CONTACT DETAILS

email: Conservation@HistoricEngland.org.uk

CONTENTS

| | |
|----------------------------------------------------------|----|
| 1 INTRODUCTION | 1 |
| 2 HOW ENVIRONMENTAL PROTECTIVE GLAZING WORKS | 4 |
| 3 TYPES OF STAINED GLASS | 8 |
| 4 DETERIORATION OF STAINED GLASS..... | 9 |
| 4.1 Liquid Water | 12 |
| 4.2 Surface Washing | 13 |
| 4.3 Water Vapour | 13 |
| 4.4 Atmospheric Pollution | 14 |
| 4.5 Temperature | 15 |
| 4.6 Microbiological Attack..... | 16 |
| 5 THE LEAD MATRIX..... | 17 |
| 5.1 Deterioration of the Lead Matrix..... | 18 |
| 6 EARLY HISTORY OF PROTECTIVE GLAZING | 21 |
| 7 RECENT DESIGNS AND DEVELOPMENTS..... | 22 |
| 7.1 Types of Ventilation | 22 |
| 7.2 Rates of Ventilation | 24 |
| 7.3 Developments in Design and Geometry | 25 |
| 7.4 Local Heating..... | 26 |
| 7.5 Physical Protection and Other Window Coverings | 27 |
| 7.6 Interspace Drainage | 28 |
| 8 BUILDING ENVIRONMENT AND HEATING | 29 |

| | |
|------------------------------------------------------------------|-----------|
| 9 EFFECTS OF EPG ON HISTORIC GLAZING | 30 |
| 9.1 Weather Protection..... | 30 |
| 9.2 Condensation..... | 30 |
| 9.3 Water Vapour | 30 |
| 9.4 Temperature..... | 31 |
| 9.5 Biological Growth..... | 33 |
| 9.6 Pollutants and Particulates..... | 33 |
| 9.7 Rain Washing Effects | 33 |
| | |
| 10 MAINTENANCE OF EPG SYSTEMS..... | 34 |
| | |
| 11 ENVIRONMENTAL SURVEY AND MONITORING | 35 |
| 11.1 Glass Sensor (Dosimeter) Monitoring..... | 35 |
| 11.2 Environmental Monitoring..... | 36 |
| | |
| 12 CASE STUDIES | 39 |
| 12.1 The Vyne | 40 |
| 12.2 Canterbury Cathedral..... | 42 |
| 12.3 Long Melford..... | 44 |
| 12.4 Lincoln Cathedral | 46 |
| 12.5 St Mary and St Barlok's Church..... | 48 |
| 12.6 St Mary and St Barlok's Church..... | 50 |
| 12.7 King's College Chapel..... | 52 |
| | |
| 13 CFD MODELLING: PERFORMANCE AND ENERGY EFFICIENCY | 54 |
| 13.1 Tests..... | 54 |
| 13.2 Results..... | 59 |

| | | |
|------|--------------------------------------------------------------------|----|
| 14 | PROTECTIVE GLAZING AESTHETICS | 68 |
| 14.1 | Appearance of the External Layer | 68 |
| 14.2 | Respecting the Shape of the Stonework | 72 |
| 14.3 | Other Factors Affecting the Appearance of the External Layer | 73 |
| 14.4 | A Temporary Reversible Measure?..... | 78 |
| 15 | LIGHT TRANSMISSION..... | 79 |
| 16 | CONCLUSIONS..... | 80 |
| 17 | GLOSSARY | 83 |
| 18 | ENDNOTES | 87 |
| 19 | BIBLIOGRAPHY..... | 89 |

1 INTRODUCTION

Stained glass windows can often give the impression of permanence. Fields of colour commonly viewed from a distance appear to have survived the ravages of time almost untouched, despite the visible impact of ageing on other elements of the building.

In reality the situation is very different. Stained glass is fragile and vulnerable, both from mechanical damage and the effects of inappropriate restoration, as well as the chemical and environmental deterioration common to all materials used in historic buildings. Unlike some elements of architectural decoration, stained glass is also part of the building envelope. So a failure of the glazing represents not only a loss of the aesthetic integrity of the building but may also cause structural failure.

The repair and maintenance of stained glass has been taking place as long as the manufacture of stained glass itself. However, as glass deterioration has begun to be better understood, so the approaches to repair and conservation have developed. Since the 19th century, it has been recognised that, to maintain particularly vulnerable stained glass in situ within the windows, and to prevent further serious deterioration, protection using secondary glazing is often required. Systems of protective glazing have changed over time depending both on a greater understanding of the science behind how the system works and upon aesthetic fashions.

Although protective glazing systems have been commonly used in England throughout the 20th century, the way in which specific designs function and the benefits or otherwise of certain design details, remain little understood.



Figure 1: Stained glass can appear perfect from the ground.



Figure 2. Closer inspection reveals corrosion pits have damaged the red glass layer.

In its role as the statutory advisor on planning matters involving listed historic buildings, Historic England is regularly consulted as to the merits and justifications of environmental protective glazing systems, balanced against the aesthetic impact that such a system will inevitably have on the building. With little technical material available to building owners or to Historic England advisors, debate in specific cases can be limited and is often dominated by short term and subjective aesthetic concerns, rather than the working properties of a particular system, and the conservation impact it may have on a particular window.

With the general increase in concerns about carbon footprint and energy efficiency, the impact of protective glazing on the thermal insulation of historic buildings is also a matter of concern. Very little research has been undertaken in this field in contrast to the significant level of work which has been carried out with regard to more general energy efficiency in historic buildings. Therefore, the possible impacts of a protective glazing system applied for conservation reasons, on the energy efficiency of the building, is often little understood.

In order to provide a more informed context for such debates, the current study has been commissioned by the Building Conservation and Research Team at Historic England. The aim of the study is to draw together the current understanding of the effect of environmental protective glazing, through extensive literature review and consultation with practitioners, the implications of different designs and a set of protocols by which judgements can be made as to the advantages and disadvantages of a particular protective glazing installation.

The study includes a review of the deterioration processes of stained glass, the history of protective glazing and the effect of environmental protective glazing on controlling the underlying causes of glass deterioration. In addition, it addresses the question of the aesthetic impact of protective glazing systems, as well as the impact on thermal insulation and energy efficiency.

New research using computational fluid dynamics (CFD) modelling has been undertaken examining how specific design details of secondary glazing systems function, in particular interspace depth and vent geometry. In addition, certain key research documents, originally published in German, have been translated into English, to improve accessibility to the Anglophone audience.¹

It is intended that this report, and the publication and summary documents which are drawn from it, will be used to inform those building owners and conservation professionals involved in cases where protective glazing is being considered, with the hope that the debate can be well-informed and any intervention can be undertaken with a full understanding of the implications both in conservation terms, aesthetic impact and the effect on energy efficiency of the building as a whole. The documents are not intended as design manuals, which is the province of the professional stained-glass conservator, but rather as tools to allow use of protective glazing to be discussed in a particular case and, if it is found to be the appropriate conservation approach, to allow the design options to be evaluated.

In terms of nomenclature in this report, Environmental Protective Glazing (EPG) is used to denote the whole system while the term protective glazing or new glazing is used to denote the new, external glazing.²



Figure 3. Closer inspection shows black paint details are flaking inside. ©Léonie Seliger

2 HOW ENVIRONMENTAL PROTECTIVE GLAZING WORKS

The installation of EPG adds a new glazing panel to the outside of the historic glazing, leaving an air gap between the two, generally ventilated at the top and bottom of the panel, which increases thermal buffering between internal and external conditions. In periods when the external conditions are colder than those inside, this raises the minimum temperature of the historic glass, reducing the risk of condensation, which is transferred to the new glass now serving as the interface with the external environment.

A number of designs of protective glazing have been used since the approach was introduced in the 19th century. Most common today is the internally ventilated design sometimes referred to as isothermal glazing. In this design, the historic glass is moved inside the building, usually on a frame, with ventilation gaps at the top and bottom. The protective glazing is then placed in the original glazing grooves, allowing internal air to circulate between the two layers. In some instances, the historic glass remains in the original glazing grooves and the external protective glazing is secured outside. Individual sections of the historic glass are then moved forward to create ventilation gaps allowing the circulation of internal air. When the air in the interspace is warmer and more buoyant than the air in the building (which will occur when the external conditions are significantly warmer than the interior) the air will flow upwards drawing air in through the bottom vent and expelling air through the top vent. When the air in the interspace is cooler and less buoyant (as when external conditions are colder than internal) the opposite flow pattern will occur.

The performance of the EPG system can be compromised by poor design with thermal buffering being limited by factors including insufficient interspace depth or poor airflow resulting from restriction caused by stone tracery, historic ferramenta and modern metalwork supports, deformation of the historic glass panels or poorly designed and sized vents. The effectiveness of EPG can also be limited by poor environmental conditions within the building itself.

As the modern glazing will form the interface between internal and external conditions condensation will form on it in preference to the historic glazing. However, unlike the previous situation, when free air movement would allow evaporation of condensation from the historic glass, with EPG in place, the condensation now forms in a semi enclosed air space. Nevertheless, the condensation on the new glazing should evaporate quickly, as long as there is sufficient air flow through the interspace allowing it to be exchanged with dryer internal air.

Historically, systems with external ventilation were widely used and are still employed successfully in some applications today. Mixed internal/external vented systems and sealed systems have also been used in the past, as well as designs employing heating.

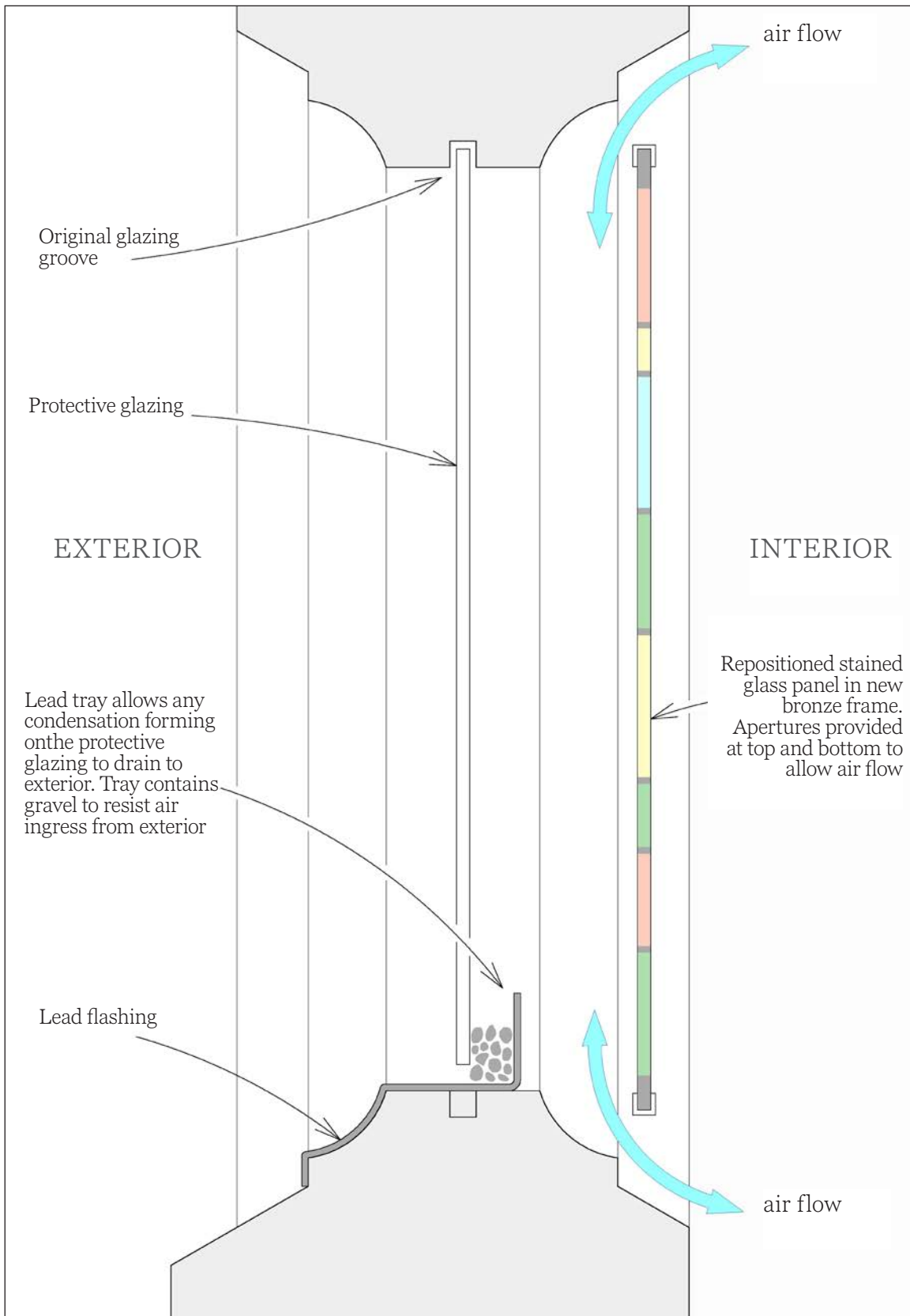
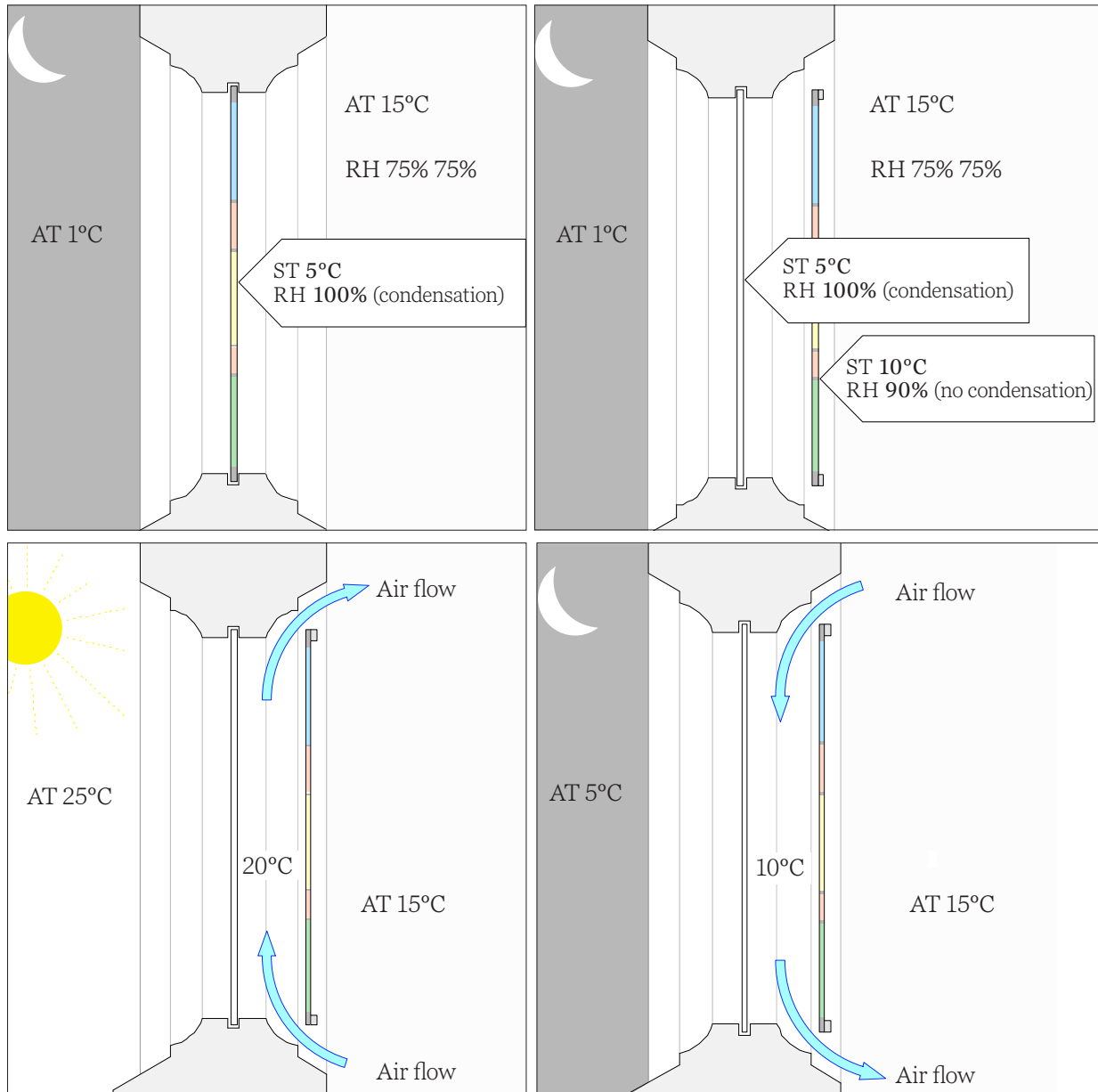

Figure 4. Schematic showing the functional elements of an internally-ventilated EPG system. The precise details of every installation will depend on the particular building, and the configuration of the window being protected.



Figures 5, 6. Schematics showing the environmental effects of internally ventilated EPG. The environmental values used for these diagrams are simplified to illustrate the principles. The actual values will vary within a single window, and will be dynamic (changing continually throughout the day and night).

Abbreviations:

- AT = ambient temperature
- RH = relative humidity
- ST = surface temperature



Figures 7, 8. Ventilation openings at the top and bottom of a recently installed internally vented system at the Vyne, Berkshire.

As well as modifying the microclimatic conditions to which the historic glass is exposed, EPG also prevents direct rainfall and wind loading from damaging or further corroding the external glass surface. If the EPG is ventilated to the outside there is a risk of some precipitation entering via the vents. In addition, outside air is generally more polluted than the internal air, and so external ventilation may not reduce the effect of pollutants on the external historic glass surface to the same extent as an internally vented system. However, as an externally ventilated system may require a lower level of intervention on the historic glazing itself, the overall risks and benefits of internal and external vented systems need to be carefully evaluated in each individual case.

3 TYPES OF STAINED GLASS

Glass is made by melting sand (SiO_2) with soda ash and limestone at very high temperatures (1700°C or more), which when it cools forms an amorphous (non-crystalline) solid. This can be transparent, but can be coloured by the addition of other metallic oxides.³ However, there are a number of other ways of producing coloured glass. Techniques include painting, staining, as well as etching or abrading coloured glass to create depth of tone or white areas. 'Flashed' glass is produced by fusing a thin coat of a very richly coloured glass, often red, onto clear glass during manufacture, to allow more light to pass through.

A range of painting techniques have been used including oxide (grisaille) paint where metal oxide pigments are mixed with a flux of low-temperature-melt, finely ground glass in water- or oil-based media, and fixed by firing. These layers can be very thin, as with carnation red (Sanguine), where the iron oxide contains very little lead oxide or glass. When applied to the external surface such thin layers are particularly vulnerable to weathering and abrasion. Enamels also form thin layers of coloured glass usually applied on the internal face. Enamels are formed by mixing metal salts with lead-rich glass powders in water or oil and firing to bond to the surface. Sometimes ordinary oil paints, so-called 'cold' paints, were applied to the glass surface without firing, so the bond between the paint layer and the glass is particularly weak.⁴

True staining of glass involves mixing metal salts into a clay that is applied to the glass surface and then fired. The metal ions migrate into the upper surface of the glass, changing it chemically to create a colour within the glass body itself. After firing the clay is washed away. Silver (or yellow) stain uses silver nitrate or silver sulphate to create yellow colours ranging from pale lemon, through to orange or brown. Copper stain has also been used to create red colours in the same way. As this stained glass technique does not form a separate colour layer applied on the surface, these colours are generally very robust.

4 DETERIORATION OF STAINED GLASS

The techniques used to colour the glass can lead to specific types of deterioration. For example, when the firing has been poor, grisaille paint can fail as the oxide layer is not well bonded to the base glass. Thin layers, such as carnation red can also be scratched or even cleaned off, as well as eroded by weathering. Enamels are vulnerable to differences in thermal responses between the coloured layer and the base glass, leading to cracks and delamination of the enamel layer. Cold paints are particularly vulnerable to delamination and flaking and so rarely survive. They can be lost as the oil binder has been degraded by high temperatures, UV light, or microbiological growth.



Figure 9. Flaking blue enamel on 18th-century glass. ©Léonie Seliger



Figure 10. Loss of grisaille details on 16th-century glass at The Vyne.

Clear glass, the manufacture of which has changed over time and location due to the availability of materials and understanding of glass technology, is also vulnerable to deterioration. Some medieval glass is known to be more unstable due to the use of plant ash, which creates glasses containing a very high proportion of alkalis such as potassium and calcium in addition to silica, rather than the more stable combination of sodium, calcium and silica.⁵ In these high alkali potassium-rich glasses, water (from rain or condensation) can leach alkali ions from the glass surface, replacing these with hydrogen ions from the water. The alkali ions can then react to form weathering crusts on the surface of the glass.⁶

For most of the deterioration processes, water is a key factor. The main sources of water are rainfall, relative humidity, marine aerosol, capillary moisture, condensation and bioactivity. Additional factors affecting the deleterious impact of moisture include gaseous pollutants and hygroscopic and deliquescent salts on the glass surface, which can prolong water contact.

Different water sources can cause different types and locations for deterioration. For instance, liquid water can arise from both external (rainfall) and internal (condensation) sources. However, external wetting will generally cause the body of the glass to deteriorate; whereas internally it is often the paint layer that is damaged. So, for example, using glass sensors at Gloucester Cathedral, greater corrosion was recorded internally, presumed to be due to condensation, compared to external conditions. This emphasizes the effect of the building environment as well as the external weather on glass deterioration.

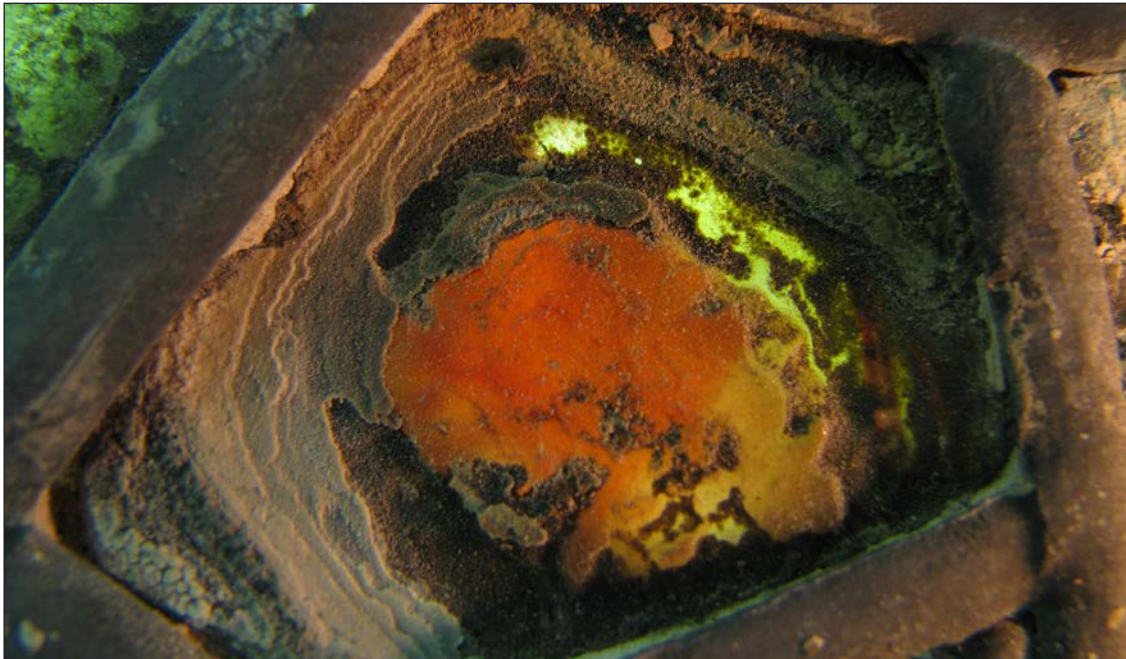

Figure 11. Weathering crust on the external surface of glass at Canterbury Cathedral.

©Léonie Seliger

Figure 12. Weathering crust at Milton Manor. ©Léonie Seliger

4.1 Liquid Water

A characteristic deterioration process in historic glass occurs as a result of the leaching of soluble ions, including potassium, sodium, calcium or magnesium.

The leaching reaction happens with most glass compositions, but in durable glasses the leached layer forms a barrier, slowing and then preventing further leaching, as the water cannot reach the bulk glass behind. In low durability glasses, such as high alkali potassium glasses, the leached layer forms cracks, creating a crizzled surface. These cracks allow water to continue to penetrate beneath the glass surface, effectively continuing the leaching processes.⁷



In alkaline solutions (pH>9) the leaching reaction slows and the corrosion of the glass matrix involving the break down of the silica network of the glass body, is more prevalent. In highly alkaline situations, a further reaction can occur reforming the silica network in the glass and increasing the water content of the gel layer (the vulnerable surface layer of the body glass), which can lead to further leaching reactions taking place. The corrosion process often begins at single points, where leaching of the glass has already formed localised alkaline solutions, leading to pits on the surface.

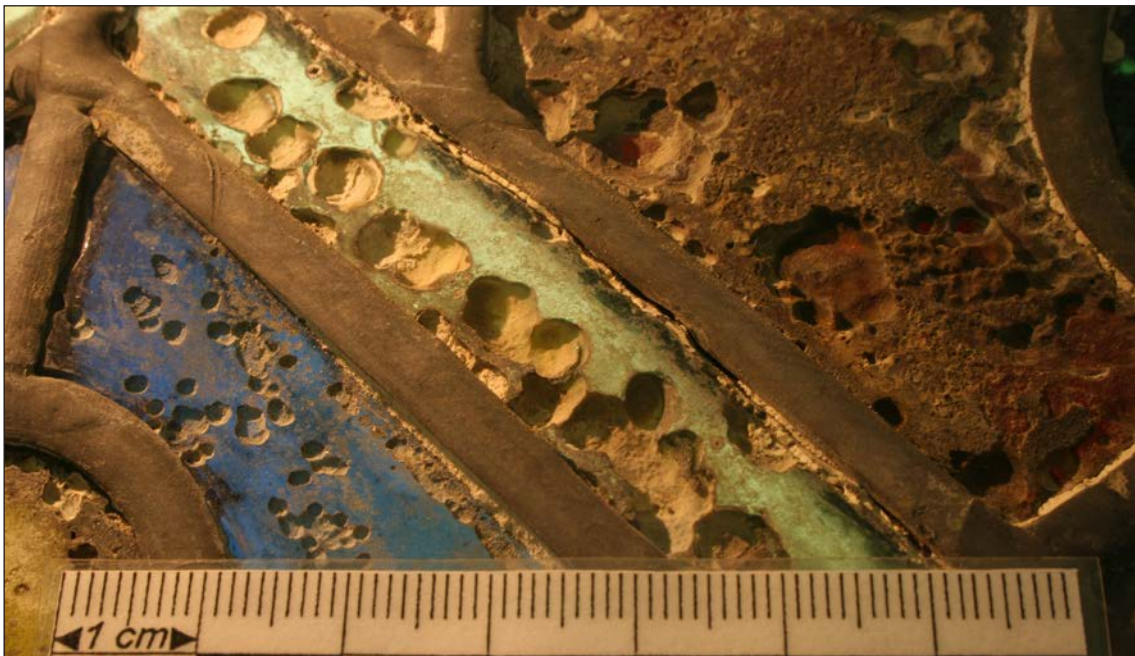

Figure 13. Pitting at St Mary and St Barlock's Church, Norbury, Derbyshire.

Figure 14. Pitting on the external face of glass at Canterbury Cathedral. ©Léonie Seliger

4.2 Surface Washing

The effect of rainwater washing away the surface deterioration products, rather than leaving them on the glass surface has also been studied. The specific issue is whether, despite the deterioration associated with liquid water, discussed above, rainwater washing in fact helps reduce glass deterioration by removing the alkali species, therefore preventing increases in pH on the surface. Published data demonstrates that permanent weathering was observed on the unwashed sample compared to the sample that had been periodically washed. However, for low-durability glasses the results are similar regardless of washing. This suggests for stained glass the effects of washing are generally less important as similar weathering would be expected with or without washing.

4.3 Water Vapour

Historic glass remains vulnerable to the effects of water vapour, even when liquid water is not present. Experiments by Walters and Adams observed increases in the amount of sodium washed from the glass surface on test glass samples (assumed to have been leached from the glass body) even at relatively low RH levels (30% RH).⁸ The amount of alkali formed increased with increasing RH, with a rapid rise seen above 50% RH. Longer weathering periods also led to greater alkali generation. Similar findings were reported by Cummings et al where the depth of hydration in the glass (the leached layer) rose with increasing RH. In this case liquid water was also included and led to greater glass deterioration than high levels of RH (80%) alone. The same authors tested the effects of increasing temperatures and found higher values also led to thicker hydration layers.⁹

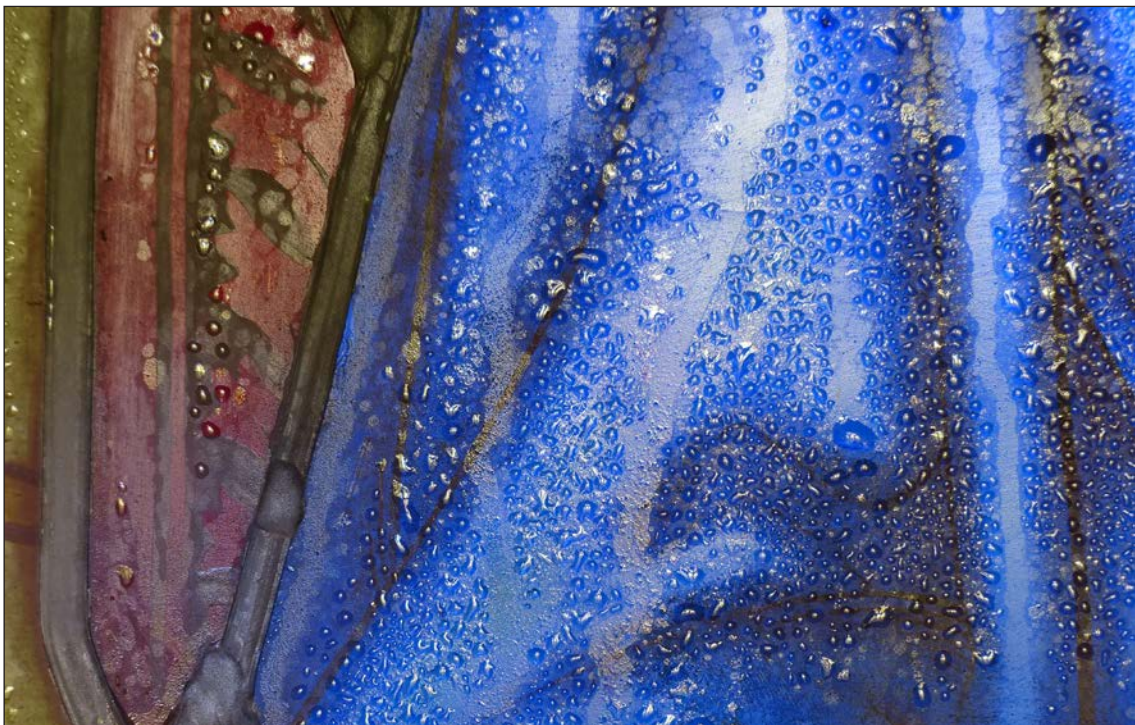

Figure 15. Condensation on the internal glass surface.

Walters and Adams compared the effect of static conditions at high RH (98%) with those of cycling conditions (between 77-98% RH) To determine whether it is better to have the surface condensation remain for long periods of time (static high RH) and a single drying event, or to have a number of condensation and drying events (cycling RH). This found that for a range of glass types the deterioration was greater under static conditions, i.e. long condensation events. In some cases cycling conditions created a similar level of deterioration but the results did not exceed those of the static test for the same material. However, this study did not look at the effects of salts and other contaminants which might undergo phase change and dimensional response during wetting and drying phases, leading to other deterioration processes.¹⁰

4.4 Atmospheric Pollution

The deleterious effects of pollution on stained glass, particularly in urban areas with high contamination levels, has been observed in very many cases. Laboratory tests comparing the effects of common external pollutants with clean, but moist air, found the presence of pollutants increased the depth of hydration. However there was little variation depending on the type of pollutant tested (NO_2 or SO_2) or whether both were used together. The hydration layer thickness is reported to be inversely proportional to the hydration rate squared. As a result, a factor of 3 increase in the hydration rate due to pollutants, leads to a factor of 9 decrease in the length of time it takes for the corrosion to progress to the same hydration thickness. The authors conclude that “this means that damage that would have taken 250 years to occur in a clean (pollution free) environment would instead occur in 25 years”.¹¹ This correlates well with anecdotal evidence of rapid stained glass deterioration during the first half of the 20th century. However, the same authors report a factor of 10 increase in the corrosion rate with increasing RH levels (from 15% to 100%), which would lead to a factor of 100 decrease in the length of time to reach the same hydration thickness, 8 or 2.5 years using the above example.



Figure 16. Pollutants accumulating on the external surface of historic glazing at Lincoln Cathedral.

Other authors have used modern, potassium-rich glass samples, exposed in real locations across Europe to study the effects of pollution.⁷ Woisetschläger et al. found that samples exposed at more polluted sites (especially with higher levels of SO₂) were more corroded than those exposed at locations with lower pollution levels. Statistical analysis by Melcher and Schreiner found NO₂ and temperature were the most significant contributions, with SO₂ and RH having a more minor role. This work focussed on sheltered samples therefore the effects of liquid water from rain was not included. In Europe SO₂ levels have fallen significantly since the second half of the 20th century and so may no longer have the impact of previous high concentrations. A similar observation is made by Ionescu et al. with future, lower levels of pollution leading to less deterioration via this route.¹²

4.5 Temperature

Possible deleterious effects of high and fluctuating temperatures, particularly common for south facing windows, has long been a matter of concern and has been the subject of a number of studies. In most research the greatest amount of deterioration was reported as a result of water and pollution, with smaller influences from temperature. The limited tests to study thermal effects focussed on samples of glass with black grisaille decorative details.¹³ In historic stained glass windows these details were reported to be missing or flaking. This was due to microfractures in the black glass paint, which propagate into the material beneath, leading to the detachment of the paint layer. Similar damage has been reported for some enamel painted glass,¹⁴ but research has focussed on the enamel composition rather than the causes of the cracking.¹⁵

Becherini et al found differences in the thermal expansion of the bulk glass and the black grisaille layer led to stress forming between the two layers, which increased upon cooling. When large and rapid thermal shocks (temperature changes of 40°C or more, occurring in 2 minutes or less) were applied to test materials, cracks rapidly appeared. The propagation of these cracks leads to the loss of the black grisaille details. The authors suggested the size of the thermal shocks used in their experiments are unlikely to be seen on real windows, but observe that repeated smaller shocks over longer time periods may bring about the same effect. Studies on south facing windows at a number of sites in the UK, including Canterbury Cathedral, have shown that surface temperature fluctuations of greater than 40°C are not uncommon, but that they generally take place over a number of hours rather than in minutes.

4.6 Microbiological Attack

Microbiological growth occurs as a result of condensation on glass or high levels of liquid water, generally, but not always, on the internal surface, especially where there is sufficient dirt build up to provide a source of nutrients. Microorganisms produce acids, which can etch the glass not only affecting the translucency of the glass but also creating further cracking in the hydration layer. Additionally, acid deposits can crystallise on the surface and are difficult to remove. Microbiological growth also holds water at the surface of the glass, further facilitating glass leaching and corrosion reactions.



Figures 17, 18. Microbiological attack is both unsightly and can cause chemical deterioration of the glass as well as retaining moisture. Damage can occur internally as at Norbury in Derbyshire (top) or externally as at Boughton Aluph in Kent (bottom, ©Léonie Seliger).

5 THE LEAD MATRIX

Lead is an integral part of almost every stained glass window forming the matrix within which the individual glass pieces are held. As well as a structural component it is often an important artistic element in the appearance of the glazing.

Medieval lead was cast into moulds and often trimmed with a knife to fettle away the 'flashing', the excess material at the seam between the two mould halves. It was usually very narrow (<4mm–c.6mm wide) and had a flat or bevelled convex flange.

From the mid-16th century, lead mills came into use. These allowed the production of longer continuous lengths of lead comes. Flat, beaded, and rounded (convex) flanges were produced. To facilitate the transport of the rough casts, the wheels of the mill were scored or toothed. This tooling left a mark on the heart of the lead, and in some cases, particularly in the 18th century, lead come makers inscribed the wheels with initials, names, and even dates. The spacing and type of milling marks changed over time and from maker to maker. Since lead mill parts can last for several decades, the marks can be used only as a rough *terminus post quem*.

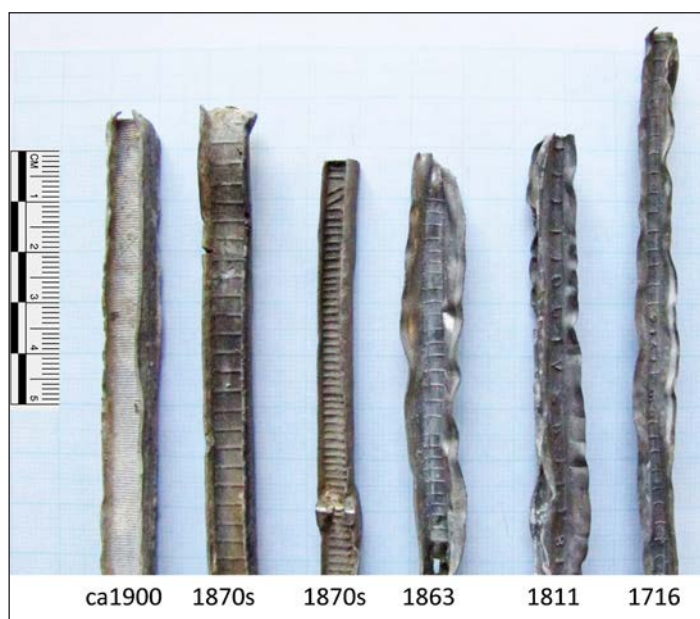

Even though lead types and milling marks may only give date ranges, this information can be invaluable archaeological evidence for dating the glazing of a window, and indeed for dating a repair or alteration.



Figures 19, 20. Details of historic lead comes showing milling and makers marks.

©Léonie Seliger

5.1 Deterioration of the Lead Matrix

In normal environmental conditions lead will develop a comparatively stable surface patination of lead oxides, lead carbonates and hydro-carbonates and lead sulphates which can provide a level of chemical protection. However, more severe corrosion can occur in industrially polluted or marine environments, or when acids are present (e.g. off-gassing from green oak frames).¹⁶

Fractures across the lead flanges are a sign of metal fatigue. They often occur close to solder joints, indicating that the large temperature fluctuations involved in the soldering process cause a weak zone in the body of the lead profile. Strain resulting from different rigidity and expansion coefficients of lead profile and lead-tin solder joints probably also play a role, but fractures can occur at other places in the lead matrix that are not associated with solder joints. Fractures have been observed in lead of all ages, indicating that the composition of the lead (the trace elements present) is a factor in their development.

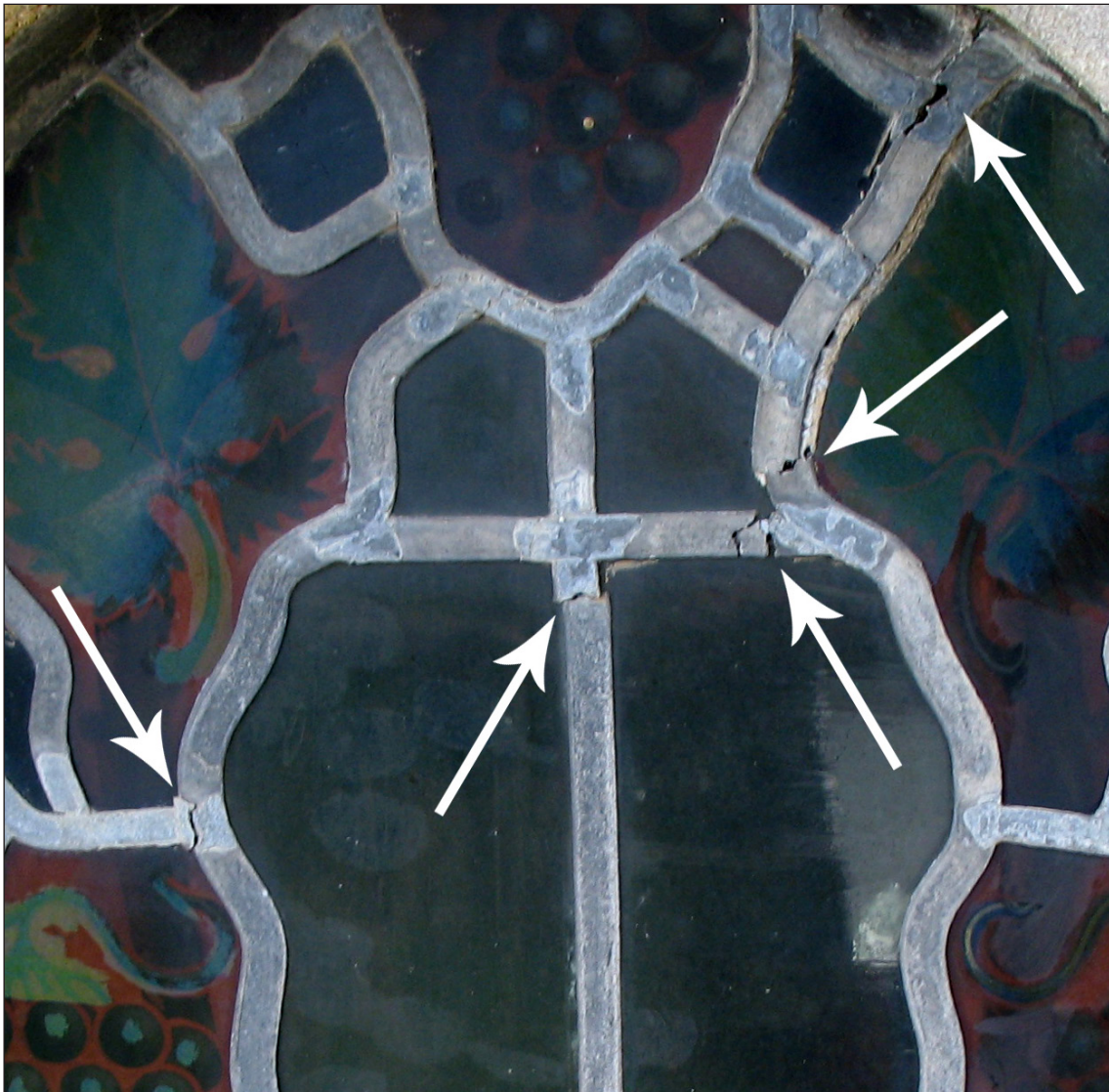

Figure 21. Fracturing of lead comes at vulnerable junctions. ©Léonie Seliger

Embrittlement of the lead profile is another phenomenon which can seriously weaken the structural integrity of the glazing. It is most likely associated with poor composition of the lead in combination with repeated heating and cooling.

Bowing panels are a common sight, particularly (but not exclusively) on windows facing in a southerly direction. The causes are not well studied, but are likely to result from the dimensional response of the lead came associated with thermal expansion and contraction and wind loading. The extent of the deterioration may vary depending on the design of the window and the amount of came within the structure, the sectional profile of the lead, the level of exposure to solar gain as well as to wind loading. Anecdotal reports indicate that windows with darker colours have a tendency to heat and distort more than those with lighter colouring.

In rural areas, reddish-brown dioxide discolouration have been observed to develop on lead came as on lead roofs and garden sculpture. The precise cause of the reaction in different locations is not fully understood but is thought to be associated with atmospheric pollution, local pollution such as bird droppings and sunlight exposure. This discolouration is unsightly, but does not appear to cause structural problems.

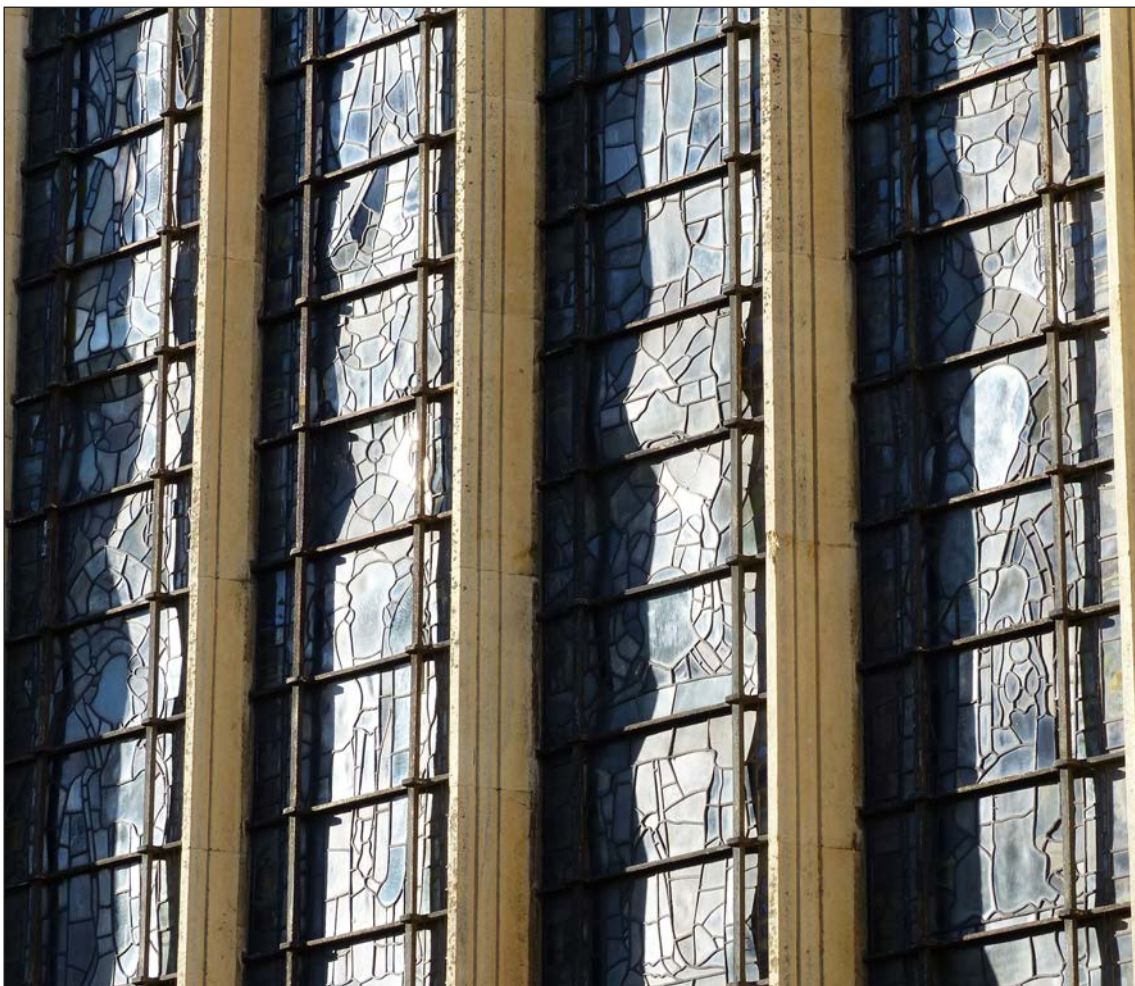

Figure 22. Distortion of the glazing plane as a result of expansion and contraction of the lead came.



Figure 23. Superficial corrosion and discolouration of the lead came. ©Léonie Seliger

5.1.1 Conservation and restoration of lead matrices

Until fairly recently, the conservation/restoration of historic stained glass almost always involved almost replacement of the lead matrix. It was assumed that window lead had a life span of 50–100 years, and that it should be routinely replaced.

While it is possible that relatively young windows may require re-leading due to one of the failures described above, it certainly does not apply to all. However, much historic lead was lost because of this approach, including most lead dating to the medieval period.

Often, narrow and/or thin-walled profiles were replaced with much wider and/or thick-walled profiles. This made a visual change to the window, and also created a greater chance of bowing of the panels. Dismantling and re-leading a window causes stresses and strains that should be avoided and there is an increased risk of glass fractures and damages to fragile painted decoration. Indeed in many cases, there is no reason to interfere with an old lead matrix if it is structurally sound.

Where historic lead matrices are bowing, they can often be flattened and re-grouted and the resulting improvement in structural support may reduce the chance of future bowing without the need for EPG or other interventions. However, where the lead is too weakened to withstand high wind forces, EPG very often enables the retention of lead matrices that are still strong enough to provide a reliable framework for the glass. With support via saddle bars etc., embrittled and thin-walled ancient lead can be retained. Fractures can be re-soldered, using where necessary copper gauze within the solder joint to provide additional strength. In this way, the integrity of the historic glazing can be retained as one object with all its various parts intact.

6 EARLY HISTORY OF PROTECTIVE GLAZING

Protective glazing is recorded to have been used from the beginning of the 19th century. Barley cites the earliest example of protective glazing as 1804, for the east window at Tattershall Church, Lincolnshire. In Lindena Church in Germany, secondary glazing is recorded as having been applied in 1896 while in England, secondary glazing was added to the Five Sisters and Great East Windows at York Minster in 1861-2.^{17,18} In the UK it was common to ventilate protective glazing systems to the outside until the mid-1970's when members of the York Glaziers Trust visited European sites, where internally ventilated protective glazing was more common.

One of the most important early examples of the protective effect provided by secondary glazing in the literature is from Berne Minster in Switzerland. Following the Second World War the stained glass in the main lights had internally ventilated protective glazing applied. However, the head and tracery sections remained unprotected. Barley reports that differences in condition had been noticed as early as the 1960's between the protected and unprotected sections. The difference in the level of deterioration between sections of glass of the same colour, was reported to be striking by 1988.¹⁹ The unprotected parts were reported to have a fine dense pitting mostly on the inside. A further example of protective glazing, dating from the same period at Königsfelden, was also reported to be beneficial although this relied on comparison with photographs dating from the installation.

7 RECENT DESIGNS AND DEVELOPMENTS

The design of specific details of an EPG system can have a very significant effect on its functional performance.

7.1 Types of Ventilation

As alluded to above, protective glazing can be ventilated to the outside, to the inside, or in some rare examples unventilated or, indeed, ventilated in both directions.²⁰ Trumpler reported on a stained glass panel that had been ‘sandwiched’ between two glass panes, leading to “numerous new cracks and a frightening flaking of the backside-enamel” after 15 years.²¹ Femenella and Simon went further suggesting that “All studies indicate that not venting the interspace results in increased levels of glass corrosion.”²² Unventilated protective glazing is less common, although some examples are known in continental Europe.

Although externally ventilated protective glazing is sometimes used in the UK, it is rarely, now, the preferred approach. One reason for this is the external air was commonly more polluted than the internal air, although, with the exception of some urban settings, this is now less of an issue. The external vents risk allowing rainwater to enter the interspace. Examples of such intrusion with resulting localised corrosion of historic glass were found on the Great South Window of Canterbury Cathedral. Newton has previously reported that external ventilation led to colder temperatures on the stained glass than for internal ventilation,²³ which would increase the risk of internal condensation. In the US external ventilation was recommended by Gilberg for hot and humid conditions, despite the use of air-conditioning inside, as the costs of altering the stained glass were seen as too high and any condensation that forms is likely to readily evaporate.²⁴



Figure 24. Ventilation openings at the bottom of an externally vented system installed in 1979 at Canterbury Cathedral.



Figure 25. Ventilation openings at the top of an externally vented system installed in 1979 at Canterbury Cathedral.



Figure 26. Internal ventilation openings at the bottom of the east window of St Andrew's Church, Trent, in Dorset.



Figure 27. Internal ventilation openings at the top of the east window of St Andrew's Church, Trent, in Dorset.

Most authors and conservators now consider internally ventilated systems as the optimal approach to protecting vulnerable stained glass windows. As Bacher noted in 1980, corrosion is markedly less on the internal face of the glass, compared to the external, so moving the window inside and mounting external protective glass, is favourable as it ensures better environmental conditions and a longer life expectancy.²⁵ The use of internal ventilation has the advantage of introducing air at the same temperature as the inside of the building, reducing the likelihood of condensation forming on the stained glass.

7.2 Rates of Ventilation

Air movement through the interspace relies on differential buoyancy between the air in the interspace and that in the supply space (the internal room for internally ventilated systems and the exterior for externally ventilated systems). The variation in buoyancy is largely a function of temperature so that as warm air in the interspace (heated by, for example, solar gain) rises it is replaced by cooler air at the bottom. If temperatures are very low outside, then the air in the interspace could be cooled and the direction of flow would reverse.²⁶ Early computational fluid dynamic research (CFD) found the temperature of the stained glass was closer to the internal ambient (i.e. better buffered from the exterior) if the air velocities were higher. Larger ventilation gaps have also been found to increase the air speed inside the interspace, which additionally reduced the RH levels.

Patronis reported that whilst increasing the air change rate in the interspace had minimal effects on condensation events occurring on the protective glass, it dramatically decreased the resulting moisture build-up.²⁷ This indicates that higher air flow rates in the interspace will increase the evaporation rate of any condensation.

7.3 Developments in Design and Geometry

Whilst most of the studies report the size of the windows and interspace depth, the ventilation gap size and vent positions are often less clear. In addition, due to the large number of variables between each studied installation of protective glazing, few authors have attempted to address the effects of changing the construction parameters upon the performance of the protective glazing. Bettembourg reported that from theoretical calculations the ventilation gaps should be the same size at the top and the bottom. It was also noted that a greater interspace depth required an increase in the ventilation gap heights, which seem to be illustrated as located on the front face of the stained glass. Finally, the author observed that the efficiency of the protective glazing depends more on the size of the ventilation gaps than the interspace size.²⁸

In the VIDRIO research project the protective glazing in Saint Urbain Basilica in Troyes often performed worse than installations in Paris or Cologne. This was reported to be due to the smaller interspace of 3 cm, compared with 7 cm and 8 cm in Paris and Cologne, respectively. In addition in Troyes there were a large number of ferramenta, which are reported to reduce the interspace to 1 cm in parts, limiting air flow. The windows in Cologne were north facing and this also affected the results in some cases.

Oidtmann et al. comment that enlarging the ventilation openings reduced condensation at Cologne Cathedral.²⁹ In addition the authors note that whilst condensation decreases as the ventilation gaps are widened from 0.5 cm to 2 cm, there is only a small improvement upon furthering increasing the width to 4 cm. Therefore, whilst many authors comment on the importance of the ventilation gap and interspace size, there is little firm guidance on what makes the best or most efficient sizes when designing a protective glazing system.



Figure 28. Interspace gap (before the reinstallation of the historic glazing).

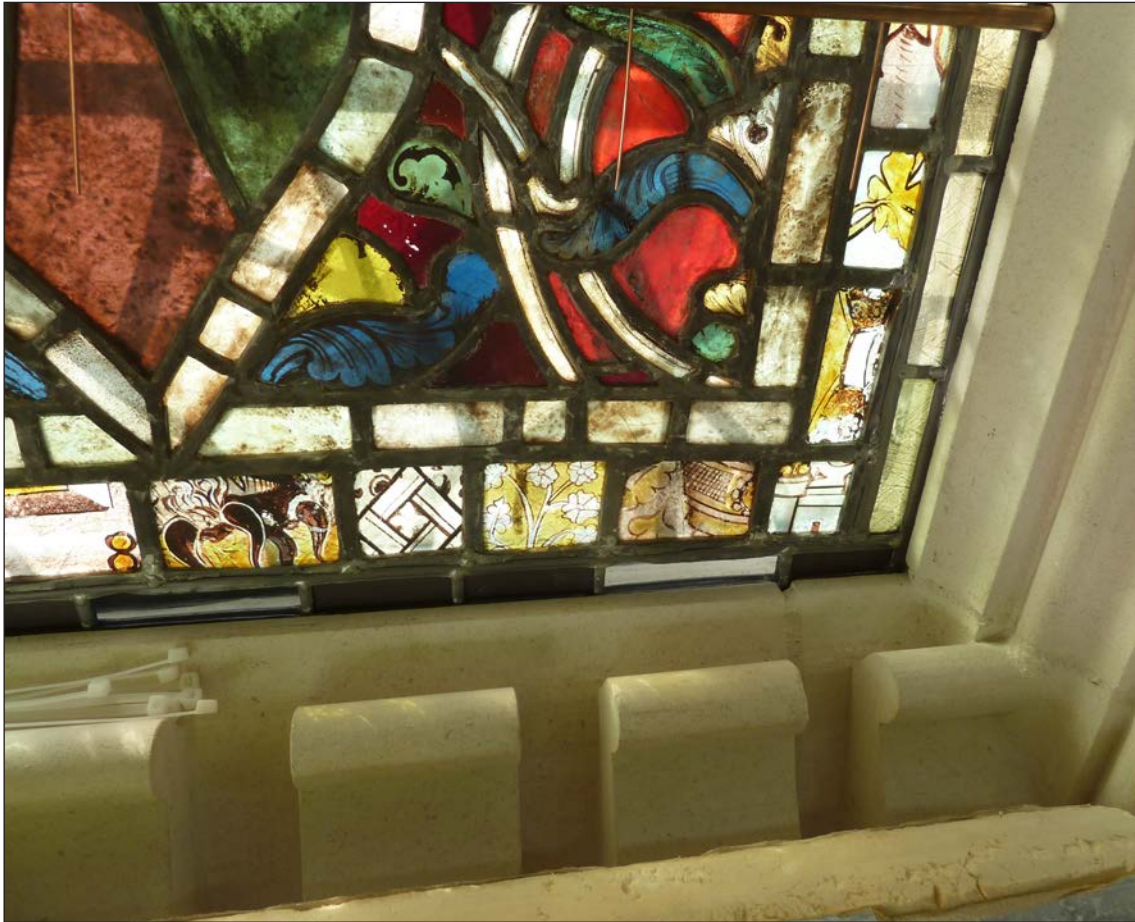

Figure 29. Ventilation openings at the base of the Great South Window at Canterbury Cathedral.

7.4 Local Heating

It has been postulated that condensation could be reduced by locally heating the stained-glass panel, the idea being to create a constant temperature on the glass. This is reported to have been tested in an experiment using heating wires in the interspace, however the outcomes are unknown.³⁰ A later test at Augsburg Cathedral found slightly lower levels of moisture in the heated interspace, however the authors comment that it is difficult to draw conclusions from this single test.³¹

The idea of providing heat at the base of unprotected historic glass in order both to heat the surface and provide a vertical airflow has also been considered and is known to have been used in some cases. While no formal study is known to have been carried out the energy levels needed to increase the temperature of the glass to a height for more than one or two meters, or to produce a mechanically induced buoyant airflow with greater effect than the naturally occurring downwards flow of dense cold air would be very high. Not only is this likely to be impractical on a window of any size, but the very high temperatures required at the base of the window may in fact be a risk to both glass and masonry, particularly if moisture were to be present.

7.5 Physical Protection and Other Window Coverings



Glazed windows are at the greatest risk from impact, including stones or bricks thrown by vandals. This has led to the use of external metal wire guards or clear panels of safety glass or polycarbonate to reduce the risk of breakages. Whilst these systems can protect against impact, they offer little environmental protection, so vulnerable glass will continue to deteriorate. In addition these measures can also have a significant aesthetic impact, discussed below. The earliest use of such protection is not readily identifiable, but by the 19th century the use of metal grilles was commonplace.



Figure 30 (top). New metal mesh guard.

Figure 31 (bottom left). Old deteriorated guard.

Figure 32 (bottom right). Temporary polycarbonate protection.

7.6 Interspace Drainage

As with unprotected windows, even in the best designed EPG systems, condensation is likely to form on the protective glazing, some of which will not evaporate and will run down the glass to the base of the interspace. In order to avoid saturating the masonry at the base of the window and encouraging damaging salt activity, it is necessary that an efficient system of interspace drainage is designed. This not only needs to be immediately functional, but also simple to maintain, so that it will continue to work in the future.

Many designs have been tested, the most simple of which involve small drainage holes from the interspace to the exterior. However, these are easily blocked, allowing the collected water to soak into the stone. A more effective system, that is simpler to maintain, is based on a lead-lined channel with drainage openings to the exterior. Condensation from the internal face runs into this and can both drain away through the openings and/or slowly evaporate to the exterior. The channel can be filled with graded gravel, which both reduces the risk of external air ingress (this can disrupt the internal ventilation of the interspace), and minimises evaporation back into the interspace.

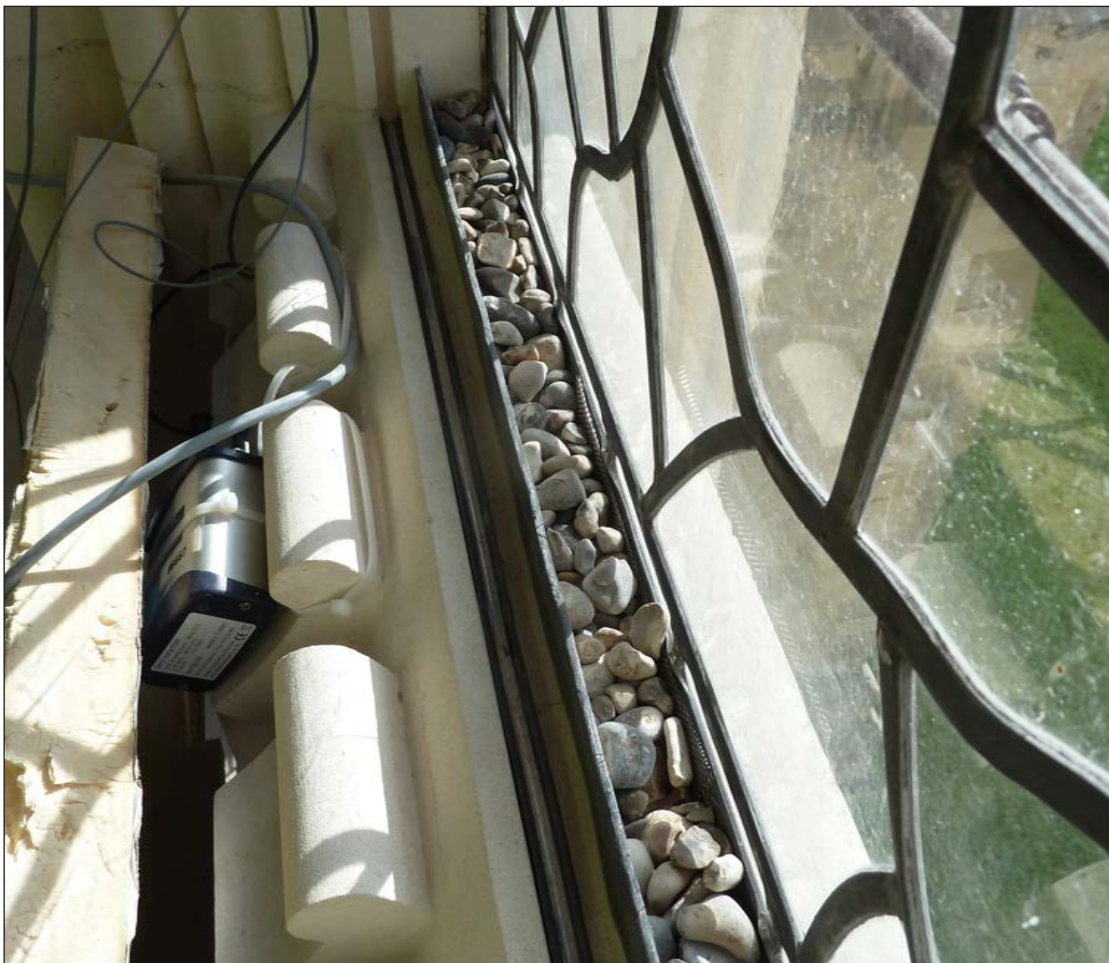

Figure 33. Interspace drainage in the Great South Window at Canterbury Cathedral (before the reinstatement of the historic glazing).

8 BUILDING ENVIRONMENT AND HEATING

The internal surface of the historic glass is exposed to the microclimate within the building and the basic source of damage caused by high humidity or condensation is within that internal air mass. Therefore, understanding and controlling the microclimate within the building is fundamental to the control of deterioration of the stained glass as well as to the performance of a protective glazing system. It is by no means an exaggeration to say that the condition of the masonry and pointing or of the rainwater disposal system are significant factors in the conservation of stained glass. Artificial influences such as heating and building use are also significant as they have a direct effect on the microclimate. However, historically, the focus on the whole building environment as part of the conservation of stained glass has been limited.

In the studies which have been undertaken, some differences have been reported depending on whether or not a church is heated. Newton reported significant differences between the stained glass surface temperature and the ambient room conditions when the building was heated, compared to unheated buildings when the glass was much closer to the ambient temperature.³² Computer modelling determined that for internally ventilated protective glazing the RH was above 60% (close to the windows) for less time in heated buildings compared to unheated buildings.³³ In the case of externally ventilated systems the presence of heating had less effect in reducing periods of high RH close to the windows.

The impact of building environment including heating and building use on the effectiveness of protective glazing has been examined by the author in more than 20 church and cathedral sites since the early 2000s and the results have demonstrated that the influence can be significant. While in most reasonably maintained churches the effects have had only limited influence on the performance of the EPG systems, the poor conditions in two of the case studies, St Mary and St Barlok's Church, Norbury and St Michael's Church, Princetown, and in particular the high RH due to liquid water ingress into the fabric, undermined the performance of the system significantly.³⁴ This reinforced the conclusion that the overall environmental performance of the building should be regarded as a critical design parameter for any EPG system.

9 EFFECTS OF EPG ON HISTORIC GLAZING

9.1 Weather Protection

Placing an external barrier in the form of protective glazing in front of the stained glass prevents the direct effects of wind and rain. In addition by internally ventilating the protective glazing the impact of polluted external air on the stained glass is limited. European studies found that weathering rates of the stained glass external face were reduced to those of the internal face, by the addition of protective glazing.³⁵

9.2 Condensation

Monitoring of the effects of protective glazing on numerous sites in the UK has shown that internally ventilated systems consistently and significantly reduce the risk of condensation on the historic glass. Data from Canterbury Cathedral showed the internally ventilated Corona Chapel window remained at least 6°C above the dew-point, whereas the externally ventilated window was around 2.5°C above the dew-point and the unprotected window around 2°C above the dew-point.³⁶ This indicates that the internally ventilated window was least likely to experience condensation, although it should be noted these measurements were taken in July. Monitoring of European protective glazing found that condensation was not always completely eliminated by the protective glazing, a finding consistent with that of the current author.³⁷ However, the number of hours of condensation was reduced significantly. As constant surface wetness and condensation both affect glass deterioration, reducing their frequency and duration with protective glazing will preserve the stained glass.

It was also reported that the annual average temperatures for protected historic glass were higher than for the new protective glass.³⁸ However this is not a result of summer temperatures, but rather winter ones, with the stained glass being maintained at a higher temperature due to its internal position compared to the protective glazing. These higher winter temperatures help prevent condensation from occurring. This result is also discussed in the case study section.

9.3 Water Vapour

In tests on European protective glazing, the RH close to the inside of the protected window was lower than for the unprotected window, especially at high RH levels.³⁹ In addition Bernardi et al. reported that the higher RH values were short lived for the protected window.⁴⁰ These effects are likely to arise due to the warmer temperatures of the protected stained glass, creating more favourable, localised microclimates. Lower RH levels are generally beneficial in reducing the rate of glass deterioration and reduce the risk of condensation occurring, demonstrating the protection recorded in the literature as a result of secondary glazing.

9.4 Temperature

Some authors have expressed concern that high summer temperatures, arising from direct solar radiation, may lead to a possible 'greenhouse effect' within the protective glazing. Work by Femenella and Simon studied this in great detail, however their calculations are for unvented windows and therefore less applicable to real examples of protective glazing.

Studies on south facing windows by Bernardi et al measured high temperatures for shorter periods on the protected historic glass compared to unprotected glass.⁴¹ Their results showed that the unprotected glass was subjected to more rapid temperature changes, both in terms of frequency and intensity, than the protected glass. The authors suggest that glass deterioration due to thermal shocks and heating events will be reduced by the addition of protective glazing.

These results prompted a series of detailed studies at on the 12th-century South Oculus at Canterbury Cathedral, a south facing window set high on the south west transept. The data indicated that the use of internally ventilated protective glazing did not in fact increase temperature over the unprotected control glass, due to the interrelationship between temperature and the speed of air flow. In other words as the temperature increased, so did the buoyancy of the air increasing air flow and speed, thus cooling the historic glass and countering cumulative heating. Some energy was also lost to the protective glass itself with the result that the data showed a slight decrease in temperature on the historic glass, although this was within the accuracy of the sensors.⁴²

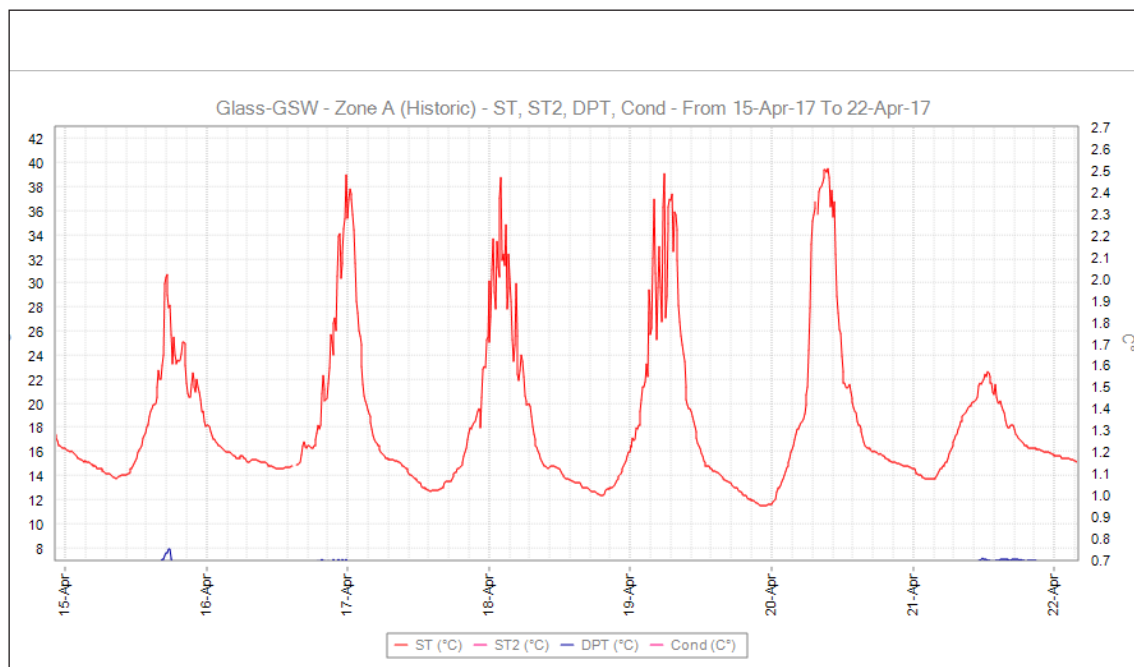

Figure 34. Surface temperature on the historic (protected) glass on the Great South Window at Canterbury Cathedral.



Figures 35, 36, 37. Microbiological growth can be both aesthetically disruptive and physically damaging.(all ©Léonie Seliger)

9.5 Biological Growth

Whilst there have been few studies on the effects of microbiological attack on stained glass, Bernardi et al record that microbial activity on protected stained glass is similar to levels on the unprotected internal face.⁴³

However, studies by the present authors have shown that the reduction in condensation and the lower boundary RH levels has had a direct limiting effect on the level and extent of microbiological growth. However, as the functionality of protective glazing is significantly influenced by the internal microclimate in the building, this should also be regarded as direct factor in which way in which microbiological growth occurs on stained glass.

9.6 Pollutants and Particulates

The European research project VIDRIO produced a number of papers on the effects of protective glazing in reducing pollution effects on stained glass.⁴⁴ This research measured lower levels of SO₂ and O₃ inside the building, and in the interspace between the stained glass and the secondary glazing, compared to external results.⁴⁵ However, NO₂ levels were similar internally and externally, and therefore also in the interspace. In comparison to the reduction in gaseous pollutants, particulate levels were found to be relatively similar inside the interspace at Troyes,⁴⁶ but lower in Cologne.⁴⁷ In general, the soiling and dust accumulation levels in the interspace were reported to be similar to internal room deposition levels.

9.7 Rain Washing Effects

One concern in the literature in regards to protective glazing is the loss of the washing effects as rainwater no longer cleans the glass surface and removes pollutants and particulates. In the glass deterioration studies, washing was found to be less critical for low-durability glasses, of similar composition to potassium-rich medieval stained glass. In addition deposition of pollutants and particulates is reduced by the use of internally ventilated protective glazing.⁴⁸ As a result, the loss of washing is a small risk, compared to the benefits of removing the rainwater that causes glass leaching and corrosion reactions.

10 MAINTENANCE OF EPG SYSTEMS

As with all other elements of windows and glazing, EPG systems need to be effectively maintained and this needs to be integrated into the design. An inspection of stained glass in an EPG system should be part of any quinquennial inspection.

Routine maintenance should include checking that the air vents are not blocked by dust deposits or other accretions, and that the drainage of the condensation trays is flowing freely. Flower arrangements and other ornaments on the window sills must be discouraged, as they may block the ventilation vents and impede air flow.

Experience at Canterbury Cathedral has shown surprisingly little dust deposits and insect activity in the interspaces of protected windows even after a thirty year period; however, this may be very different in other situations, and periodic dusting of the interspace may become necessary.⁴⁹ A visual inspection of the interspace can be carried out from the outside. The design of the EPG must provide for easy access, either from the outside or from the inside, and the fixings must be robust enough to withstand periodic removal and re-installation. In many cases, this operation may be possible from a mobile elevated working platform, but it may require scaffolding. The temporary removal of glazing and the cleaning of historic stained glass should only be undertaken by qualified conservators. They can also advise on whether the EPG system is performing adequately.

11 ENVIRONMENTAL SURVEY AND MONITORING

There are two main ways in which the effects of protective glazing systems are monitored: using glass sensor dosimeters and environmental monitoring. While there is an overlap between the two approaches, the information provided by the two systems is different. Environmental monitoring examines the microclimatic parameters which cause the glass to deteriorate and the way in which they can be modified by control measures such as protective glazing. The dosimeter systems examine the impact on the glass itself of the environmental, and other, deteriorogens and by comparing protected and unprotected glass allows the effect of the protective glazing to be evaluated.

11.1 Glass Sensor (Dosimeter) Monitoring

The glass sensor method uses sections of sensitive glass exposed in different locations to act as dosimeters for the environmental conditions.⁵⁰ By selecting the glass composition and surface treatment of the glass sensors, they react within months to processes that would normally cause damage over many years or centuries.⁵¹ To cover the full range of environmental conditions, 12 months' exposure of the glass sensors is generally used.⁵² The surface corrosion can then be measured using infrared spectroscopy to determine the thickness of the weathering layer. These glass sensors have been used in a number of different European protective glazing monitoring projects, sometimes in conjunction with environmental monitoring.⁵³ Where microbiological growth is a factor in the deterioration process, these sensors are ineffective as the microorganisms do not colonise the test glass in a predictable manner.



Figure 38. Glass sensors in place on the internal and external faces of the glazing at Holy Trinity Church, Long Melford.

11.2 Environmental Monitoring

Environmental monitoring involves measuring and recording of specific environmental parameters in different locations on the glass and in the building in order to understand the behaviour over time of the individual and combined parameters on the glass, influenced by conditions elsewhere, in its unprotected state or with EPG in place. The presented case studies, conducted by the author over the last 15 years, have used environmental monitoring, which is described in detail below.

11.2.1 Aims and Methodology

As discussed above, stained glass windows form an integral part of the building envelope and act as an interface between internal and external microclimate and the environmental conditions which affect them result from the performance of the building as a whole. Therefore, a well-designed study will monitor the conditions in the building as a whole, including artificial influences such as heating and building use, alongside the condition on the glazing itself.

When monitoring EPG systems, it is common also to monitor conditions on an unprotected window containing similar historic glass, preferably close by on the same wall (the control window). In some cases two control windows, one facing north and the other facing south will be monitored in order both to understand environmental conditions on different elevations but also to anticipate the probable performance of EPG on different elevations of the building.

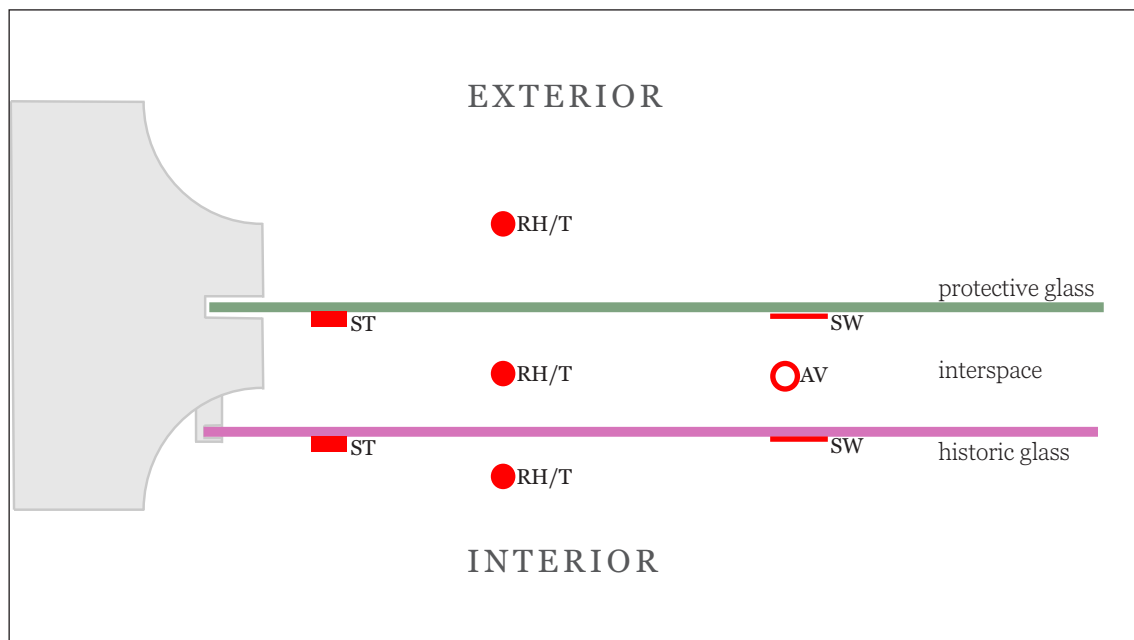

Figure 39. Sensors are often set up as illustrated, when looking down on the protective glazing in cross section.

11.2.2 Environmental Monitoring Equipment and Parameters

In most cases discussed in this report the parameters being measured are relative humidity (RH), ambient temperature (AT), surface temperature (ST), air velocity (AV) and surface wetness (SW). In addition, a number of parameters are calculated, including dew point temperature (DPT), absolute humidity (AH) and condensation.⁵⁴ Monitoring equipment is normally installed at the same time as the trial protective glazing, as sections of glass will need to be identified, removed and replaced by the stained glass conservator, in order to allow sensors to be attached to the glass surface. Where possible the sensors are positioned centrally in the window, giving an average effect across the protective glazing system, rather than measuring close to the vents.⁵⁵

Monitoring has been carried out using an Eltek RX250 telemetric data logger. RH and AT were measured using Sensirion SHT77 sensors and ST with EU-U thermistors. AV was measured using E+E Elektronik EE66 sensors.⁵⁶ SW was originally assessed using twin copper strips, but more recently has been measured using Campbell Scientific 237f flexible sensing grids with 100k Ω resistor. In both cases these measure electrical resistance, which gives an indication of whether the surface is wet or dry.

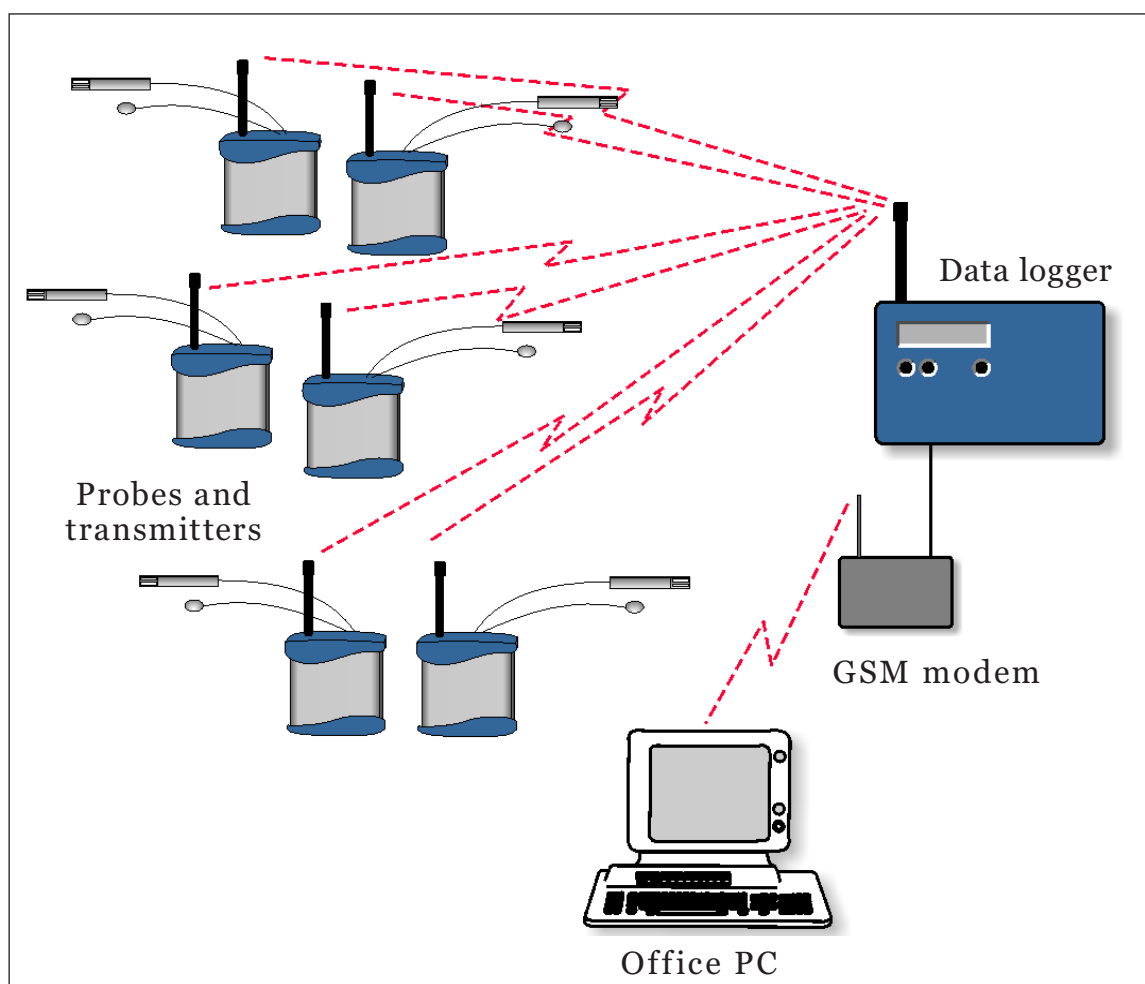

Figure 40. Schematic diagram showing the layout of the monitoring system.

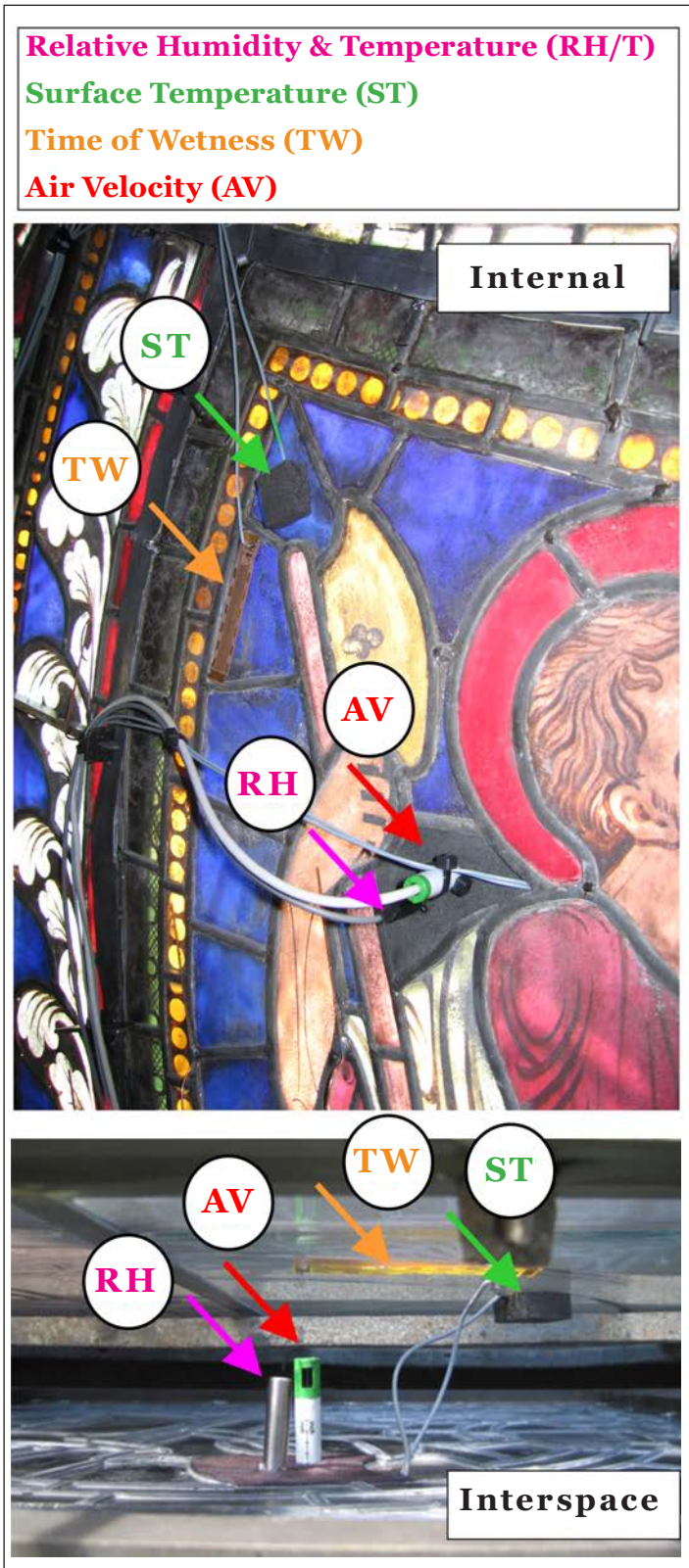

Figure 40. Details of mounted sensors.

Internal RH/AT probes are suspended in front of the glass from available fixing points on the ferramenta. The interspace RH/AT and AV probes are mounted horizontally with the sensor in the centre of the interspace between the two layers of glass. To support the probes in position, a section of non-original glass is replaced with a temporary plastazote template, with holes cut to the diameter of the probe shafts. SW probes were attached to the glass surface using Paraloid B72™. The adhesive was applied to a small block of plastazote™, holding it in place whilst also thermally insulating the back of the ST sensor.⁵⁷ On modern glass, an epoxy resin was found to be necessary to attached ST sensors due to the high-temperature fluctuations.

Data was logged on all channels at 10-minute intervals. Downloading was undertaken remotely via GSM modem and processing and charting of the data was carried out with Eltek Darca Heritage and Microsoft Excel software.

12 CASE STUDIES

A significant number of European case studies have been published in the literature as discussed above, yet few have come from the UK. However, in recent years work has been undertaken in the UK to monitor the performance of a considerable number of EPG installations (full installations and trials) of which a number of significant examples are included as case studies (below). The case studies have also been used as a basis for CFD modelling simulations (discussed below), examining the impact that changes in the design of protective glazing have on its functionality and effectiveness.

The results of the UK studies have shown that, as reported in the literature, in well maintained heated buildings, condensation on historic glazing could be almost entirely prevented by the use of well designed EPG. This can be seen in the examples below at Canterbury Cathedral, Lincoln Cathedral, Long Melford and The Vyne. So robust was the system that, when background conditions were benign, even sub-optimal designs, with shallow interspaces and small uneven vents, provided a considerable level of protection.

Similar to the literature findings, on internally ventilated systems the frequency and intensity of temperature fluctuations on the historic glass decrease compared with the unprotected control window. However, within the interspace the fluctuations are both large and numerous with condensation occurring on the, often colder, modern protective glass.

Air flow speeds in the interspace were seen to relate to the size of the temperature difference between the internal and interspace measurements, with greater temperature differences, and thus greater buoyancy variations, increasing the air velocity as seen at the Vyne.

Whilst most studies have focussed on tall, thin lancet windows, protective glazing was also shown to be effective on complex rose windows with multiple lights, such as the Dean's Eye at Lincoln Cathedral where condensation was almost entirely controlled despite the complex geometry of the protective glazing panels.

In unheated, or infrequently heated buildings and those where a low level of maintenance can cause an unusually high background RH in the church, EPG can still reduce the number of condensation events on the historic glass, although, as seen at St Mary and St Barlok's, Norbury, periodic condensation can still occur. In such cases, where microbiological attack has occurred on the historic glass, removal of condensation is critical in controlling further growth. This clearly demonstrates that controlling deterioration is not simply a function of the protective glazing but also of the overall management of the building environment.

Significant airflow was also shown to occur on historic glazing without EPG. Kings College, Cambridge has no protective glazing, but very tall windows and a high level of under floor heating. Monitoring has recorded greater condensation higher up on the north window. In comparison conditions on the south window are similar at high and low levels. The effects of temperature on air speeds were again clear in this example, with air flow recorded due to the temperature differences despite the lack of protective glazing. These variations appeared to occur due to the dominant heating influence, the mechanical heating on the north which has a greater impact on the lower glass and solar gain on the south which has a broadly even effect.

12.1 The Vyne Chapel

16th-century private chapel attached to stately home in Basingstoke, Hampshire (owned by the National Trust).

The stained glass has serious corrosion pits on the outside and a loss of glass paint on internal surfaces, in part due to poor firing of the glass paint and enamel when created. This has left the enamel soft and vulnerable to abrasion.

A protective glazing trial was undertaken to determine whether damaging cycles of condensation and surface wetness were occurring on the body of the glass and the painted details.

| | |
|-----------------------|-------------------------------------------------------------------------------------------------------------------------------------------|
| Date of stained glass | 16th century (c.1525) |
| Window position | Central upper panel, East window |
| EPG design | Leaded 3mm horticultural glass, fitted in original glazing grooves, internally ventilated |
| Orientation | East |
| Height | 1.95 m |
| Width | 0.47m |
| Ventilation gaps | 10 mm base (approx.) 25 mm top (approx.) Full width of panel |
| Interspace depth | 45-50 mm (approx.) |
| Building condition | Well maintained |
| Heating | Heating: stand-alone electric radiators, controlled on conservation-heating protocol (humidistat with upper and lower temperature limits) |

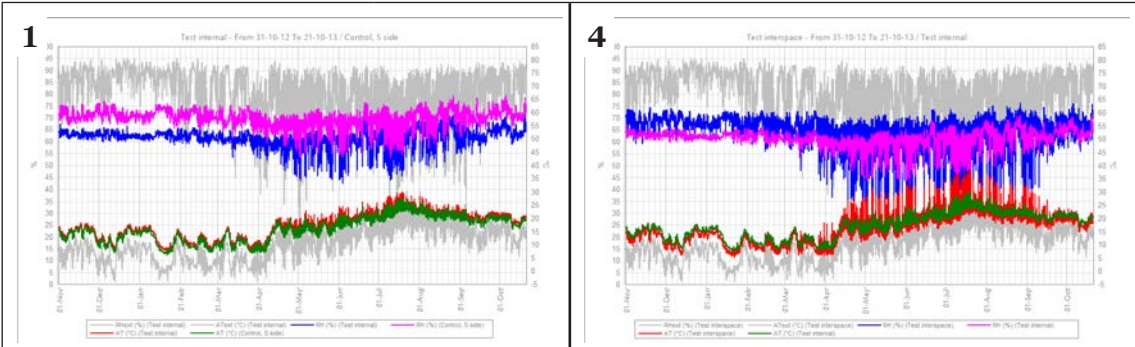

1. Environmental monitoring determined the protected stained glass (red & blue) was drier and warmer than the control window (an adjacent window with no protective glazing).

4. Conditions in the interspace (red & blue) were more unstable than on the internal glass (green & pink).

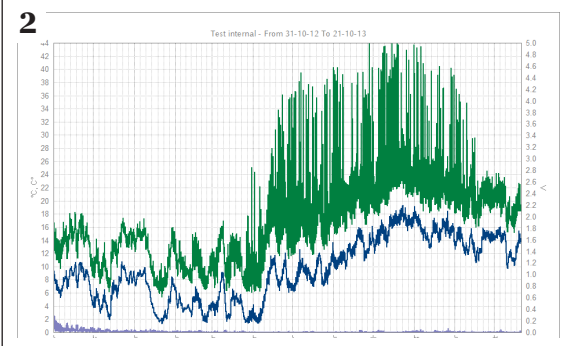

2. The results demonstrated that the surface temperature (green) of the protected historic glass remained around 5°C above the dew point (blue). This means condensation is unlikely to have occurred.

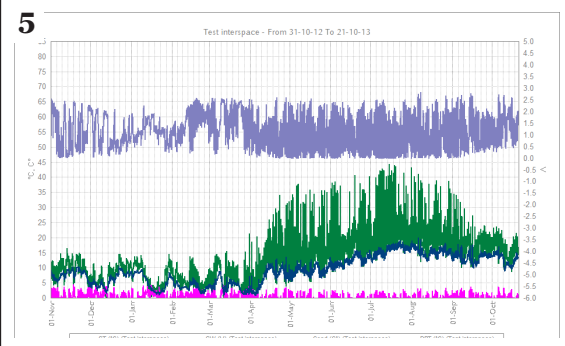

5. Similar to the unprotected control window, the modern protective glass had significant surface wetness (grey), as the dew point (blue) and surface temperature (green) regularly cross.

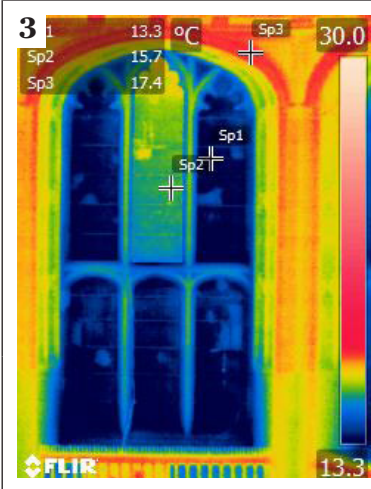

3. The increased temperature of the internal glass was captured using thermal imaging. The lancets were unprotected.

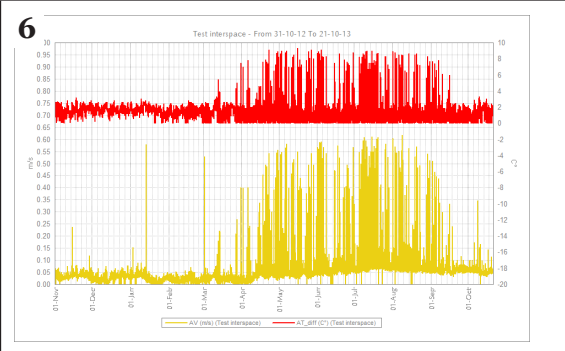

6. The air velocity (yellow) was found to follow changes in the size of the difference between the interspace and internal temperatures (red).

Conclusions: Data collected from the protected historic glass indicated condensation had been entirely prevented by the internally ventilated protective system.

12.2 Canterbury Cathedral, Kent

12th-century Trinity Chapel.

Window sII, conserved in 1979: including releading with thick comes and externally ventilated EPG. Since this intervention there has been significant distortion of the stained glass panel.

Window Clerestory SV: conserved in 2011 and given internally ventilated EPG.

These windows have almost the same orientation, but are at different heights and are ventilated differently.

| | |
|-----------------------|------------------------------------------------------------------------------|
| Date of stained glass | Early 13th century (1207–13) |
| Window position | Trinity Chapel, sII |
| EPG design | Externally ventilated (1979) |
| Orientation | South east |
| Height | 7 m |
| Width | 1.97 m |
| Ventilation gaps | 100 x 10 mm base (approx) 250 x 10 mm top (approx) 2 each top & bottom |
| Interspace depth | <5 to 60 mm (approx) - distortion |

| | |
|-----------------------|--------------------------------------------------------------------------------------------|
| Date of stained glass | Late 19th century |
| Window position | Trinity Chapel Clerestory, SV |
| EPG design | Internally ventilated (2011) |
| Orientation | South east |
| Height | 3.65 m |
| Width | 1.06 m |
| Ventilation gaps | 75 x 20 mm base (approx) 75 x 20 mm top (approx) 2 each top & bottom in wooden frame |
| Interspace depth | 55 mm (approx) |

| | |
|--------------------|---------------------------------------------------|
| Building condition | Well maintained |
| Heating | Hot-water radiator system with thermostat control |

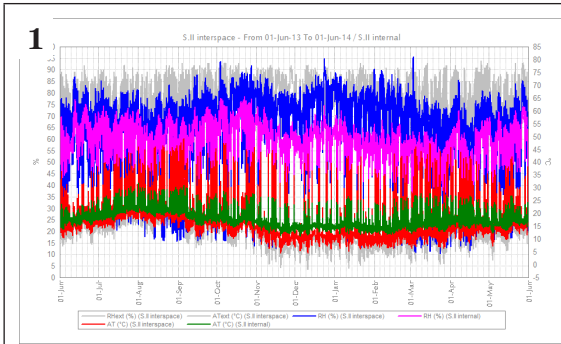

1. The lower sII window has clear patterns of solar gain leading to rapid drops in RH. These are smaller on the historic glass (green & pink) than on the modern glass.

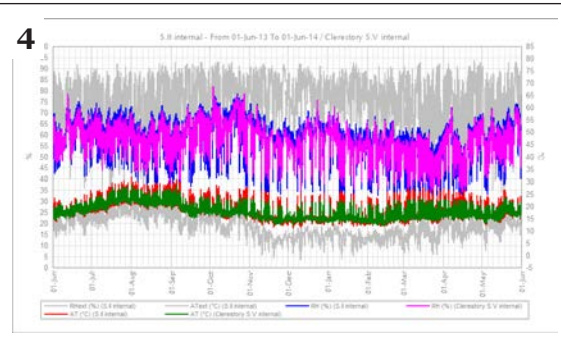

4. The amplitude of internal fluctuations is greater on sII (red & blue), possibly due to direct late morning sunlight, compared with the SV window (green & pink).

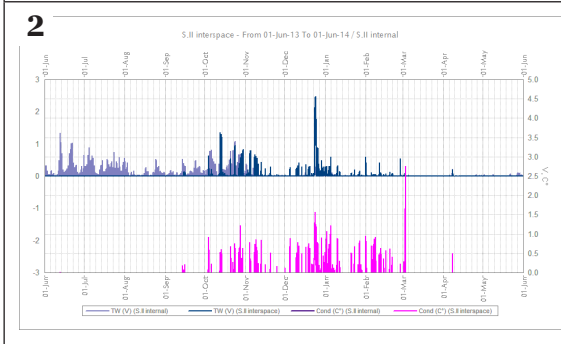

2. In the interspace surface wetness (top, blue) and condensation (bottom, pink) occurs during the winter months. Minor surface wetness was recorded on the sII historic glass (grey) in the summer months. This may result from the external ventilation of the sII protective glazing, the restricted vent size, or restricted interspace.

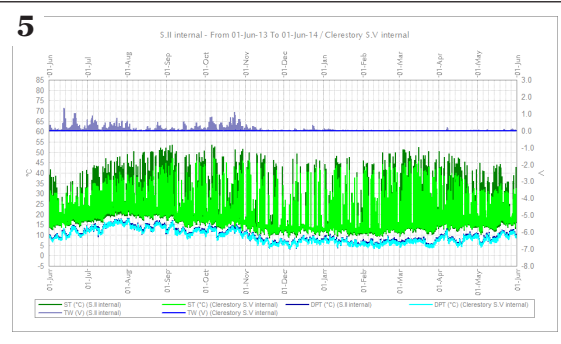

5. Internal surface temperatures are also greater on sII (green) and although the dew point (navy) was not crossed, surface wetness (grey) was recorded in the summer months.

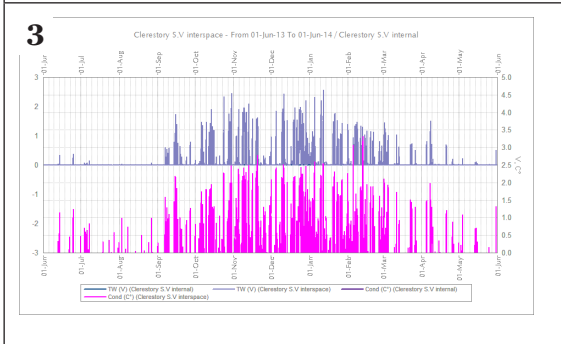

3. For the clerestory SV window there are again smaller internal variations compared with the interspace. The SV interspace has notable periods of surface wetness (grey) and condensation (pink), whereas the internal stained glass has almost none (blue & purple).

Conclusions: For SV, with an internally ventilated system, minimal condensation or surface wetness is recorded on the historic glass, although there are regular events on the external protective glass in the winter. On sII with an externally ventilated system there is some surface wetness on the historic glass in summer although far less than on an unprotected control. On the historic glass there is less condensation than for SV modern glass.

12.3 Long Melford Holy Trinity, Suffolk

15th-century church.

Stained glass has severe corrosion, with external pitting leading to considerable loss of the glass body. Internally there has been deterioration of the glass paint and enamels as a result of condensation and microbiological growth. Although this deterioration is slow, it is ongoing.

Trial undertaken to determine whether EPG would reduce instances of condensation.

| | |
|------------------------------|---------------------------------------------------------------------------------------------------------|
| Date of stained glass | 15th century |
| Window position | North aisle nXXII |
| Protective glazing | Variety of glazing types tested, fitted in original glazing grooves, internally ventilated (isothermal) |
| Orientation | North |
| Height | 4.8 m |
| Width | 1.75 m |
| Ventilation gaps | 30 x 10 mm base (approx) 30 x 10 mm top (approx) 2 each top & bottom in lead skirt |
| Interspace depth | 50-60 mm (approx) |
| Building condition | Well maintained |
| Heating | Periodic heating with low-temperature radiant pew radiators |

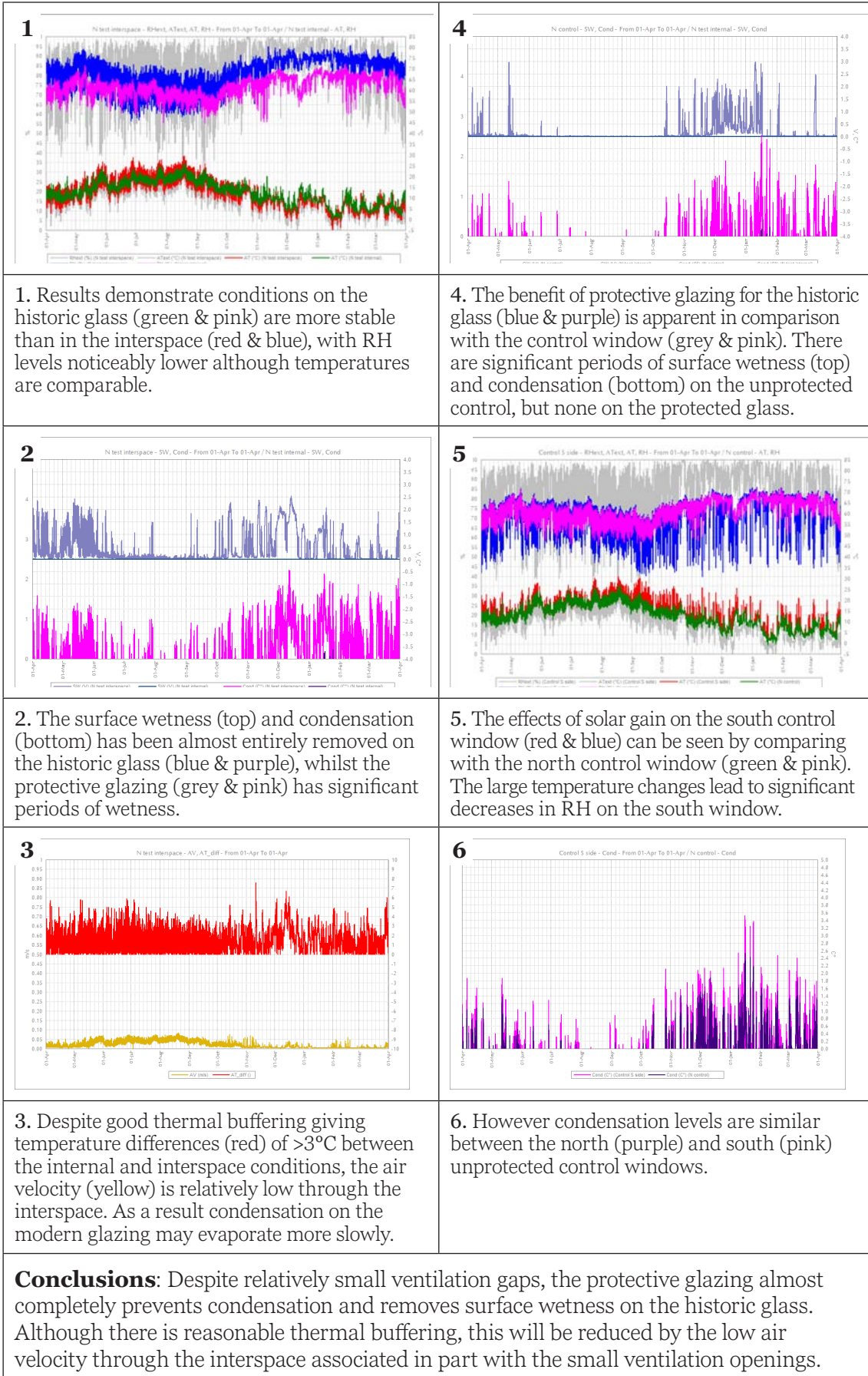

1. Results demonstrate conditions on the historic glass (green & pink) are more stable than in the interspace (red & blue), with RH levels noticeably lower although temperatures are comparable.

4. The benefit of protective glazing for the historic glass (blue & purple) is apparent in comparison with the control window (grey & pink). There are significant periods of surface wetness (top) and condensation (bottom) on the unprotected control, but none on the protected glass.

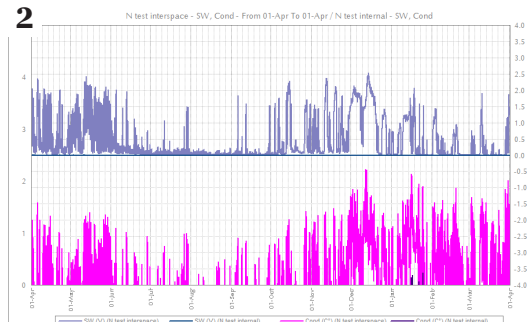

2. The surface wetness (top) and condensation (bottom) has been almost entirely removed on the historic glass (blue & purple), whilst the protective glazing (grey & pink) has significant periods of wetness.

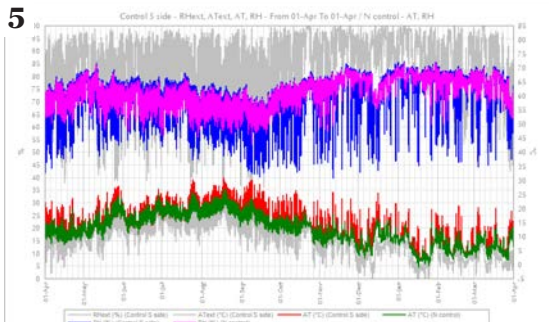

5. The effects of solar gain on the south control window (red & blue) can be seen by comparing with the north control window (green & pink). The large temperature changes lead to significant decreases in RH on the south window.

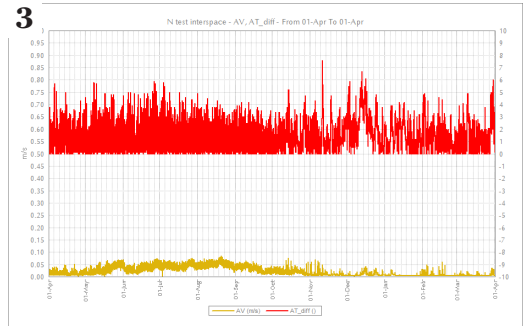

3. Despite good thermal buffering giving temperature differences (red) of >3°C between the internal and interspace conditions, the air velocity (yellow) is relatively low through the interspace. As a result condensation on the modern glazing may evaporate more slowly.

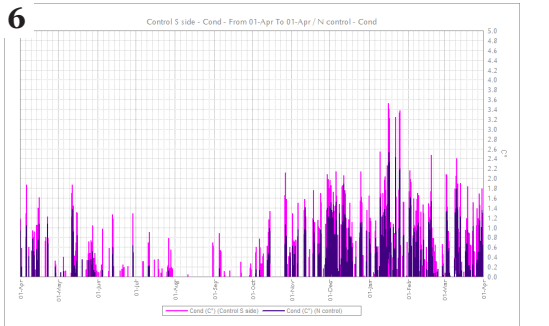

6. However condensation levels are similar between the north (purple) and south (pink) unprotected control windows.

Conclusions: Despite relatively small ventilation gaps, the protective glazing almost completely prevents condensation and removes surface wetness on the historic glass. Although there is reasonable thermal buffering, this will be reduced by the low air velocity through the interspace associated in part with the small ventilation openings.

12.4 Lincoln Cathedral

Dean's Eye: 13th-century rose window in north transept.

Glass deterioration and corrosion on the external and internal surfaces. The internal fired oxide paints decorating the surface were also reported to be affected.

As part of a comprehensive conservation programme, small individual sections of internally ventilated EPG were added to limit further deterioration.

| | |
|-----------------------|--------------------------------------------------------------------------------------------------------------|
| Date of stained glass | 13th century |
| Window position | Rose window (known as Dean's Eye) |
| Protective glazing | Plain glass, lead lines following original, fitted in original glazing grooves, internally ventilated |
| Orientation | North |
| Height | 8 m total height of rose |
| Width | 1 m diameter (small roundels) |
| Ventilation gaps | Each panel is surrounded by a lead skirt, to prevent light halos, which can be moved to adjust the vent size |
| Interspace depth | 55 mm (approx) |
| Building condition | Well maintained |
| Heating | Hot-water radiator system with thermostat control |

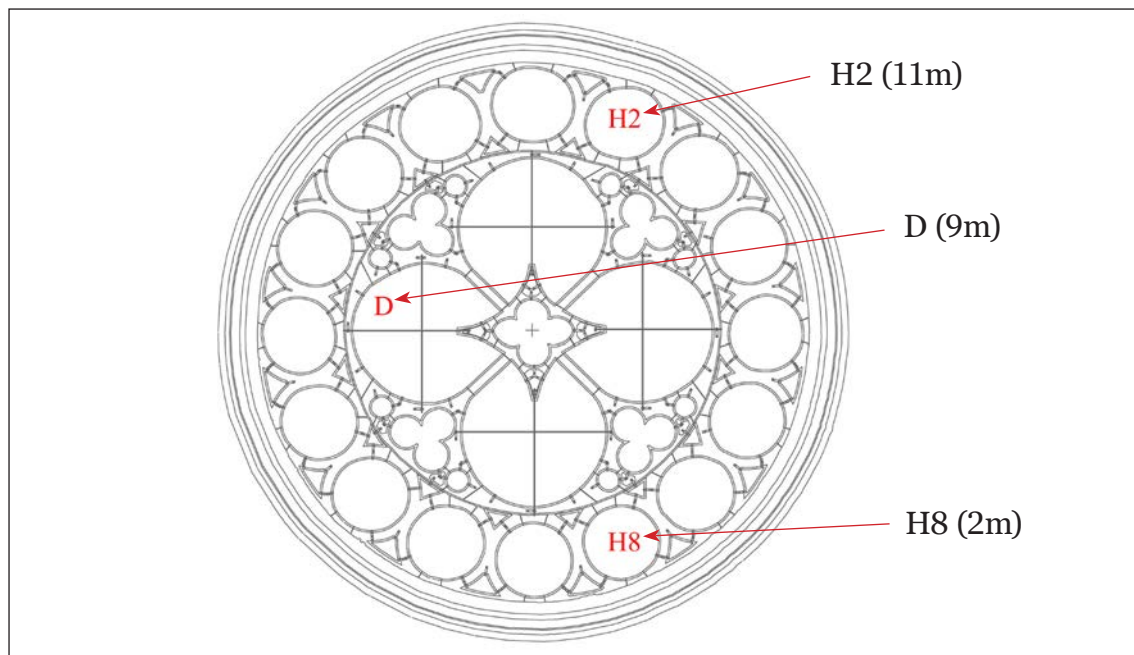

The window has 77 panels. Measurements were taken at three separate locations. Although the primary ventilation was at the top and bottom of each section of EPG, air leakage also occurred around the edges.

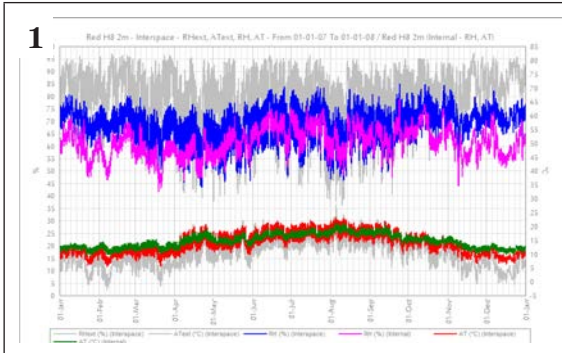

1. Although shown for position H8, data was similar for all three locations demonstrating the internal stained glass (green & pink) was subjected to smaller fluctuations in temperature and RH than the interspace (red & blue).

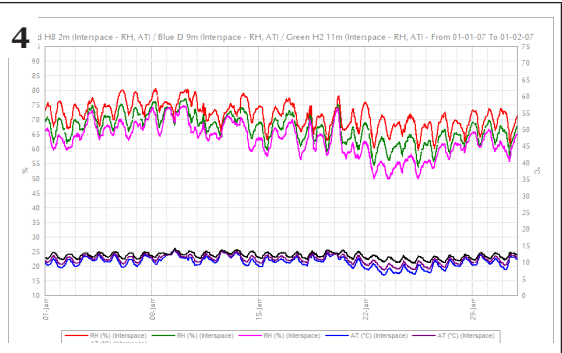

4. There is a clear separation in the interspace temperatures at different heights, most apparent in the winter (below), but seen across the year. H8 is lower, cooler and damper, then D, followed by H2, which is highest, warmest and driest.

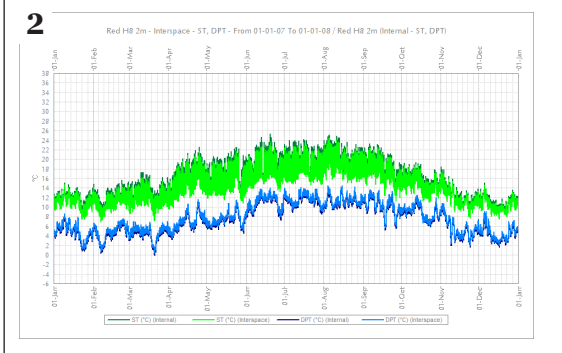

2. There is also a marginal but consistently higher ST on the internal glass (dark green) and lower DPT (dark blue) indicating condensation is unlikely to have occurred on the historic glass. Minimal surface wetness was recorded on the protective glazing and almost none on the historic glass.

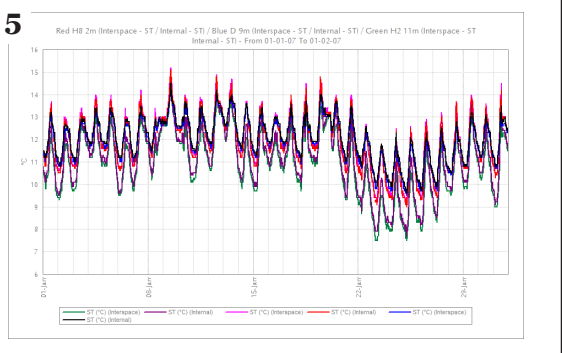

5. The same trend is observed for surface temperatures, with H8 coolest and H2 warmest, and D generally between the two values. At each height the internal and interspace surface temperature data forms an approximate pair, with very similar temperatures. Moving up the window the temperatures increase, but the paired pattern is retained.

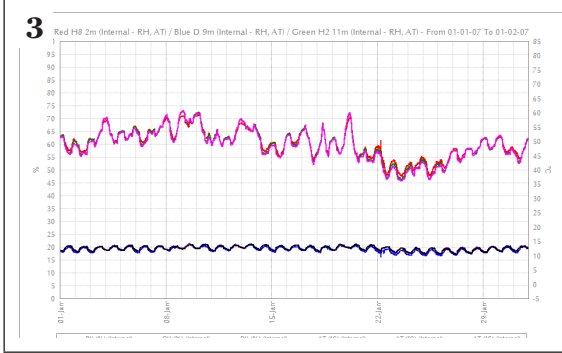

3. Internal conditions are relatively similar for all three measuring points, with very little difference recorded.

Conclusions: Despite the very different geometry of the rose window to other examples and the individual small section design of the protective glazing, the system prevented condensation on the internal stained glass, with almost no surface wetness recorded in any of the three locations.

12.5 Norbury St Mary and St Barlok's , Derbyshire

Stained glass in 14th-century chancel.

Glass is in poor condition, with severe corrosion leaving holes in some areas. Extensive conservation programme in 2000s, with cleaning to remove algal growth; but building moisture problems not resolved.

Stained glass was rapidly recolonized by green algal growth on the interior, which retains moisture (facilitating glass corrosion). EPG trial installed on two windows, and afterwards throughout the chancel.

| | |
|-----------------------|------------------------------------------------------------------------------------------------------------|
| Date of stained glass | 14th century (c.1306) |
| Window position | Tests all S.IV and central light N.IV |
| Protective glazing | Internally ventilated, north side plain horticultural glass, south side as north but leaded, bronze frames |
| Orientation | North and South |
| Height | 3.15 m (individual light), 5 m (total) |
| Width | 0.8 m (individual lighth), 2.75 m (total) |
| Ventilation gaps | Sections moved forward to the inside by approx 20 mm |
| Interspace depth | 50 mm (approx) |
| Building condition | Poor |
| Heating | Hot-water radiator system with thermostat control |



The trial demonstrated that protective glazing could limit algal growth, despite the damp building. Seen on the left is the N.IV stained glass light that was protected during the trial, and on the right is the unprotected control.

- Convective radiators

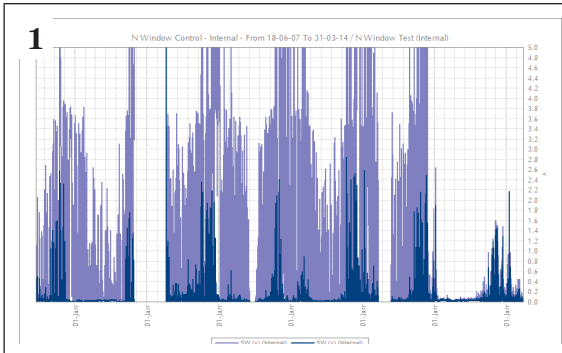

1. Comparison of the test north window (blue) with the control (grey) demonstrates how much the protective glazing reduced the condensation. Protective glazing was added to the control light last year, leading to a dramatic decrease in condensation levels.

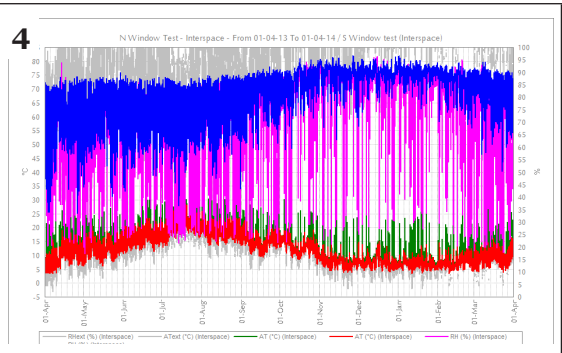

4. In addition the south windows are subjected to significant solar gain, leading to larger temperature variations, which in turn cause large RH fluctuations. This effect is particularly noticeable in the interspace (green & pink).

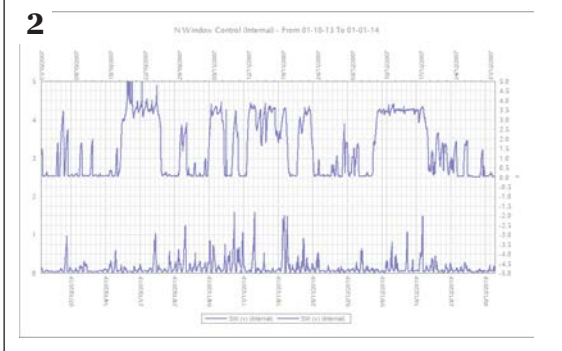

2. Without protective glazing (top) there were significant periods, when the internal surface remained wet. After protective glazing (bottom) was installed the control window now dries more rapidly.

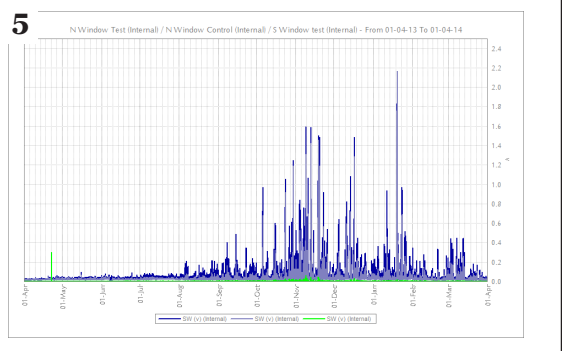

5. Analysis of the surface wetness shows there has been some condensation on the internal surfaces of the north-facing historic glass (grey & blue), but almost none on the south glass (green). However as previously illustrated this is significantly less condensation than would occur without the protective glazing.

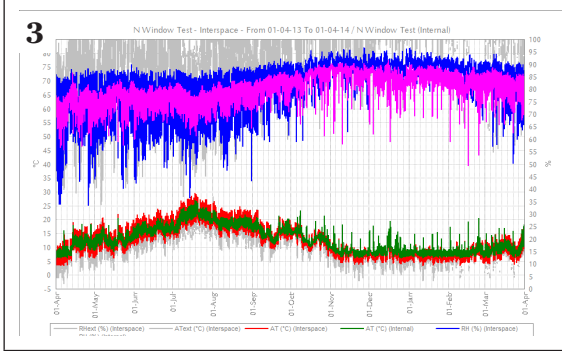

3. Conditions in the interspace (red & blue) vary much more than on the historic glass (green & pink).

Conclusions: The protective glazing reduces the extent of surface wetness from condensation even in a damp and infrequently heated building, removing weathering effects and limiting condensation will help limit any further glass corrosion, as well as reducing the speed at which algal growth recolonizes the stained glass windows. However, in a church with a typical microclimate the same glazing design would be expected to prevent all condensation. This demonstrates the importance of managing the building environment as well as the protective glazing design.

12.6 Princeton St Mary, Devon

19th-century church.

The historic glass of this 19th-century church has suffered structural deformation caused by wind loading. Whilst the body of the stained glass is in good condition, there is extensive loss of glass paint, due to vulnerable original technique. High levels of microbiological growth have occurred on the internal surface of the glass.

There is significant liquid water penetration and high moisture levels in the walls.

| | |
|-----------------------|--------------------------------------------------------------------------------------------------------------------------------------|
| Date of stained glass | 20th century (c.1910) |
| Window position | South lights I & II, East window |
| Protective glazing | 6-mm thick Perspex, SI externally ventilated (test 1), SII internally ventilated (test 2) |
| Orientation | East |
| Height | 2.77 m |
| Width | 0.6 m (individual light) |
| Ventilation gaps | Base: (<i>int. vent</i> 200 mm, <i>ext. vent</i> 20 mm (approx) both full width of panel Top: 120 x 120 mm (approx) central lobe |
| Interspace depth | 30 mm (approx) |
| Building condition | Poor |
| Heating | Unheated |

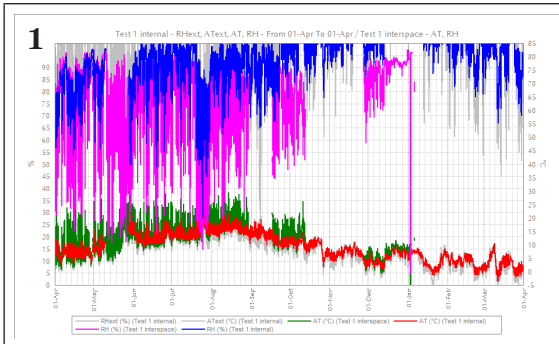

1. The historic glass had smaller temperature changes than the interspace protective glazing. However for the externally ventilated test 1 the interspace is drier than the internal glass, which is the opposite of the expected conditions.

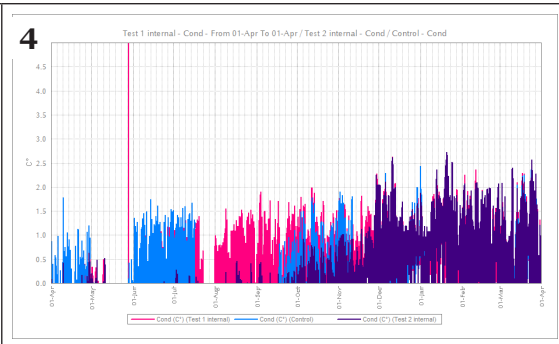

4. There is little available data for the control window (blue), although the data suggests conditions are similar to the externally ventilated test 1 (pink). Slightly less condensation is occurs for the internally ventilated test 2 (purple).

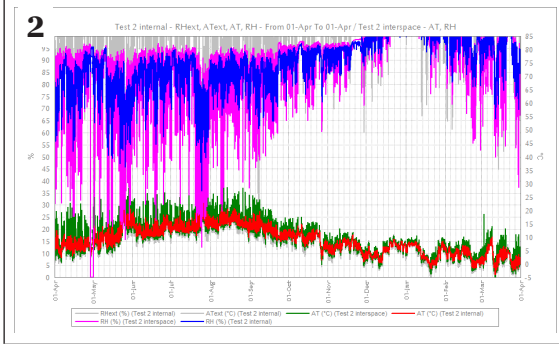

2. This may result from a drift in calibration for the RH sensor due to the high moisture levels, as the expected smaller fluctuations but similar RH levels were seen in test 2.

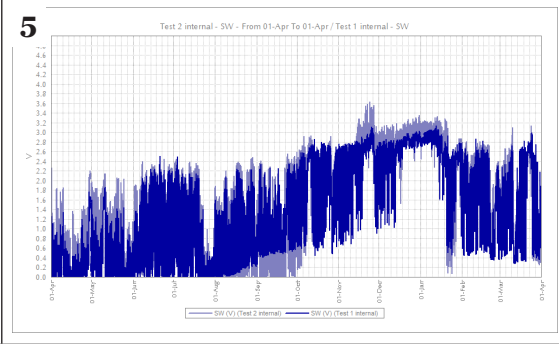

5. However the surface wetness data is similar for both test 1 (blue) and test 2 (grey) indicating that the internal face of the stained glass has been wet for significant periods.

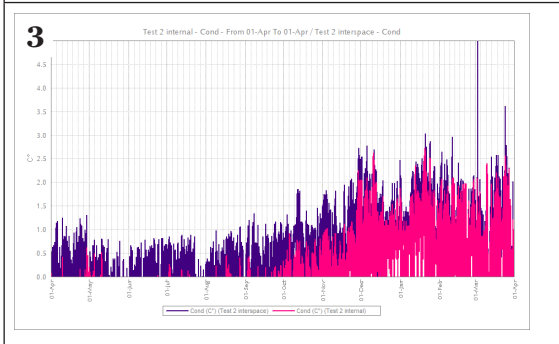

3. For test 2, the internal face (pink) has fewer condensation events than the interspace (purple), but still far greater than would typically be expected for internally ventilated protective glazing.

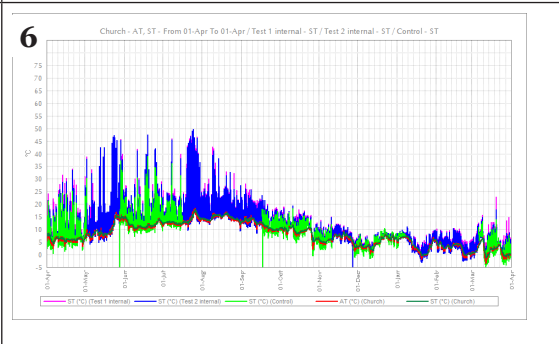

6. The surface temperature data indicates that the control window (light green) is slightly colder, but not significantly when compared with the two test windows (pink & blue), all fluctuating more, but at a similar average value to the church internal ambient conditions (red & green).

Conclusions: Whilst the Perspex protective glazing test demonstrated that the magnitude of fluctuations in temperature and RH on the internal stained glass could be reduced, temperatures remain similar to the unprotected control window. As a result, condensation remains high, in part due to the cold internal temperatures and elevated RH in the unheated, damp church. If the thermal buffering of the stained glass does not increase as a result of the protective glazing, then the protection of the internal surface is limited. However, full protective glazing could still be successful in limiting damage due to driving rain and wind loading.

12.7 King's College Chapel, Cambridge

15th-century chapel famous for its stained glass.

Whilst the structural condition of the glazing is reported to be good, the painted detail is in poor condition in places.

Environmental monitoring carried out to determine whether the current environment is aggressive to the painted details (in particular, whether condensation is occurring on the historic glass).

| | |
|-----------------------|----------------------------------------|
| Date of stained glass | 16th century (1515–1547) |
| Window position | NX (9m & 13m) SX (9.5m & 13m) |
| Protective glazing | None |
| Orientation | North and South |
| Height | 5.3m (individual light), 13.4m (total) |
| Width | 0.72m (individual light), 4.7m (total) |
| Ventilation gaps | N/A |
| Interspace depth | N/A |
| Building condition | Well maintained |
| Heating | Underfloor |

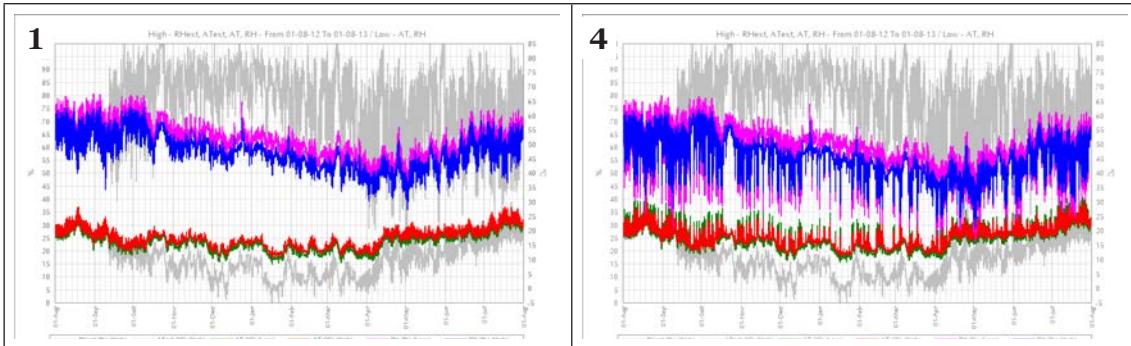

1. Whilst protective glazing has not been installed at King's College, the environmental monitoring demonstrates the difference in conditions at different heights in the window. On the north side at the higher measuring point AT is greater and RH is lower (blue) compared to lower down on the same window (pink).

4. On the south window large fluctuations are seen at both high (red & blue) and low (green & pink) levels, with little difference between the two sets of data..

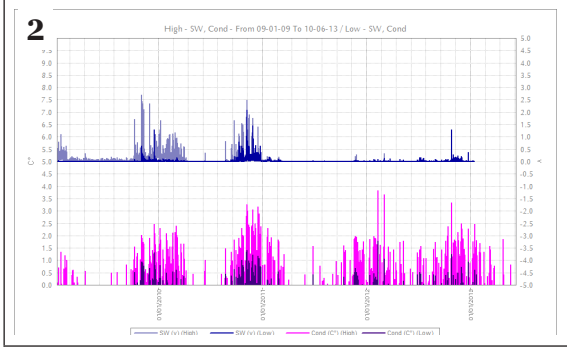

2. Whilst the DPTs are similar, the greater ST fluctuations are at high level, mean this often drops below the DPT over night, leading to greater condensation (pink) and surface wetness (grey).

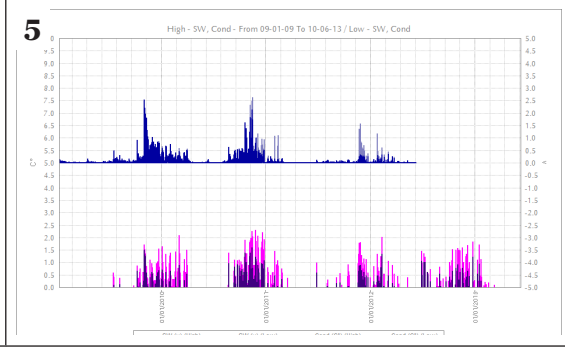

5. As a result there is little difference in the amount of surface wetness (top, grey & blue) and condensation (pink & purple) recorded high and low, respectively, on the window.

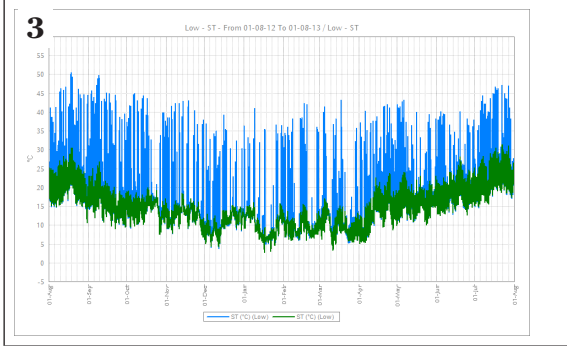

3. At both high and low levels ST on the north (green) fluctuates significantly less than on the south (blue) window, due to the effects of solar gain.

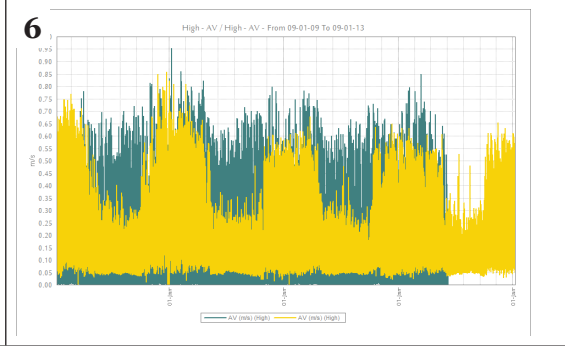

6. The greater temperature changes on the south window lead to more constant, high air speeds (green) compared to the north window (yellow). On the north window air velocity is comparable to the south window in the summer, but significantly lower in the winter months. The air speeds suggest condensation will rapidly evaporate.

Conclusions: Condensation occurs during the winter periods at high and low levels, on both the north and south unprotected stained-glass windows. Environmental monitoring shows there are significant temperature changes throughout the year on the south windows, due to solar gain, which leads to high air flow across the window. In comparison, the surface temperature of the north window shows less variation, even in the summer months. However, the greater temperature difference in the summer leads to increased air flow.

13 CFD MODELLING: PERFORMANCE AND ENERGY EFFICIENCY

While the basic protection mechanism of EPG is well understood, there is a considerable lack of knowledge about how specific design details influence the way in which systems function. This is a particular problem when protective glazing is required on a historically and aesthetically sensitive building, where there are considerable design restrictions. In addition, there has been limited work undertaken to assess the possible impact on energy efficiency provided by EPG systems.

To address both areas, a series of computational fluid dynamic (CFD) models were constructed so that the performance of a number of different designs of ventilated secondary glazing could be evaluated.

The specific aim of the energy efficiency modelling was to examine the improvement in thermal buffering that could be provided by secondary glazing in the context of an historic building and therefore the energy savings which might be possible. For the protective glazing modelling, the key questions were the impact on functionality of the design details, in particular vent and interspace geometries.

13.1 Tests

13.1.1 Functional Computer Model

The modelling was undertaken in two phases with different models constructed for each to better address specific question under consideration. In both phases, the system considered in the model involves placing modern glass on the external side of the installation, with the interspace between the two layers of glazing ventilated, at the top and bottom of the window, to the interior (or exterior) of the building. In this system, airflow occurs through the interspace as a result of the relative buoyancy of the air within the interspace in comparison to the air within the body of the building. The relative buoyancy is determined largely by the difference in temperature between the air in the interspace and that in the body of the building. The air in the interspace will be heated or cooled as a result of conductive or radiant heat transfer through the two layers of glass.

In Phase I the protective glazing model window was examined using Fire Dynamic Simulator (FDS) software,⁵⁸ which forms a space around the window and examines how the region behaves. This allows air flow in and out of the window and includes equations on radiation, conduction, convection, buoyancy and turbulent air flows that are similar to those found in protective glazing systems.⁵⁹

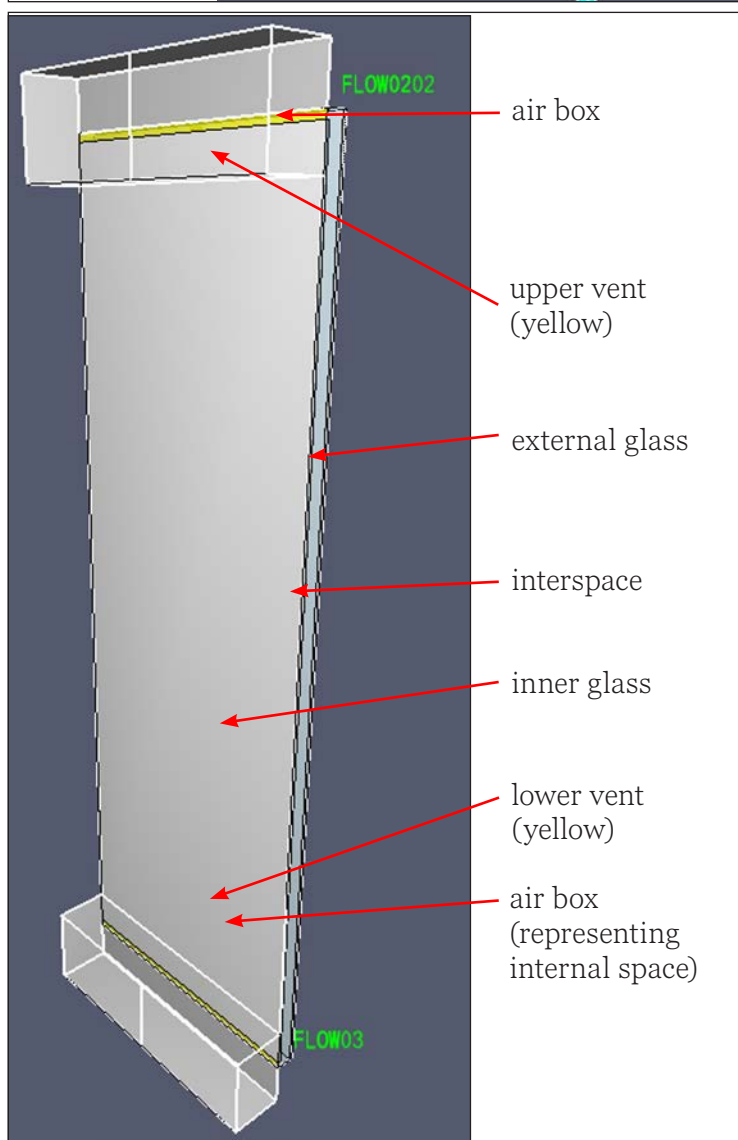
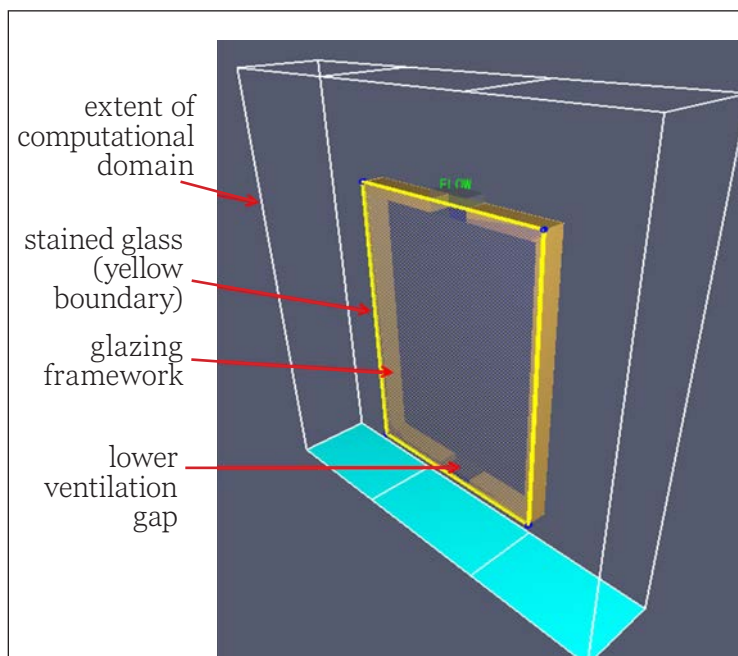

In Phase I the modelled window was 4 m tall and 2 m wide with a 200 mm interspace depth (ventilated to the inside), which whilst larger than real situations allowed the behaviour to be simulated. Two simulations were carried out: with external conditions warmer than inside (for example a south facing window during sunny conditions) and with external conditions cooler than inside (for example a north facing window in winter when the building is heated). The model then tested the variations resulting from a ventilation gap that was the full width of the window, or a gap which was small and centrally placed.

In Phase II the model was constructed to examine specific geometries and questions that had been identified from the case studies and a literature review. In this case the geometry of the modelled window was varied to determine the impact this had on the effectiveness of the protective glazing. The baseline model was 3 m tall, 1 m wide with an interspace depth of 50 mm, which was internally ventilated with full width vents of 12mm at the top and bottom. Tests were carried out with winter conditions of 0°C outside and 16°C inside.⁶⁰

Figure 42. Phase I protective glazing model.

Figure 43. Phase II protective glazing model.

| Table 13-1. Details of the Phase II modelling parameters (note: only changes relative to the baseline case are shown; if there is no value given it will be the same as in the baseline case) | | | | | | | | | | | | |
|--------------------------------------------------------------------------------------------------------------------------------------------------------------------------------------------------|------------------------------------|-------|------------|----|----|------|------|---------|--------|---------|------------|--|
| | Scenario number | Units | 1 | 2A | 2B | 3A | 3B | 4 | 5A | 5B | 5C | |
| | | | | | | | | | | | | |
| Geometry (excluding frame) | Width | M | 1 | | | | | | | | | |
| | Height | M | 3 | 7 | 1 | | | | | | | |
| | Interspace depth | M | 0.05 | | | 0.03 | 0.01 | | | | | |
| External glass | Thickness | M | 0.01 | | | | | | | | | |
| | Solar absorptivity | % | 25 | | | | | | | | | |
| | Thickness | M | 0.01 | | | | | | | | | |
| Internal glass | Solar reflectivity | % | 15 | | | | | | | | | |
| | Solar absorptivity | % | 15 | | | | | | | | | |
| | Area (as % of interspace 'area') | % | 25 | | | | | | | | | |
| Size of vents | Aspect ratio | | Full width | | | | | | | | | |
| | Vent to inside/outside | | Inside | | | | | Outside | Inside | Outside | | |
| | Thickness as % of interspace depth | % | 0 | | | | | | | | 20 (10 mm) | |
| Ferramenta | External air temperature | °C | 0 | | | | | | 18 | 18 | | |
| | Internal air temperature | °C | 16 | | | | | | 22 | 22 | | |
| Solar insolation | Wm ⁻² | | 300 | | | | | | | | | |

To examine the effects of different window shapes the model geometry was altered to test a taller window of 7 m height and square window of 1 m height, with all other parameters remaining the same as the baseline model. Variations in the interspace depth of 30 mm and 10 mm were compared with the baseline of 50 mm, as well as the addition of ferramenta of 10 mm depth into the interspace. Scenarios to compare the internally ventilated baseline model with an externally ventilated system were also run.

Finally an internally ventilated system with summer temperatures (internal temperature 22°C and external temperature 18°C, as daily average) was compared with an externally ventilated example. The model examined whether there was a significant variation in temperatures and ventilation rates depending on the design of the protective glazing under each of the scenarios. This has been used to determine whether condensation would occur and evaluate the effectiveness of the protective glazing design.

13.1.2 Energy Efficiency Model

Models were also developed to test the impact of protective glazing on thermal efficiency of church buildings. Two church building types were modelled in Microsoft Excel to determine the likely impact on energy efficiency and heat loss with and without internally ventilated protective glazing. In both cases the church building was 16 m long, 8 m wide and 10 m tall (to the apex of a pitched roof), constructed of solid limestone walls (800 mm) with lime plaster internally (20 mm thick), an oak board (25mm thick) roof covered in 3.5 mm thick lead externally, with limestone paving floor (40 mm thick) on top of a 20 mm thick lime mortar bed above the ground.

In each case there were 4 windows of equal dimension on each of the north and south walls and a single larger window on the east wall. In the first model the windows are large, similar to a late medieval church, forming in the region of 21% of the internal surface area. In the second case the windows are small, representing an early medieval church, in the region of 2% of the internal surface area made up by the windows. The model used a target internal temperature for heating to 14°C and 1427 annual degree days of heating. The model determined how much energy would be saved by adding protective glazing to each example, compared with single-glazed windows.

13.2 Results

13.2.1 Design Efficiency of Interspace and Vent Geometry

Phase I tested the geometry of the interspace and vents on airflow through the interspace and thus the thermal buffering efficiency. As the glass surface is heated air adjacent to the glass is heated above the ambient temperature, creating a thermal boundary layer. As the air moves up and it becomes more heated, the air velocity increases and the boundary layer grows thicker. Once this layer of warm air expands to fill the interspace, air velocity can no longer increase and the flow is described as choked. This will commonly occur on a typical lancet type window >1m in height, but may not on smaller installations.

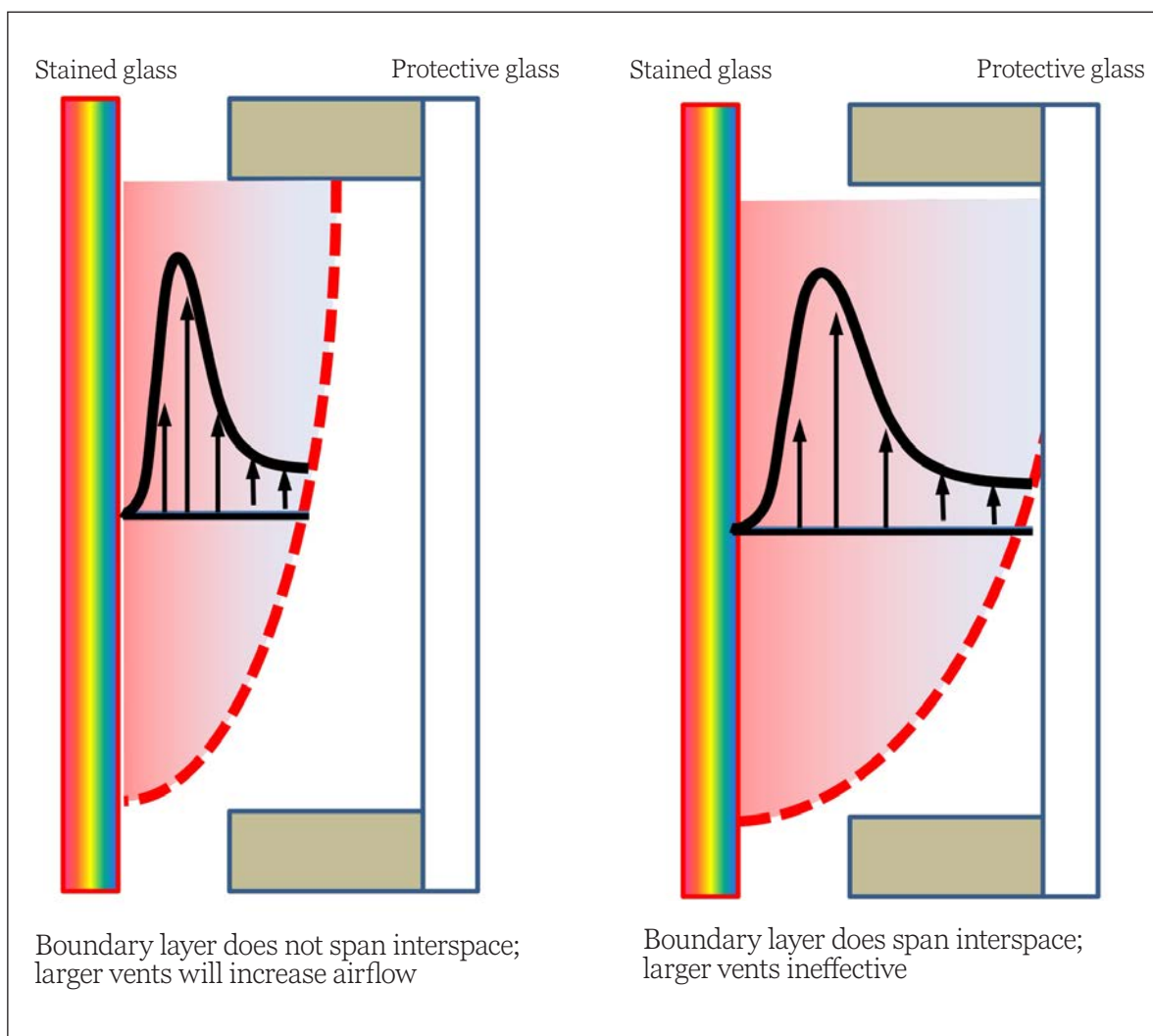
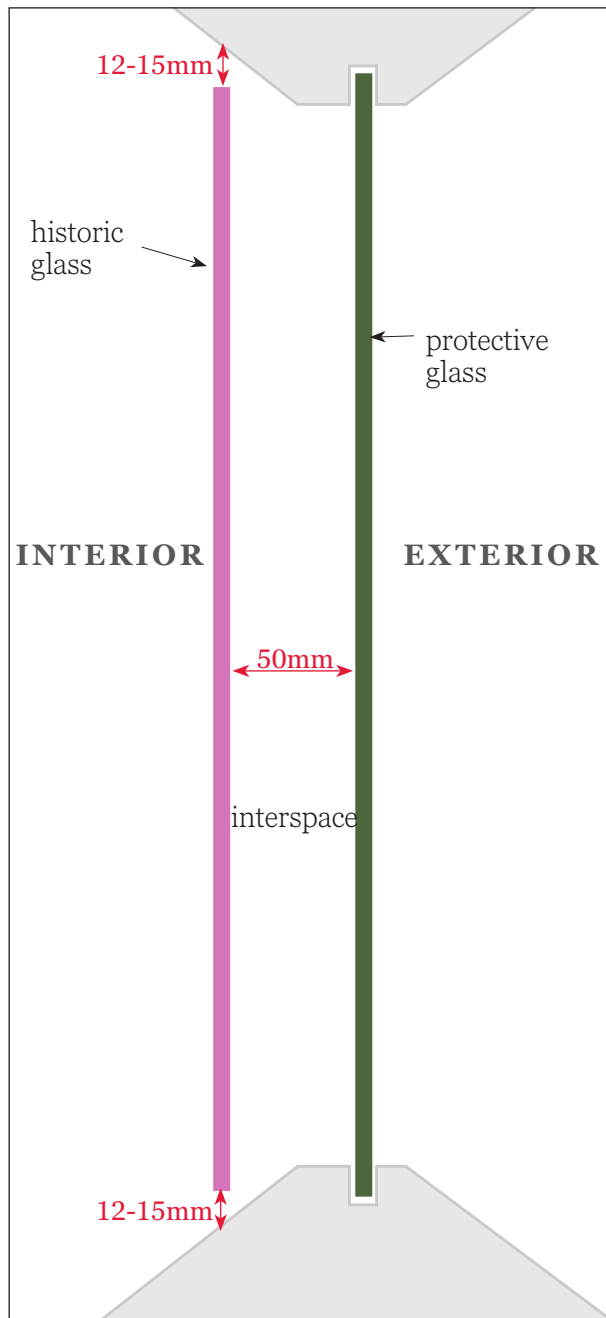

Figure 44. In the example on the left, the boundary layer has not reached the protective glass and air velocity can increase as the air moves up the glass. Once the boundary layer reaches the protective glass (right) and the air velocity has reached its maximum, this system is described as 'choked'.

As a result of the choking effect an increase in vent size of above 20% (vent area to interspace area) does not increase the air velocity. However, air flow rate can be achieved by increasing the ratio to approximately 30%. In practice, an ideal vent area would be approximately 25% to 30% of the interspace area. For example, if the interspace depth is 50 mm and the vent is the full width of the window, then the optimal vent would need to be 12-15 mm wide. The experimental literature for similar models demonstrates increasing window height to interspace depth ratios (i.e. larger interspace depths) have limited beneficial effect in terms of buffering heat transfer.⁶¹



The ideal vent positions would be at the top and bottom of the interspace. However, situating the vents on the front surface of the glass, as is generally necessary in practical terms, has minimal detrimental effect on airflow. The most efficient vent design is one that spans the full width of the window and permits flow with limited obstructions. Small vents restrict airflow and generate poorly ventilated recirculating regions where the beneficial heating/cooling effect of the introduced air on the historic glass is lower. This effect can be minimised to some extent by the use of many small vents across the full width of the window. For the same reason, the use of uneven vent shapes and vents protected by mesh are less efficient than simple full width vents. Nevertheless, empirical observation has shown that systems with small and uneven vents function reasonably well in increasing thermal buffering (albeit less efficiently than could be the case) and, therefore, in some applications where more efficient designs are impractical, remain an acceptable approach.

Figure 45. Schematic showing the optimal ventilation gap for a protective glazing system with a 50-mm interspace.

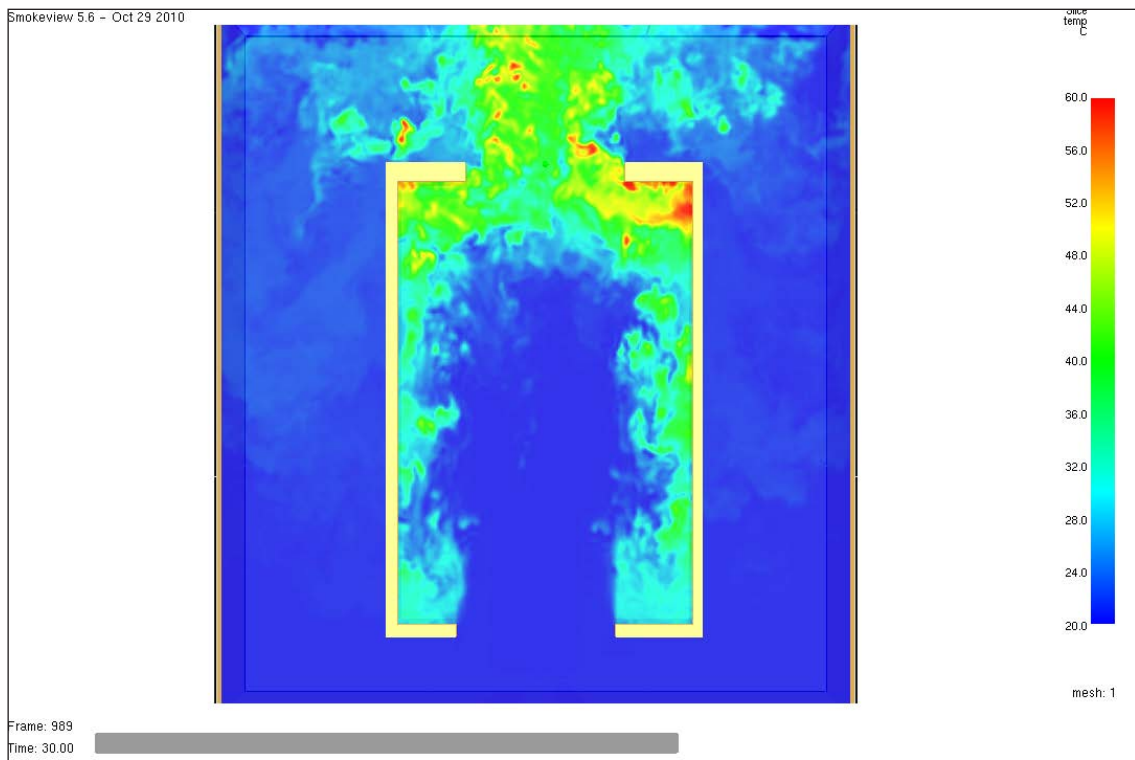
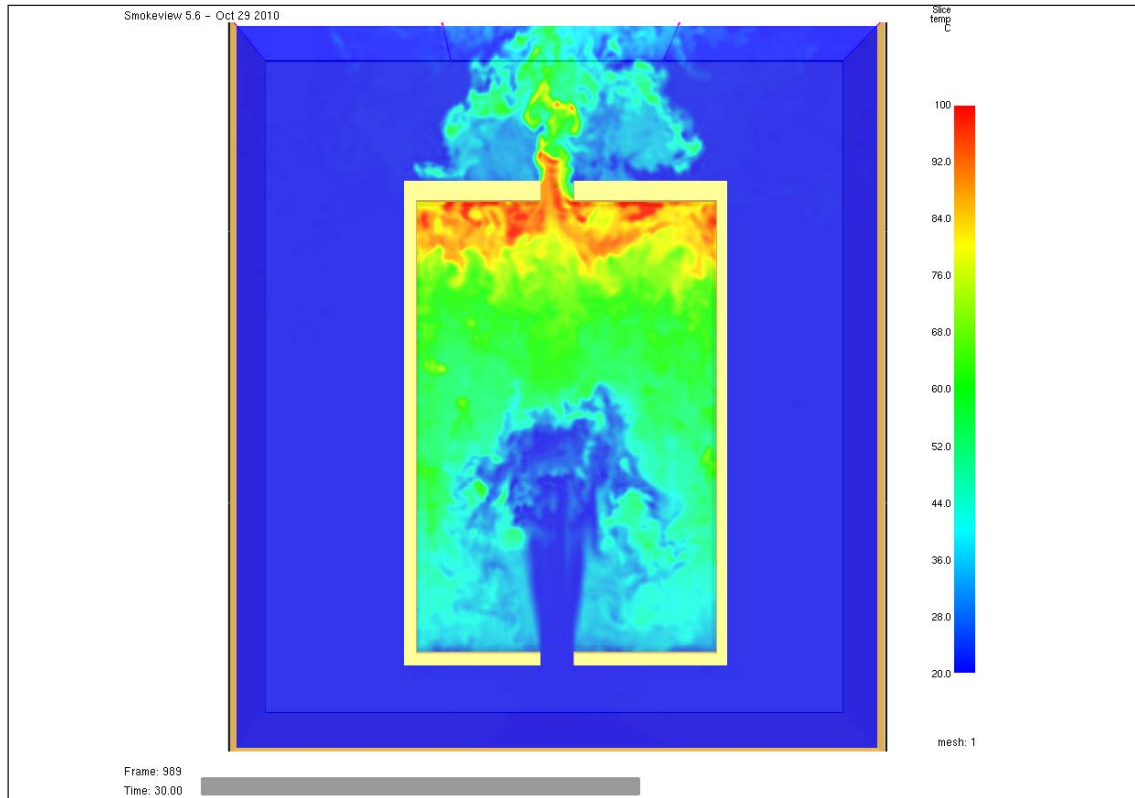

Figures 46, 47. Small full depth vents (top) limit air flow and increase temperature gradients in the interspace whereas larger full width vents (bottom) reduce the temperature differences and vent a significant portion of the window.

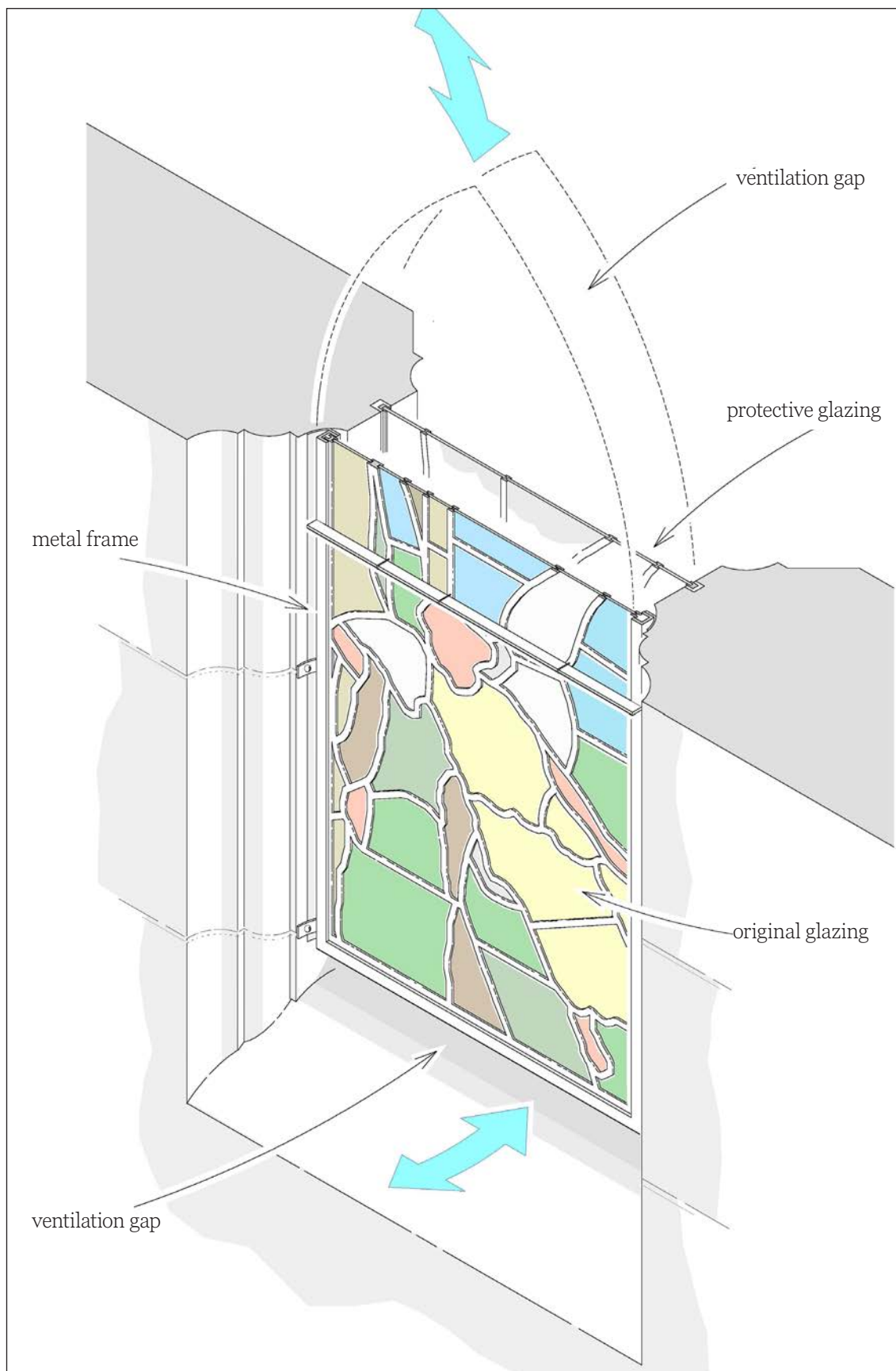

Figure 48a. Internally ventilated EPG designed using a full-width gap at the base and top of the window.

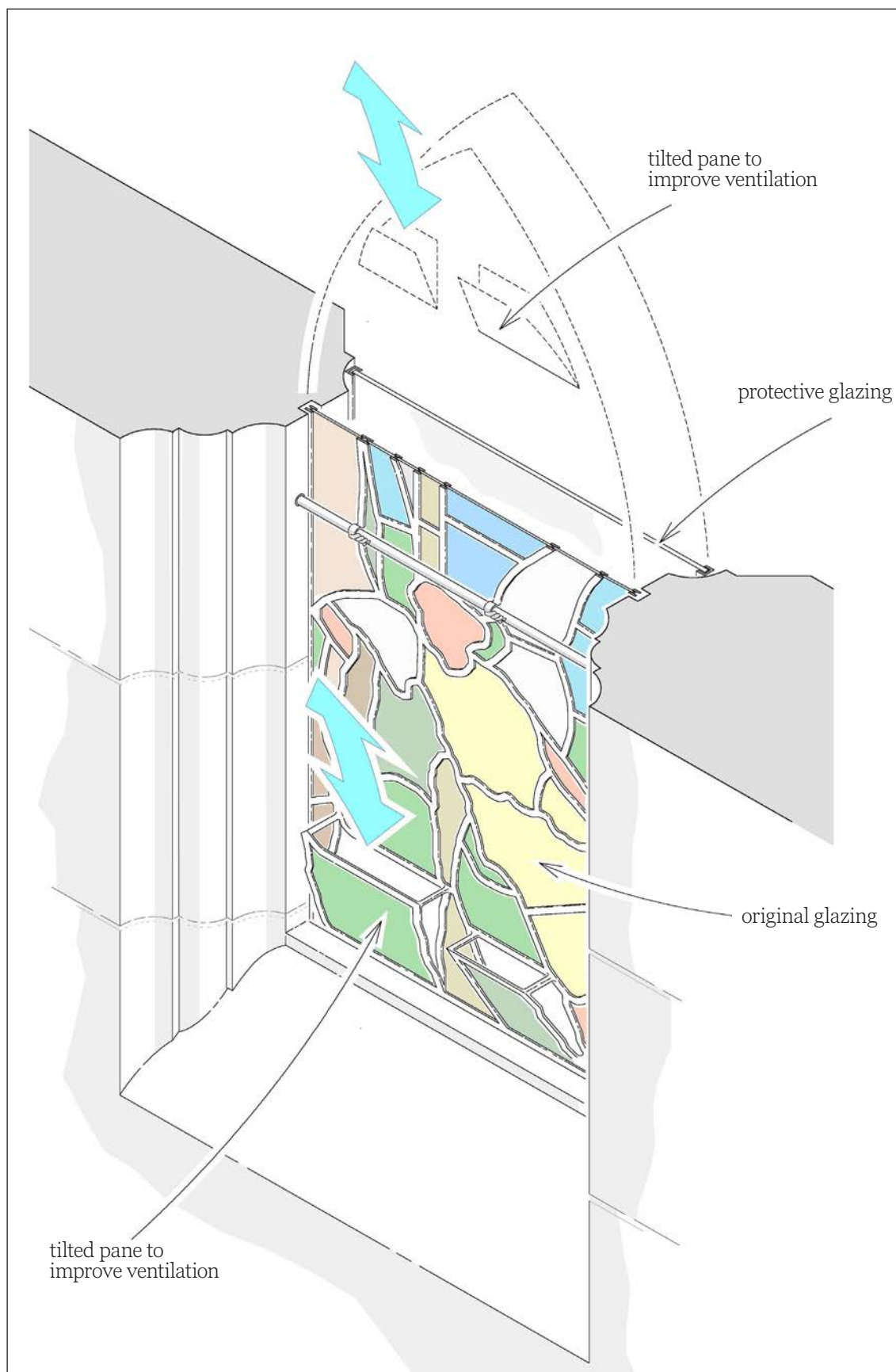

Figure 48b. Internally ventilated EPG designed using openings at the base and top of the window created by tilting out sections of stained glass.

14.2.2 Different Window Sizes

Phase II tested specific variations in window size and geometry to understand the precise impact on the performance of the EPG. One variation was whether the different heights and widths of windows affected the air flow and temperature inside the interspace. The results demonstrate a small difference in temperatures towards the bottom of the inner historic glass. In these cases, the warmer air will be entering from the top vent and cooling as it falls down the window before exiting the lower vent back inside to the church. The cooler areas towards the lower vent are marked in black. Despite the variation in size the temperatures are similar: 11.9°C for the baseline case, 11.8°C for the tall light and 12.2°C for the small light. In each case the dew point temperature was 6°C, meaning in all three cases condensation would be unlikely to form on the historic glass. In contrast as the bottom of the external protective glazing (inside the interspace, rather than outside) the temperatures would be 5.4°C, 5.4°C and 5.7°C respectively and condensation would be expected in all three cases on the protective glazing.

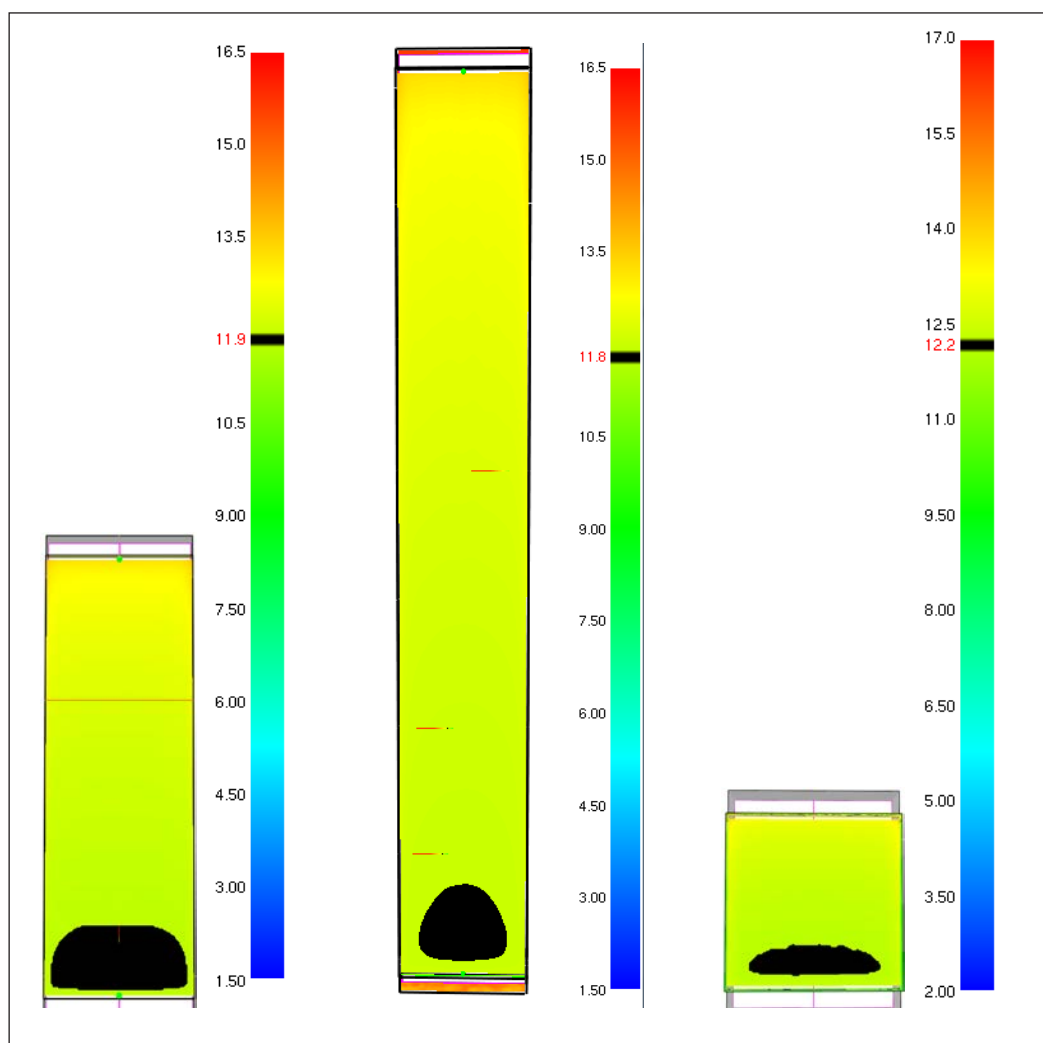

Figure 49. Temperature variations for different geometries of window. On the left: the baseline model; centre: the tall light; and right: the small light.

However, despite the temperature similarities, there were significant differences in the air velocity between the three cases, both at the mid-plane (shown below) and at the upper vent, where speeds were greatest. In the baseline model the typical air velocity was 0.34 ms^{-1} at the vent. There is a large increase in the typical air velocity for the tall light with 1.2 ms^{-1} indicated by the model, but a significant decrease for the small light with 0.18 ms^{-1} at the vent. Greater air flow is thought to increase the rate of evaporation for any condensation. Therefore condensation, on the protective glazing, is likely to evaporate faster in the tall window than on the small window.

Similar results were observed for the smaller interspace depths, with similar temperatures at the lower vent to the baseline case and condensation again predicted to occur on the bottom of the protective glazing but not the historic glass.

For the small interspace (30mm) model there is a minor decrease in the air velocity compared to the baseline model (50mm). However the air velocity is almost halved in the very small (10mm) interspace. The model which included ferramenta showed very small variations compared with the baseline model.⁶²

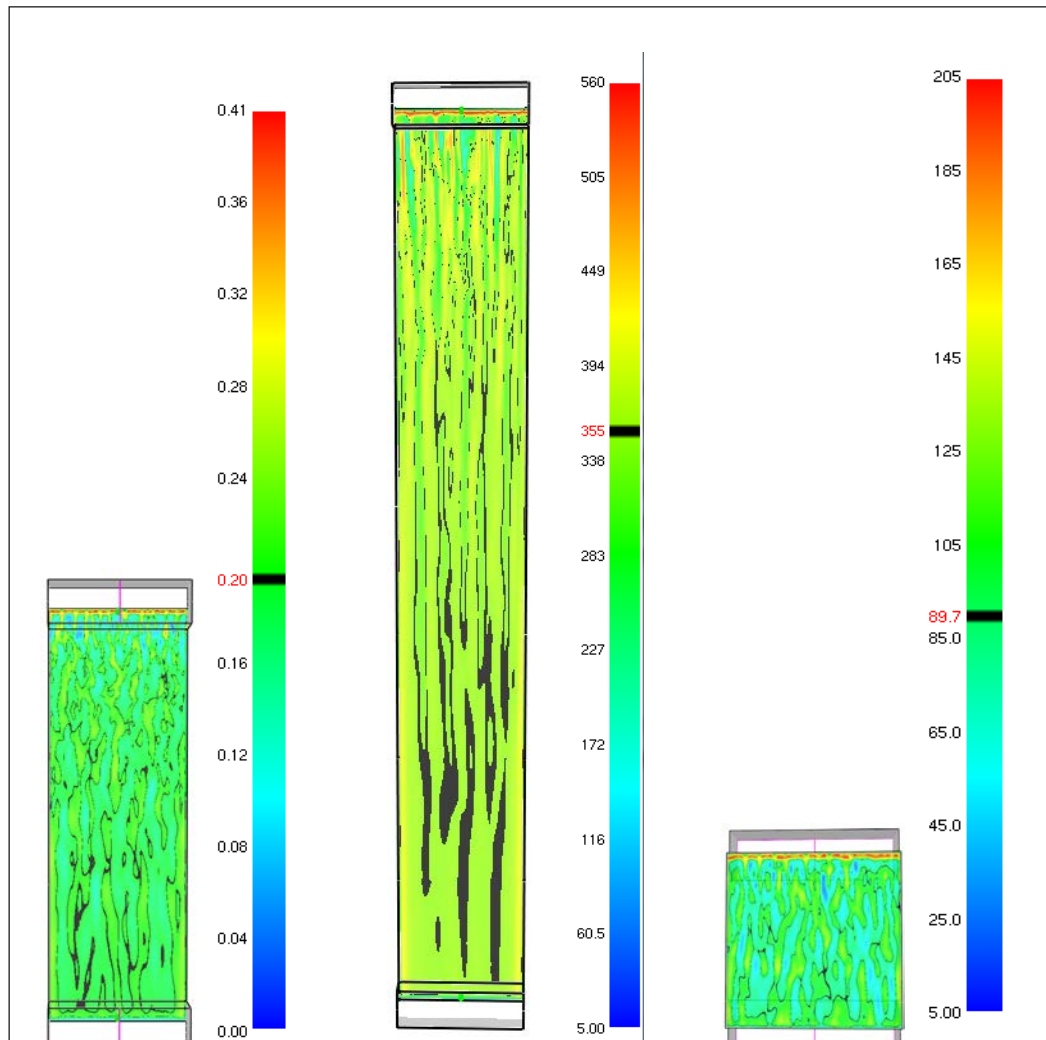

Figure 50. Air velocities for different geometries of window. On the left: the baseline model (scale in ms^{-1}); centre: the tall light; and right: the small light (scale in mms^{-1}).

| Table 14-2. Summary of the Phase II modelling results | | | | | | | |
|-------------------------------------------------------|-------------------------|-----------------------|-----------------------------------|-------------------------------------|-------------------------------------|------------------------------------|----------------------|
| Scenario | units | Dew point temperature | Min. historic glazing temperature | Min. protective glazing temperature | Min. air temperature at vent sensor | Min. air temperature in interspace | Air velocity at vent |
| | | °C | °C | °C | °C | °C | ms ⁻¹ |
| 1 | Baseline model (winter) | 6.0 | 11.9 | 5.4 | 11.0 | 7.9 | 0.34 |
| 2a | Tall light | 6.0 | 11.8 | 5.4 | 10.0 | 7.9 | 1.20 |
| 2b | Small light | 6.0 | 12.2 | 5.7 | 12.5 | 10.1 | 0.18 |
| 3a | Small interspace | 6.0 | 11.7 | 5.3 | 9.5 | 8.0 | 0.28 |
| 3b | Very limited interspace | 6.0 | 11.1 | 4.8 | 6.1 | 6.1 | 0.15 |
| 5c | Ferramenta | 6.0 | 13.0 | 5.5 | 10.9 | 8.6 | 0.32 |
| 4 | Vent to outside | -2.0 | 8.9 | 2.8 | 5.0 | 6.1 | 0.34 |
| | | Dew point temperature | Max. historic glazing temperature | Max. protective glazing temperature | Max. air temperature at vent sensor | Max. air temperature in interspace | Air velocity at vent |
| 5a | Baseline model (summer) | 13.9 | 55.9 | 24.5 | 37.5 | 53.0 | 0.56 |
| 5b | Summer vent to outside | 13.9 | 60.5 | 25.7 | 44.0 | 57.0 | 0.61 |

14.2.3 Seasonal Performance Comparisons

The summer models used higher temperatures inside the building than outside based on the results of environmental monitoring data, which demonstrated that whilst the maximum temperature outside can be greater, in general it remains warmer inside the building, especially overnight when the external temperature will be much lower.

The model predicts greater temperatures on the internal historic glass (max 55.9°C), compared to the external protective glazing (max 24.5°C). However, modelled results were not consistent with monitored results which demonstrate that the average temperature on the historic and protective glazing are similar, but the peak daytime temperature is considerably lower on the historic glass than on the protective glass. This appears to have been caused by no solar absorption being included on the protective glazing in the model.⁶³

Data from Canterbury Cathedral for the same period selected as the model input data recorded protective glazing maximum daytime ST (light green) as 53.8°C and the historic glass (dark green) considerably lower at 39.0°C. Overnight the protective glazing was a similar temperature to the exterior whereas the historic glass remained warmer at a similar temperature to the inside of the building.

For both surface ST the monthly average value is similar, 23.9°C on the internal historic glass and 23.7°C on the protective glazing in the interspace. The similar values demonstrate how averages can mask different diurnal changes, which are much greater on the protective glazing compared to the historic stained glass. Therefore, the scenario sometimes referred to as the 'greenhouse effect' (i.e. significant increase in temperature on the historic glass due to the fact that it is no longer exposed to external air) is unlikely to occur while significant energy is absorbed by the protective glazing.

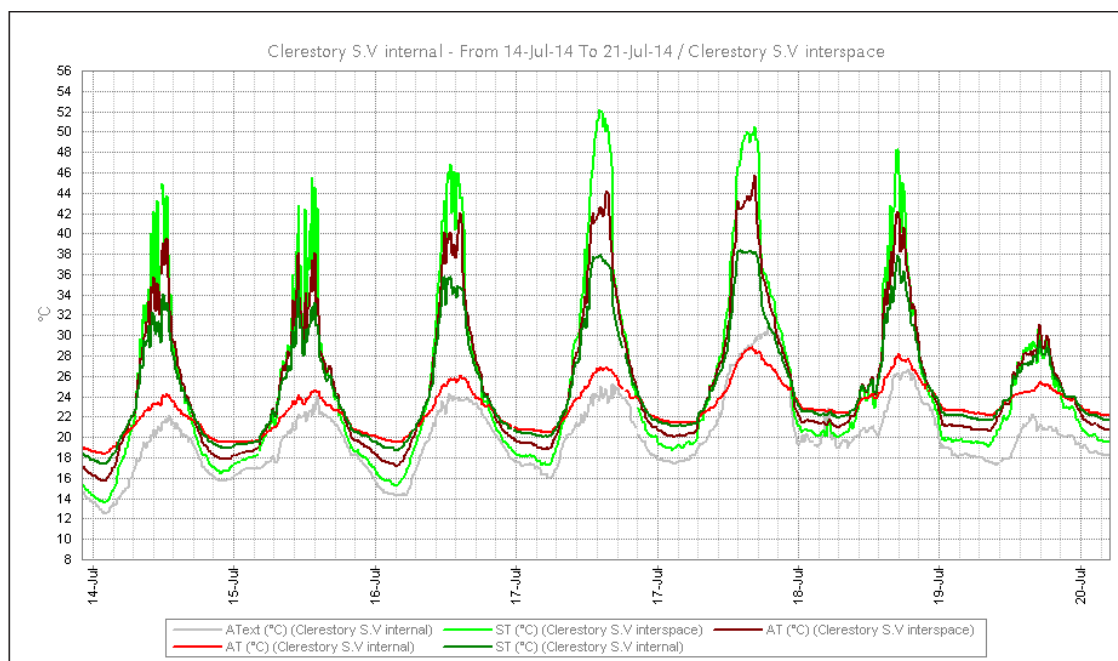

Figure 51. Internal AT (red) often remained above external AT (grey) although the internal ST (dark green) remained cooler during the hottest points than the protective glazing ST (light green) or interspace AT (dark red).

14.2.4 Thermal Efficiency

To determine the impact of protective glazing on energy consumption, it is important to understand its effect on thermal buffering, or the amount of heat lost via the windows. With lower U-values meaning heat loss is reduced and therefore better performance of the windows. For single glazing a U-value of $4.0 \text{ Wm}^{-2}\text{K}^{-1}$ has been used in the building simulation, for reference a typical U-value for double glazing would be $2.34 \text{ Wm}^{-2}\text{K}^{-1}$.⁶⁴

Based on calculations of heat loss from the CFD simulations a U-value of $3.44 \text{ Wm}^{-2}\text{K}^{-1}$ was determined for an internally ventilated protective glazed window. The difference compared to double glazing results mainly from the additional convective heat loss as a result of the ventilation through the interspace. In comparison, the conductive heat loss is reduced as the interspace is warmer than it would be in a sealed double-glazed unit. The ventilated protective glazing provides a slight improvement in the U-value compared to a single glazed window.

However, the proportion of the glazed surface area in a typical medieval building may vary considerably, possibly from less than 5% in a small Romanesque church, to more than 30% in a large Perpendicular building. Therefore, the actual effect on the thermal efficiency of the building will be far lower than the increases in efficiency of the glazing system itself. To test this idea, the model looked at heat loss through the walls, roof, windows, floor and ventilation of the simulated church, constructed of materials common to these buildings. For a late medieval church with larger amounts of glazing the largest heat loss was through the roof, followed by the windows and walls. In the tested model, with a glazing area of approximately 21% of overall internal surface area, the addition of internally ventilated protective glazing to the windows reduces the overall energy use for the church by 3.5%.

For an early medieval church with small windows the greatest heat loss was through the roof, walls, floor and ventilation, with windows providing the smallest amount, even when single glazed. In the tested model, with a glazing area of approximately 2% of overall internal surface area, the addition of protective glazing reduces the overall energy use for the church by 0.4%. These small changes to the building's energy use as a result of protective glazing have also been reported by Wolf et al.⁶⁵ Their experiments and calculations used double glazed protective glazing, but also identified the greatest heat loss was through the roof.

14 PROTECTIVE GLAZING AESTHETICS

The appearance of a protective glazing installation is the most obvious change to a window and the building in which it is situated. The sudden change in appearance and the physical alteration to the fabric necessary to install the glazing must be weighed against the alternative: the slower but far more damaging and irreversible effects of weathering and corrosion on the structural and material state of the historic glazing.

A great number of factors will affect the appearance of a protective glazing system in each individual setting and so no universally applicable design solution can therefore be specified; instead an intelligent, informed, sensitive and creative response to each individual case is necessary.

14.1 Appearance of the External Layer

An important choice that affects the external appearance is how far any visual change is acceptable, because that will dictate whether an ‘honest’ or an ‘integrating’ approach is taken.

14.1.1 ‘Honest’ Approach



The ‘honest’ approach makes no effort to disguise the fact that a second modern layer of glazing has been added, and to accept or even to celebrate the modern addition in its own right. Large sheets of machine-made glass are a functional, relatively low-cost material, and can – as laminate glass – provide very effective protection from impact damage. In addition, this will cause little visual disturbance to the stained-glass window when viewed from inside the building. However, the external change in appearance can be significant.

Figure 52. Patrixbourne, laminate float glass. ©Léonie Seliger

Efforts to make modern float glass less reflective rely on coatings, which have relatively short life spans and may look unsightly as they decay. Some coatings have coloured reflections that add a green or purple tint to the glass surfaces. It is now possible, however, to incorporate mouthblown glass sheets into laminate glass, which helps to soften the reflection of the external glazing.

Other sheet glasses such as mouthblown glass, horticultural glass, drawn glass or kiln-distorted float glass reduce reflections by virtue of a slightly uneven surface. In some cases, the surface appearance of the new glazing is masked by the additional installation of wire guards. If wire guards were already present before the protective glazing was installed, the resulting change in appearance can be minimal.



Figure 53. Cologne Cathedral, Schott low reflective glass. ©Léonie Seliger

Figure 54. Patixbourne, large pieces of mouth-blown glass in combination with wire guards. ©Léonie Seliger

14.1.2 'Integrating' Approach

The 'integrating' approach tries to minimise the visual change that both the window and the building undergo as a whole. The aim here is to provide environmental protection whilst retaining the appearance of a stained glass window from the outside. This can be achieved in a number of different ways.

Since the 1970s, leaded panels have been made to copy a simplified version of the historic lead matrix and thus replicate the iconography of the stained glass from the outside. Exactly how much of the historic lead matrix is copied is a matter of individual assessment for each window. While these panels will need to be maintained to remain water tight, they are easily repairable.

In some cases, leaded panels can be made to follow the divisions of existing external ferramenta, hiding the lead lines behind the ferramenta bars.

An alternative method is to kiln-form large sheets of glass on moulds taken from the surface of the historic stained glass panels, which are hand-painted to reduce reflections and add surface colour. Large flat sheets of glass may also be printed with faded-out photographs of the external surface of the stained glass, including the lead matrix. Both these latter methods require very specific techniques and pose serious questions about repair in the future.

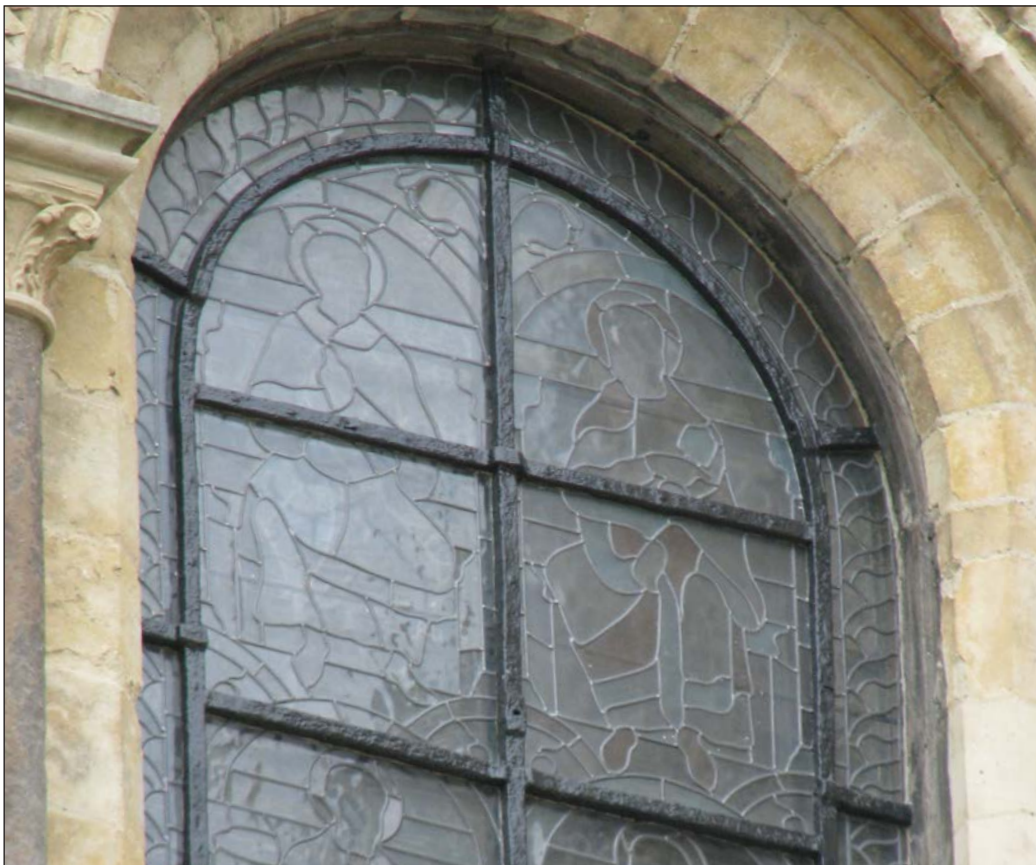

Figure 55. Canterbury Cathedral, kiln-distorted glass, leaded and given a thin coating of glass paint. ©Léonie Seliger



Figure 56. Chartres Cathedral, kiln-formed sheets slumped on moulds. ©Debitus
Figure 57. Long Melford, kiln-distorted glass pieces cut to coincide with ferramenta bars.

14.2 Respecting the Shape of the Stonework

Whichever approach is chosen, the protective glazing must be fitted into the individual openings so that all elements of the stone work remain visible, rather than covering the entire surface of the window. The same principle applies to wire guards. Where laminate glass is employed as the external layer, the more complicated shapes in heads and tracery are often made from plain glass, since laminate glass is very difficult to cut into shapes.



Figures 58, 59. Bad example (top) where the protective glazing covers parts of the stonework; and a good example (bottom) where the protective glazing is fitted into it.

14.3 Other Factors Affecting the Appearance of the External Layer

14.3.1 Functionality

First and foremost, the protective glazing system must function efficiently, which dictates a certain interspace depth and the provision of ventilation openings. This in turn means that there will inevitably be a loss in the depth of reveal, either on the inside or on the outside of the window, and potentially visible gaps to allow air exchange between the interspace and the air inside the building.

Protective glazing can also radically reduce or eliminate UV-light, thus prolonging the life of materials used in the conservation treatment of the historic glass, as well as protecting other artefacts within the building. If this is part of the requirements, laminate glass or UV-blocking mouth blown glass will be the only possible choices.

14.3.2 The Nature and Location of the Stained Glass

Very transparent and delicately painted windows, typical of late medieval or baroque glazing, will allow any additional lines from panel divisions, wire guards, or lead matrices in the protective glazing to be seen through the stained glass.

Richly coloured and densely painted windows will be little affected by a leaded external layer or wire guards. The same applies to windows that are viewed from a great distance rather than from close quarters.



Figures 60, 61. Guards visible through the glazed images.

14.3.3 Parallax

Panel divisions in the protective glazing should always follow existing divisions in the historic glazing or ferramenta / glazing bars to minimise the visual impact. Attempts to eliminate the parallax effect where lead matrices in the protective glazing are visible through the historic stained glass are largely futile. The effectiveness of an adjustment between the external and internal layers is dependent on a single point of view from which the window is seen. However, in reality the window is seen from many different locations and viewpoints. For windows that are exposed to sunshine, the shadow lines on the historic glass will vary according to season and time of day.

14.3.4 Externally or Internally Visible

Protective glazing on windows that are visible from the outside of a building, i.e. those in a cathedral close or churchyard, may require a higher degree of aesthetic integration than on a window that is rarely seen from the outside.

14.3.5 Environmental and Physical Protection Requirements

Where there is a high risk of vandalism or break-in, either laminate safety glass or the addition of wire guards will almost inevitably be required to provide sufficient protection.

14.3.6 Future Repair and Maintenance of the Protective Glazing

Protective glazing solutions that employ elaborately painted or printed surface treatments, or rely on moulds taken from the stained-glass panels to be slumped into, can look aesthetically pleasing. Repairing them in the future, however, might be very difficult or indeed impossible. This could result in a patchwork appearance of the window, and could also add another conservation issue – the protective glazing would in effect become another artefact requiring conservation.

Further details on the choice of materials can be found in English Heritage 2011, but a brief summary is provided in the following table.

| Table 14-1. Considerations when choosing protective glazing | | |
|------------------------------------------------------------------------------------------------------------------------------------------------------|--------------------------------------------------------------------------------------------------------------------------------------------------------------------------------------------------------------------------------------------------------------------------------------------------------------|----------------------------------------------------------------------------------------------------------------------------------------------------------------------------------------------------------------------------------------------------------------------------------------------------------------------------------------------------------------------------------------------------------------------------------------------------|
| <p>New external mounting of protective glazing (internally ventilated system)</p> | <p>Stained glass can remain in original glazing grooves No internal fixings required, hence no changes to the internal window reveals</p> | <p>External reveal depth around windows reduced. External fixings can be visible Vents must be created on internal stained glass (can be less effective due to smaller size and uneven distribution). Creating a reliable weather tight setting for the external glazing is difficult without a glazing groove Air and water leaks into the interspace are possible</p> |
| <p>New external mounting of protective glazing (externally ventilated system)</p> | <p>Stained glass can remain in original glazing grooves No internal fixings required, hence no changes to the internal window reveals No changes to the historic glazing to accommodate ventilation slots</p> | <p>External reveal depth around windows reduced External fixings can be visible Vents in the external glazing provide access for wind-driven rain which can cause new corrosion damages Thermal buffering is not as efficient as internally ventilated systems Creating a reliable weather tight setting for the external glazing is difficult without a glazing groove Air and water leaks into the interspace are likely</p> |
| <p>Protective glazing mounted in original grooves and historic stained glass moved forward internally (internally ventilated, isothermal system)</p> | <p>Original architectural reveal depth at window is preserved externally Ensures ornate tracery is visible externally Easier to create good vent sizes and locate them at the top and bottom of the stained glass panel</p> | <p>Changes internal aspect of window rebate Can lead to halo effect around historic glass unless skirts (or wider frames) are provided Mounting frame visible on low windows Where historic window furniture such as ferramenta remain in position, the historic glazing and the historic ferramenta will be divorced</p> |
| <p>Double groove in stonework</p> | <p>Some architectural reveal depth can be retained both internally and externally Ensures ornate tracery is visible on both sides Permits weathertight installation Both sides are still installed into the stonework, retaining an authentic look No halo effect No need for frames</p> | <p>Only suitable for mullioned windows set into stone (not early medieval ferramenta frames) Only suitable for stonework with considerable depth Airflow is slightly impeded by having to travel around stonework, rather than flowing straight up Constitutes significant change to the stonework</p> |
| ARCHITECTURAL CONSIDERATIONS | | |

Table 14-1. Considerations when choosing protective glazing

| GLAZING CONSIDERATIONS | |
|-----------------------------------------------------------------------------|---------------------------------------------------------------------------------------------------------------------------------------------------------------------------------------------------------------------------------------------------------------------------------------------------------------------------------------------------------------------|
| Plate / float glass | Cheaper raw material Good light transmission |
| Coated float glass | Can reduce reflectivity |
| Horticultural glass | Very cheap raw material Good light transmission Softens reflections |
| Kiln-distorted | Softens reflections Can often be produced from float or horticultural glass Can be textured further with sand or grog clays |
| Hand blown | Softens reflections |
| Slumped | Follows pattern and shape of stained glass panel, softening reflections and mimicking surface textures and patterns, including lead lines Single piece of glass, so forms better barrier compared to leaded panels |
| Leaded | Breaks up external expanse of glass, reducing reflections, especially for plate/float glass Gives impression of stained glass design Minor damages can be easily repaired <i>in situ</i> Reflections can be further reduced by kiln distorting and application of thin fired oxide paints |
| Laminated | Provides good impact protection Reduces UV light by 99% |
| Plastic | Cheap Light Good initial light transmission Good impact protection |
| Applied Coatings (on protective glazing) | Can reduce UV transmission initially Can reduce glare or reflections initially |
| Restaur@ UV glass (mouthblown glass with UV filter built into glass matrix) | Eliminates UV light completely and permanently Can be made into leaded lights |
| Metal mesh | Comparatively cheap Provides impact protection |
| | Often highly reflective (but can be acceptable if hidden from view) |
| | Relies on coatings, must be handled very carefully during installation and has limited life span |
| | Can look dull |
| | Size of sections limited by the kiln size |
| | Expensive Only available in relatively small sections |
| | Requires stained glass panel to be removed to create a mould or tracing Taking a mould of the historic glazing can be unacceptably stressful to a fragile panel Expensive If painted to match stained glass panel, can reduce light transmission Repair or replacement will be costly, and may be impossible without repeating the mould-making process |
| | Not suitable for very transparent stained glass - creates shadows when viewed internally (parallax) Requires periodic maintenance as any stained glass window, otherwise will allow air and water infiltration after several decades, reducing efficacy |
| | Expensive Heavy Even 'non-reflective' laminate can have significant surface reflections Not suitable for shaped tracery panels due to difficulty in cutting curves |
| | Can yellow or become opaque with time Scratches easily Can warp and look very unsightly, especially on south side Will require replacement periodically |
| | Expensive Rapidly deteriorate, leading to flaking, bubbling or peeling of coating Difficult to remove or replace |
| | Expensive |
| | No environmental protection Creates significant shadows behind the stained glass when viewed internally |

14.4 A Temporary Reversible Measure?

In principle, the addition of protective glazing is seen as a temporary measure, which must be designed to be as reversible as possible. This, however, presupposes that either environmental conditions will improve to a point where corroded and aged glass and painted decoration are not in danger of further damage, or that some alternative way can be found that will permanently and reliably protect the stained glass from environmental deterioration.

The reality is that once corrosion has set in, the deterioration of historic stained glass will not stabilise without environmental protection. Equally, the development of a reliable, durable, non-harmful and re-treatable artificial coating, once the holy grail of conservation science, has effectively been abandoned after decades of failed experiments. Therefore, once protective glazing is installed, it is very likely to only be replaced with an improved version of itself – be it in terms of functionality or in terms of aesthetics. It is also likely to require maintenance and repair.

15 LIGHT TRANSMISSION

One frequent question in relation to the use of protective glazing is the impact it will have upon transmitted light levels from the inside. Particularly when a test panel of protective glazing has been added to a single light and is seen to appear darker from inside compared to the surrounding lights. However, when all lights have protective glazing added, the comparative darkness effect disappears.

Most plain float glass has a high level of light transmission; however this also creates unwanted reflections on the external face impacting on the building's external appearance. To limit the external reflections the glass can be distorted or painted as discussed above, however this may also reduce the transmitted light, making it seem darker inside.

Systematic measurement of light transmission from protective glazing is complex due to the irregular characteristics of different types of glazing and the fact that some incorporate non-transmissive materials including lead cames. Tests using HDR photography were undertaken as part of the present study but results were inconclusive.⁶⁶ Although it was demonstrated that a reduction in transmission is observed with some types of protective glazing did occur the precise levels were complicated by a large number of variables which occur in real installations. In practice, any light loss caused by the actual modern glazing is often made up for by the fact that the historic glass is cleaned at the same time as the installation of the glazing, and historic light-suppressing protection removed, with the effects that the transmission properties of the window in fact improve.

16 CONCLUSIONS

To many observers historic stained glass, viewed from a distance with transmitted sunlight, appears stable and unchanging. When change happens, as it inevitably does, it is slow and can be barely perceptible to the observer. However, close examination of many historic stained-glass windows shows that they have suffered significant deterioration in the past and, in many cases continue to do so, with the result that irreplaceable figurative detail is lost and, in some cases, the windows become structurally unstable. This is unsurprising given that the glazing forms the interface between the internal and external environments both of which can be highly aggressive.

Externally, wind loading and pressure variations can cause structural deformation and direct rainfall and pollution can cause chemical damage to the glass body as well as any external applied paints. Internally, where most of the sensitive painted and applied layers exist, condensation is the greatest agent of decay causing both the dissolution of the soluble fraction of the glass as well as delamination and flaking of weak paint and enamel layers. This can be exacerbated by chemical pollution and microbiological attack.

In most cases, because of the nature of the glazing as part of the building envelope, there are limited measures which can be implemented in order to improve the background environmental conditions in the building to the extent that deterioration of the stained glass can be prevented. Therefore, in cases where the environmental deterioration of the glass is such that mitigation measures are necessary, the only approach which can control the underlying causes of deterioration, while allowing the glass to remain in place, is environmental protective glazing (EPG).

While systems of EPG have been in use since the 19th century it is only in the latter part of the 20th century that more detailed studies have been undertaken into its functionality in order to understand how better designs can be developed. However, such work has been limited and the approach is often to install a design which is aesthetically acceptable rather than examining optimal functionality.

The current study has allowed a review of the existing state of knowledge of EPG systems and undertaken a series of pieces of research allowing an understanding to be developed of the influence on functionality and performance of different design elements alongside the aesthetic considerations which are an essential part of any successful conservation project.

The results of environmental monitoring of numerous installations has shown that all well-designed secondary glazing systems will provide a level of mechanical protection of some degree to the historic glass over which they are installed. They also provide a level of protection from wind loading and driving rain although in the case of externally ventilated systems there may be some residual influence if water and wind entering through large ventilation openings. Some level of protection from pollution, particularly for internally ventilated systems will also be provided in most cases.

Both the published literature and the results of numerous studies undertaken by the author, including those case studies which form part of the current report have demonstrated that protective glazing provides a significant increase in thermal buffering for the historic glass reducing the risk of condensation. Internally ventilated systems have been shown to provide a greater level of buffering than externally ventilated systems. The latter still provide significant protection but carry with them the risk of water penetration into the interspace.

What is clear from a number of the case studies is that the background environmental conditions in the building are a critical part of the functionality of the protective glazing system. This is unsurprising as the air which interacts with the boundary layer in front of the glass is part of the air mass of the building as a whole. Therefore, the condition of the building envelope, the rainwater disposal system and artificial influences such as heating and building use, all have a direct influence on the environmental conditions to which the internal face of the historic glass is subjected and therefore the conditions which the EPG is attempting to modify. It is thus essential that the environmental deterioration of the stained glass and the functionality of the protective glazing system is seen within the context of the building environment as a whole rather than as an isolated 'window related' issue.

In studies carried out in recent years, the protective glazing systems which were seen to offer the least protection to the historic glass and allow the highest level of condensation were not those with severe design limitations but were those which were installed in churches with unusually high levels of RH as a result of building defects and badly designed heating and ventilation practices. In all of the cases examined the actual design of the protective glazing was satisfactory and in average RH conditions would have provided a high level of condensation protection. In practical terms this means that the stained glass conservator needs to work in close collaboration with the building architect and owner to ensure that the building conditions are satisfactory rather than assuming that the protective glazing system alone will entirely protect the historic glass from environmental deterioration.

The CFD modelling carried out as part of the present study has shown, what is apparent from anecdotal evidence, that the geometry of the secondary glazing system, and in particular the interspace depth and vent size and design, have a significant impact on the rate of airflow through the system and therefore the level of thermal buffering provided. Although the system is quite robust (even badly formed vents and unduly thin interspaces provide considerable thermal buffering) to provide the best level of buffering, vents should be full width at the top and bottom of the windows and no less than one third in height of the depth of the interspace. In other words, for a 60 mm interspace, the optimal vent should be full width and no less than 20 mm high.

The interspace depth itself can vary considerably and the commonly used vent depth of between approximately 40 and 60 mm is adequate in most cases. However, very small interspace depths (for example, 10mm and below) were shown to reduce functionality. The topography of the interior faces of the interspace also influences functionality although it appears that periodic restrictions such as ferramenta have only limited effects.

It would be possible to refine the models and test numerous different protective glazing geometries. However, as each real world case will vary due both to the architectural context and the design and condition of the historic glass, it will never be possible to provide standard design details which will optimise the functionality and performance of every installation. Rather, it is important that practitioners understand the principles involved and the different influences that the individual design variations may have.

An assessment of the effect of protective glazing on heat loss characteristics in the building as a whole was also undertaken in order to investigate possible benefits in energy efficiency of EPG. The results demonstrated that while ventilated secondary glazing provides a significant increase in U value over single glazing, even in the case of large windows in late medieval buildings, the proportion of overall surface area is comparatively small. Therefore, the improvement in the overall heat loss characteristics of the building as a whole is limited. That is not to say that some benefit is not provided but this is generally dwarfed by the effects of the performance of other building elements including uninsulated roofs.

The aesthetic impact of glass deterioration and the permanent loss of figurative details is often overlooked due to the comparatively slow speed at which it takes place. Rather, the focus is generally on the short term aesthetic impact of the protective glazing system itself. This is unquestionably significant and therefore needs to be carefully addressed when considering any intervention.

At the outset, it is important to note that, in most cases, protective glazing is a fully reversible system and therefore if fashions and technology change in the future it can simply be removed. However, this is in the very long term and probably outside the lifetime of those practitioners and clients considering the conservation of the glazing. Therefore, it is important that aesthetic effects of protective glazing both on the building and on the stained glass itself are carefully considered. Various approaches have been discussed, all of which have a range of advantages and disadvantages as well as installation and maintenance costs. Inevitably, each case will need to be considered individually and the protective glazing system designed accordingly. However, in all cases, it is critical that the functionality of the system leads the design and that aesthetics, while of huge importance, do not compromise this.

In conclusion, it should be restated that the current study is intended to provide an overview of the state of knowledge of protective glazing and to give a more detailed insight into both functional and aesthetic issues. It is not the intention of this document to offer a set of rules or standard design details. Rather, the aim is to provide practitioners and clients with the terms of reference in order to design functionally effective and aesthetically acceptable protective glazing systems in order to control the loss of irreplaceable historic stained glass.

17 GLOSSARY

Alkali glass

Glass made using potassium or sodium carbonate (both alkaline materials) as the flux.

Blown glass

Traditional method of creating glass, using a blowpipe to inflate a ball of molten glass, which is then shaped and formed into a flat sheet (see cylinder glass and crown glass).

Bulk glass

Used to describe the main body of the glass material, which is unreacted, compared to the leached surface layer, can sometimes also be referred to as the glass matrix.

Bull's eye glass

Refers to a pane of glass cut from the central part of large crown glass panes and containing the mark (bull's eye) from being attached to the glass blower's punty.

Cames

Grooved, often H-shaped in cross section, piece of metal (usually lead), used to join separate sections of glass in stained glass or quarry glass.

Carnation red

Also referred to as Sanguine, this is the thin, iron oxide layer applied to the internal or external surface of the glass, resulting in a red colour.

Cold paints

Paint, often oil paint, which is used to decorate glass, or for retouching missing areas. There is no chemical bond between the glass and the coloured layer, making it vulnerable to loss.

Condensation

Formation of water droplets on a cold surface from the surrounding humid air.

Corrosion

Dissolution of the glass network; occurs at higher pHs.

Corrosion pits

Localised corrosion possibly formed due to particles on the surface concentrating leaching reaction by attracting moisture. As the alkali is leached from the glass surface, the solution pH increases and the glass network is attacked, forming pits as this process moves through the glass.

Crizzled

Characteristic network of cracks in the glass due to atmospheric moisture attack.

Crown glass

Sheet glass made by blowing glass, which is then cut open and rotated and reheated repeatedly to create a flat disk.

Cylinder glass

Made by inflating glass and swinging to form a cylinder, which is removed from the glass blower's pipe and cut lengthwise, reheated and flattened to form a flat sheet to be used as window panes.

Dew point

The temperature at which condensation will form (pressure remains constant).

Enamels

Used to decorate glass, made from finely powdered glass, which has been coloured with metallic oxide pigments and combined with oil to be used as paint, before being fired. This burns away the oil medium and melts the powdered glass, bonding the enamel to the surface.

Environmental monitoring

Comparison of long-term trends in environmental conditions (such as temperature, light, humidity) to determine relationships between different rooms or zones within a building.

Environmental survey

Assessment of building performance using spot measurements and visual inspection.

Externally ventilated

Protective glazing that is open to the outside, providing external air to ventilate the space between the stained glass and protective glass.

Ferramenta

Ironwork in front of stained glass windows; provides support.

Flaking

Areas, often of painted detail, which are lifting from the surface and falling away. When used in relation to glass decoration, can lead to clear areas of glass within painted details of the stained glass.

Flashed glass

Thin surface layer of strongly coloured, often red, glass on a clear piece of glass to improve light transmission through the strong colour.

Float glass

Process of creating large sheets of flat glass by floating molten glass on a bed of molten metal, often tin. Used to produce most modern window glass from the 1960s onwards.

Flux

Substance added to lower the melting temperature, e.g. potash to lower the silica melting temperature.

Glass matrix

Used to describe the network of silica that primarily forms glass; can be used as a synonym for the main body of glass.

Grisaille

Method of painting to create monochrome black and grey decoration on stained glass. Can also be used in relation to brown and dark red paints used to define details in the stained glass window.

Hydration layer

See Leached layer.

Impact protection

External layer used to prevent stained glass (or windows in general) from being broken; often made of metal mesh or plastic sheet; offers no environmental protection to the stained glass.

Internally ventilated

Protective glazing that is open to the inside, providing internal air to ventilate the space between the stained glass and protective glass.

Interspace

The space between the stained glass and protective glazing layer.

Isothermal glazing

Protective glazing installed into original glazing grooves, with stained glass framed and mounted inside. The term indicates that the stained glass is at the same temperature (isothermal) as the room, however in reality room temperature and glass surface temperature are rarely identical.

Kiln distorted glass

Plate glass that has been heated in a kiln to distort the pane, making it less flat. This reduces the reflections when used as protective glazing.

Laminated glass

Two layers of glass with a plastic layer sandwiched between them, this holds the glass together when it breaks, commonly used as a safety glass.

Leached layer

Very thin surface layer of glass that has been exposed to water (liquid or vapour), which has removed (leached) the alkali (sodium, potassium, calcium or magnesium) ions and replaced them with hydrogen ions from the water. In most glasses this is a slow process, forming a protective layer that prevents further leaching. However, in low durability glasses cracks form in the leached layer allowing further water penetration and thus further leaching to take place.

Leaded

Window panes framed with lead, including stained glass and quarry glass. In relation to protective glazing, leaded refers to traditionally made panels using individually cut pieces of glass held together with lead cames. The new protective glazing usually follows the historic lead matrix in a simplified design.

Metal oxide paint

See Grisaille.

Microfractures

Very small cracks in the glass, often invisible to the naked eye, which develop over time leading to visible cracking and loss of painted details.

Mixed ventilation

Protective glazing that is open to both the inside and the outside, providing air to ventilate the space between the stained glass and protective glass. Relatively rare construction method.

NO₂

Nitrogen dioxide, common gaseous pollutant, often found in areas with high levels of traffic, e.g. close to busy roads.

O₃

Ozone, common gaseous pollutant, often higher in rural areas.

Plate glass

Flat glass formed by rolling molten glass on a metal plate, before grinding and polishing the surfaces. Not commercially produced since the 1960s.

Potassium-rich glass

Alkali flux used in the glass mix comes from potash giving a glass composition with high levels of potassium and other alkalis. Also referred to as forest glass, in the medieval period potash came from burnt plant sources.

Protective glazing

Generic term applied to secondary glazing system, which is designed to prevent further deterioration of the stained glass.

Quarry glass

Small panes (usually diamond shaped) connected to many others using lead cames, to create a panel large enough to fill the window.

Reflection

When light bounces back off a surface, rather than travelling through it. In the case of protective glazing it often refers to the images of the surrounding external environment, such as trees and nearby buildings, seen in the modern glass of the protective glazing.

RH

Relative humidity; is the amount of water in the air divided by the maximum amount of water that the air can hold at that temperature, expressed as a percentage.

Sanguine

See Carnation red.

Secondary glazing

Used to describe glazing systems where a second pane (usually of glass) is added.

Silver stain

Application of silver nitrate or similar silver compounds to the surface of the glass before firing at a low temperature, to produce a yellow colour. Can range from pale yellow, right through to brown in colour.

Slumped glass

Heating glass until it softens into a mould. In protective glazing the mould can be made from the original stained glass window, so the final protective glazing has the same profile.

SO₂

Sulfur dioxide, common gaseous pollutant, often found in areas with high levels of industry. Regulations on the quality of air have led to falling levels in the last 50 years.

Stack effect

Air movement driven by differences in temperature, leading to changes in the air density and buoyancy. Warm air rises, reducing the pressure at the base and drawing in colder air, whereas cold air will sink. In protective glazing systems the stack effect ensures air circulates through the interspace.

Stained

Metal oxide pigments mixed in clay and applied to the surface of the glass before firing, which transfers the colouring ions into the upper surface of the glass.

Stained glass

Generic name for decorative windows, often made from coloured glass. However glass is not always strictly stained, it can also be coloured by the addition of pigments to the glass mix, painting with enamel, and flashing.

Thermal shock

Large and rapid temperature changes, leading to stresses forming in the material and causing cracking.

Transmission

Light passes through the material. Glass is primarily observed in transmission, unlike most other materials. The colour of the transmitted light is affected by the absorption of the stained glass.

Unventilated

Glazing system that has no ventilation through the interspace; rare in protective glazing for stained glass, however commonly used in double glazing (with the interspace fully sealed and filled with an inert gas).

UV

Ultraviolet radiation; causes fading reactions and yellowing of materials, but not required to see objects, therefore often removed from internal collection spaces by the application of UV absorbing films to windows.

Ventilation gaps

Spaces usually at the top and bottom, but can be located on the stained glass panel, by moving forward individual pieces of glass, which allow air to enter the interspace and provide ventilation.

Weathering crusts

Deposits that have formed on the external surface of the stained glass, often when the leached alkali ions react with other gaseous pollutants.

Yellow stain

See Silver stain.

18 ENDNOTES

- 1 Muller 2000
- 2 The term Environmental Protective Glazing or EPG is used in this research to define a protective glazing system the primary purpose of which is to modify the environmental conditions to which the historic glazing is exposed. This is intended to differentiate systems of this type from those intended primarily to provide physical protection.
- 3 English Heritage (now Historic England) 2011, 281-312
- 4 For further information on glass composition see Freestone 2008
- 5 Geotti-Bianchini 2005
- 6 Woisetschläger 2000
- 7 Cummings 1998. To allow the effects of RH to be evaluated within a relatively short period of time, dosimeters were developed using low durability soda-lime glass as a proxy for all alkali-silicate glasses (such as medieval glass).
- 8 Walters 1975
- 9 Cummings 1998
- 10 The effect of this type of failure mechanism on vulnerable paint and enamel layers has received very little study.
- 11 Walters 1975
- 12 Ionescu 2012
- 13 Becherini 2008
- 14 Van der Snickt 2006
- 15 Schalm 2009
- 16 García-Heras 2006
- 17 Barley 2010
- 18 Bettembourg 1994
- 19 Drachenberg 1988
- 20 Isothermal gazing is a term generally used for an internally ventilated system.
- 21 Trumpler 1988
- 22 Femenella 1996
- 23 Newton 1980
- 24 Gilberg 2002
- 25 Bacher 1980
- 26 Bacher 1976
- 27 Patronis 2002
- 28 Bettembourg 1994
- 29 Oidtmann 2000
- 30 Newton 1975
- 31 Oidtmann 2000
- 32 Newton 1975
- 33 Patronis 2002
- 34 Tobit Curteis Associates have undertaken a wide range of studies in the UK including studies at Canterbury Cathedral, Exeter Cathedral, Winchester Cathedral, Kings College Chapel, Cambridge, and numerous parish churches.
- 35 Bernardi 2013
- 36 Bernardi 2005

- 37 Tobit Curteis Associates 2011
- 38 Bernardi 2005
- 39 Kontozova-Deutsch 2008
- 40 Bernardi 2006
- 41 Bernardi 2013
- 42 Tobit Curteis Associates 2011
- 43 Bernardi 2013
- 44 See <http://www.isac.cnr.it/vidrio/index2.htm> for details (accessed 25/4/18)
- 45 Godoi 2006
- 46 Kontozova-Deutsch 2008
- 47 Kontozova-Deutsch 2011
- 48 Kontozova-Deutsch 2005
- 49 Léonie Seliger, pers comm
- 50 Fuchs 1993
- 51 Fuchs 1991
- 52 Romich 2004
- 53 Melchar 2004
- 54 Condensation shown in the charts is calculated as (ST-1)-DPT in order to allow a significant margin of error.
- 55 It is likely that conditions will vary from those monitored, particularly on large or tall windows.
- 56 The published accuracy levels for the probes are SHT77RH +/- 2%, AT +/- 0.2°C. EU-U-V2, ST +/-0.2°C, EE66 +/-0.04m/s +2% of m.v. (0-1m/s). EE66 sensors are bidirectional with an angular dependence of <3% of measurement at $|\Delta\alpha|<10^\circ$.
- 57 Paraloid B72™ is an acrylic resin considered to be among the most stable conservation adhesives.
- 58 Details on the software and download for the code can be found on <https://code.google.com/p/fds-smv/> (accessed 05/12/2014)
- 59 Slater 2014
- 60 ibid
- 61 Sparrow 1985
- 62 The ferramenta in the model was relatively small and so appears to have had limited effects on flow rates at the vents, although over the ferramenta itself, rates would have increased. It is likely that if the ferramenta was larger and reduced the interspace depth more significantly (as with the 10-mm interspace model) the impact would be greater.
- 63 Having reviewed the modelled results it was seen that the model applied solar absorption to the historic stained glass, due to its coloured nature and not to the protective glazing as this was considered to be clear. Had solar absorption of the protective glazing been added along with the effects of lead comes and ferramenta, results may well have been similar to those obtained by monitoring.
- 64 *Element Energy* 2014
- 65 Wolf 2013
- 66 Luxford 2014

19 BIBLIOGRAPHY

- Anderson, D 1996 'Stained glass and its decay'. *The Conservation and Repair of Ecclesiastical Buildings*. Tisbury: Cathedral Communications Limited; available online at: <http://www.buildingconservation.com/articles/glassdecay/glassdecay.htm>
- Bacher, E 1980 'The decay of mediaeval stained glass: climatic and environmental influences' in Brommelle, N.S., Thomson, G., Smith, P. (eds.) *Conservation within historic buildings Preprints of the contributions to the Vienna Congress, 7-13 September 1980*. London: IIC, 87-88
- Bacher, E 1988 *Newsletter Technical Committee Corpus Vitrearum International* 41/42; available online at: http://cvi.cvma-freiburg.de/documents/newsletter/CVMAnewsletter41_42.pdf
- Bambrough, M 2005 'Aesthetic protective glazing', in *Historic Churches*, Tisbury: Cathedral Communications Limited; available online at: <http://www.buildingconservation.com/articles/aestheticprotective/aestheticprotective.htm>
- Barley, K 2010 'A history of protective glazing', in Husband, T, Piloni, L, and Shepard, M (eds.) *The art of collaboration: stained glass conservation in the 21st century*, Washington: Harvey Miller, 111-118
- Becherini F *et al* 2008 'Thermal stress as a possible cause of paintwork loss in Medieval stained glass windows'. *Studies in Conservation* 53: 238-251
- Bernardi, A, and Becherini, F 2004 'Conservation of stained glass windows and microclimate: a comparison between different protective glazing systems' *IAQ*; available online at: http://www.isac.cnr.it/iaq2004/posterabstract/bernardi_poster_abstract.pdf
- Bernardi, A *et al* 2006 'Condensation on ancient stained glass windows and efficiency of protective glazing systems: two French case studies, Sainte-Chapelle (Paris) and Saint-Urbain Basilica (Troyes)' *Journal of Cultural Heritage*, 7: 71-78
- Bernardi, A *et al* 2012 'Conservation of stained glass windows: an innovative user-friendly portable device coming from the EU-VIDRIO project' *Journal of Environmental Science and Engineering B* 1:519-526
- Bernardi, A *et al* 2013 'Conservation of stained glass windows with protective glazing: main results from the European VIDRIO research programme', *Journal of Cultural Heritage*, 14:527-536
- Bettembourg J M 1980 'Climatic factors and corrosion of stained glass windows' in Brommelle, N S, Thomson, G, Smith, P (eds.) *Conservation within historic buildings Preprints of the contributions to the Vienna Congress, 7-13 September 1980*, London: IIC 93-95
- Bettembourg, J M 1994 'Preventive conservation of stained glass windows' in Roy, A, Smith, P (eds.) *Preventive conservation: practice, theory and research. Preprints of the contributions to the Ottawa Congress, 12-16 September 1994*, London: IIC, (1994) 110-115
- Clare, S 2013 *Stained Glass: Art, Craft and Conservation*. London: Hale Books
- Cummings, K *et al* (1998) 'Weathering of glass in moist and polluted air', *Nuclear Instruments and Methods in Physics Research B* 858-862
- Curteis T and Luxford N 2014 'Protective glazing'. *Historic Churches*. Tisbury: Cathedral Communications Limited available online at: <http://www.buildingconservation.com/articles/protective-glazing/protective-glazing.htm>
- Drachenberg, E 1988 'Les vitrages protecteurs en R.D.A.' in *Newsletter Technical Committee Corpus Vitrearum International* 41/42. Available online at: http://cvi.cvma-freiburg.de/documents/newsletter/CVMAnewsletter41_42.pdf (accessed 25/4/2018)

- Drewello, U *et al* 2000 'Biogenic surface layers on historical window glass and the effect of excimer laser cleaning'. *Journal of Cultural Heritage* 1:S161-S171
- Element Energy 2014 'Ventilated protective glazing: analysis of performance and impact on energy efficiency: a report to English Heritage and Tobit Curteis Associates', 4th December 2014
- English Heritage (now Historic England) 2011, Pender R, and Godfraind, S (eds.), *Practical Building Conservation: Glass and Glazing*. Farnham: Ashgate/Routledge
- Femenella, A J and Simon, W 1996 'Conservation issues of protective glazing' in Gilberg, M. (ed.) *Protective Glazing Study*, U.S. National Park Service, Report Number 1996-06, 90-108. Available at: <https://ncptt.nps.gov/wp-content/uploads/1996-06.pdf> (accessed 25/4/2018)
- Freestone, I C, Hughes, M J. and Stapleton, C P 2008 'The composition and production of Anglo-Saxon glass' in *Catalogue of Anglo-Saxon Glass in the British Museum*, London: British Museum, 29-45. Available at: <https://www.britishmuseum.org/pdf/2%20Composition%20and%20Production%20ed%20bibliog.pdf> (accessed 25/4/2018)
- Fuchs, D R *et al* 1991 'Glass-sensors: assessment of complex corrosive stresses in conservation research'. *Materials Research Society Symposium Proceedings* 185:239-251
- Fuchs, D R 1993 'Glass detects damage' in *SCHOTT information* 68:6-9
- García-Heras, M *et al* 2006 'Patination of historical stained windows lead comes from different European locations'. *Microchemical Journal*, Volume 83, Issue 2, 81-90
- Geotti-Bianchini, F *et al* 2005 'MicroIRRS and EPMA study of the weathering of potash-lime-silicate glasses'. *Rivista della Stazione Sperimentale dei Vetro*, 35, 49-61
- Gilberg, M 1996 'Protective glazing study'. U.S. National Park Service, Report Number 1996-06
- Gilberg, M *et al* 2002 'Analysing the impact of protective glazing on stained glass windows' *Studies in Conservation* 47:161-174
- Gläser, H J 'Calculation program for surface temperatures of window glazings and the appearance of condensation', available at: <http://www.glassfiles.com/articles/calculation-program-surface-temperatures-window-glazing-and-appearance-condensation.htm> (accessed 16/11/15)
- Godoi, R H M *et al* 2006 'The shielding effect of the protective glazing of historical stained glass windows from an atmospheric chemistry perspective: Case study Sainte Chapelle, Paris' *Atmospheric Environment* 40: 1255-1265
- Husband, T *et al* (eds.) 2010 *The Art of Collaboration: Stained Glass Conservation in the 21st Century*. Washington: Harvey Miller
- Ionescu, A *et al* 2012 'Long term damage to glass in Paris in a changing environment' *Science of the Total Environment* 431:151-156
- Klems, J H 2003 'Measured Winter Performance of Storm Windows' *ASHRAE Transactions* 109(2) Paper KC-03-12-1
- Kontozova-Deutsch, V. *et al* 2008 'Investigation of gaseous and particulate air pollutants at the Basilica Saint-Urbain in Troyes, related to the preservation of the medieval stained glass' *Microchimica Acta* 162:425-432
- Kontozova-Deutsch, V. *et al* 2011 'Urban air pollutants and their micro effects on medieval stained glass windows' *Microchemical Journal* 99:508-513
- Lombardo, T *et al* 2010 'Dose-response function for the soiling of silica-soda-lime glass due to dry deposition' *Science of the Total Environment* 408:976-984

- Luxford, N 2014 'Evaluation of light transmission effects of secondary glazing using high dynamic range photography', Tobit Curteis Associates
- Melchar, M and Schreiner, M 2004 'Statistical evaluation of potash-lime-silica glass weathering' *Analytical and Bioanalytical Chemistry* 379: 628-639
- Müller, W *et al* 2000 'Science in the service of restoration' Spooner, J, Seliger L (transl.) from Wolff, A (ed.), *Restaurierung und konservierung historischer glasmalereien*, Mainz: Verlag Philipp von Zabern 65-99. Available at: <http://www.cvma.ac.uk/conserv/mould.html>
- Newton, R G 1975 'Conservation of mediaeval windows (isothermal glazing)' in *Conservation in archaeology and the applied arts Preprints of the contributions to the Stockholm Congress, 2-6 June 1975*. London: IIC 111-114
- Newton, R G 1980 'A study of conditions in five ventilated double windows in cathedrals' in Brommelle, N S, Thomson, G, Smith, P (eds.) *Conservation within historic buildings Preprints of the contributions to the Vienna Congress, 7-13 September 1980*, London: IIC 89-92
- Oidtmann, S *et al* 2000 'Protective glazing' in Becker-Hounslow, S, Spooner, J, Strobl, S (transl.) from 'Schutzverglasungen' in A. Wolff (ed.), *Restaurierung und konservierung historischer glasmalereien*, Mainz: Verlag Philipp von Zabern 167-209. Available online at: <http://www.cvma.ac.uk/conserv/glazing.html> (accessed 25/4/2018)
- Patronis, C 2002 'The environmental performance of isothermal glazing systems'. MSc EDE dissertation, University College, London
- Rauch, I 2004 'The conservation and restoration of historical stained and painted glass: an introduction to the problems' in Spooner, J. (transl.) from 'Konservierung und Restaurierung historischer Glasmalereien: eine Einführung in die Problematik'. *Die Denkmalpflege*, 62:141-154. Available online at <http://www.cvma.ac.uk/conserv/rauch.html> (accessed 25/4/2018)
- Robinet, L *et al* 2006a 'Raman investigation of the structural changes during alteration of historic glasses by organic pollutants'. *Journal of Raman Spectroscopy* 37:1278-1286
- Robinet, L *et al* 2006b 'The use of Raman spectroscopy to predict the stability of historic glasses' *Journal of Raman Spectroscopy* 37: 789-797
- Römich, H 2004 'Evaluation of protective glazing systems' *e-Preservation Science* 1:1-8
- Schalm, O *et al* 2009 'Enamels in stained glass windows: preparation, chemical composition, microstructure and causes of deterioration'. *Spectrochimica Acta Part B*, 64, 812-820
- Simmons, C T and Mysak, L A 2010 'Transmissive properties of medieval and renaissance stained glass in European churches'. *Architectural Science Review* 53:251-274
- Slater, S 2014 'Thermal performance of protective glazing systems'. *Element Energy*
- Sparrow, E M and Azevedo, L F A 1985 'Vertical-channel natural convection spanning between the fully-developed limit and the single-plate boundary-layer limit'. *International Journal of Heat and Mass Transfer*, 28, 1847-1857
- Trumpler, S 1988 'Experience with protective glazings in Switzerland' in *Newsletter Technical Committee Corpus Vitrearum International* 41/42. Available online at: http://cvi.cvma-freiburg.de/documents/newsletter/CVMAnewsletter41_42.pdf (accessed 25/4/2018)
- Van der Snickt, G *et al* 2006 'Blue enamel on sixteenth- and seventeenth-century window glass: deterioration, microstructure, composition and preparation'. *Studies in Conservation*, 51, 212-222
- Verney-Carron, A *et al* 2012 'Predicting changes of glass optical properties in polluted atmospheric environment by a neural network model'. *Atmospheric Environment* 54:141-148

VIDRIO 2005 *Rivista della Stazione Sperimentale del Vetro* 35(3), for further information see:
<http://www.isac.cnr.it/~vidrio/index2.htm>

Walters, H V and Adams, P B 1975 'Effects of humidity on the weathering of glass'. *Journal of Non-Crystalline Solids* 19:183-199

Woisetschläger, G. et al 2000 'Weathering phenomena on naturally weathered potash-lime-silica-glass with medieval composition studied by secondary electron microscopy and energy dispersive microanalysis'. *Mikrochimica Acta* 135:121-130

Wolf, S *et al* 2013 'Protective glazing: the conflict between energy saving and conservation requirements', in Roemich, H., van Lookeren Campagne, K (eds) *Recent Advances in Glass Stained Glass and Ceramics Conservation*. Zwolle: Spa Uitgevers, 99-108

Useful weblinks

Corpus Vitrearum Medii Aevi
<http://www.cvma.ac.uk/resources/glossary.html>

Corpus Vitrearum Medii Aevi
<http://www.cvma.ac.uk/conserv/guidelines.html>

Corning Museum of Glass
<http://www.cmog.org/research/glass-dictionary>



Historic England Research and the Historic Environment

We are the public body that looks after England's historic environment. We champion historic places, helping people understand, value and care for them.

A good understanding of the historic environment is fundamental to ensuring people appreciate and enjoy their heritage and provides the essential first step towards its effective protection.

Historic England works to improve care, understanding and public enjoyment of the historic environment. We undertake and sponsor authoritative research. We develop new approaches to interpreting and protecting heritage and provide high quality expert advice and training.

We make the results of our work available through the Historic England Research Report Series, and through journal publications and monographs. Our online magazine Historic England Research which appears twice a year, aims to keep our partners within and outside Historic England up-to-date with our projects and activities.

A full list of Research Reports, with abstracts and information on how to obtain copies, may be found on www.HistoricEngland.org.uk/researchreports

Some of these reports are interim reports, making the results of specialist investigations available in advance of full publication. They are not usually subject to external refereeing, and their conclusions may sometimes have to be modified in the light of information not available at the time of the investigation.

Where no final project report is available, you should consult the author before citing these reports in any publication. Opinions expressed in these reports are those of the author(s) and are not necessarily those of Historic England.

The Research Report Series incorporates reports by the expert teams within the Investigation & Analysis Division of the Heritage Protection Department of Historic England, alongside contributions from other parts of the organisation. It replaces the former Centre for Archaeology Reports Series, the Archaeological Investigation Report Series, the Architectural Investigation Report Series, and the Research Department Report Series